

iR1600/iR2000

SERVICE MANUAL

REVISION 0

Canon

SEPT. 2001

FY8-13HJ-000

Application

This manual has been issued by Canon Inc. for qualified persons to learn technical theory, installation, maintenance, and repair of products. This manual covers all localities where the products are sold. For this reason, there may be information in this manual that does not apply to your locality.

Corrections

This manual may contain technical inaccuracies or typographical errors due to improvements or changes in products. When changes occur in applicable products or in the contents of this manual, Canon will release technical information as the need arises. In the event of major changes in the contents of this manual over a long or short period, Canon will issue a new edition of this manual.

The following paragraph does not apply to any countries where such provisions are inconsistent with local law.

Trademarks

The product names and company names used in this manual are the registered trademarks of the individual companies.

Copyright

This manual is copyrighted with all rights reserved. Under the copyright laws, this manual may not be copied, reproduced or translated into another language, in whole or in part, without the written consent of Canon Inc.

COPYRIGHT © 2001 CANON INC.

Printed in Japan











Imprimé au Japon

Caution

Use of this manual should be strictly supervised to avoid disclosure of confidential information.

1 Symbols Used

This documentation uses the following symbols to indicate special information:

Symbol	Description
	Indicates an item of a non-specific nature, possibly classified as Note, Caution, or Warning.
	Indicates an item requiring care to avoid electric shocks.
	Indicates an item requiring care to avoid combustion (fire).
	Indicates an item prohibiting disassembly to avoid electric shocks or problems.
	Indicates an item requiring disconnection of the power plug from the electric outlet.
 Memo	Indicates an item intended to provide notes assisting the understanding of the topic in question.
 REF.	Indicates an item of reference assisting the understanding of the topic in question.
	Provides a description of a service mode.
	Provides a description of the nature of an error indication.
	Refers to the Copier Basics Series for a better understanding of the contents.

2 Outline of the Manual

This Service Manual provides basic facts and figures needed to service the iR1600/iR2000. Of the machine's accessories, this manual covers the cassette unit and inner 2-way tray; for other accessories including the ADF, see its own Service Manual.

In this manual, the 1-Cassette Unit-F1, 2-Cassette Unit-G1 and 3-Cassette Unit-H1 are collectively called "cassette unit," and the Inner 2-Way Tray-B1 is referred to as the inner 2-way tray.

This Service Manual consists of the following chapters:



Chapter 1 Introduction:	features, specifications, operation, system construction, routine maintenance by the user, safety, reproduction processes
Chapter 2 Basic Operation:	basic operation, outline of electrical circuitry, basic sequence
Chapter 3 Image Reading/ Processing System:	principles of operation of the exposure system, principles of operation of the image processing system, timing of operation; disassembly/assembly and adjustment
Chapter 4 Laser Exposure System:	principles of operation of the image formation system, timing of operation; disassembly/assembly
Chapter 5 Image formation system:	standards, adjustments, troubleshooting tables
Chapter 6 Pickup/Feeding System:	principles of operation of the pickup/feeding system, timing of operation; disassembly/assembly and adjustment
Chapter 7 Fixing System:	principles of operation of the fixing system, timing of operation; disassembly/assembly and adjustment
Chapter 8 Externals and Auxiliary Control System:	principles of operation of the externals/auxiliary control system, timing of operation; disassembly/assembly and adjustment
Chapter 9 Cassette Unit:	principles of operation of the pickup system; disassembly/assembly and adjustments
Chapter 10 Inner 2-Way Tray:	principles of operation; disassembly/assembly and adjustment
Chapter 11 Installation:	site requirements and installation procedure
Chapter 12 Maintenance and Inspection:	table of periodically replaced parts, table of durables, scheduled servicing chart
Chapter 13 Troubleshooting:	maintenance and inspection, standards/adjustment, troubleshooting image faults/malfunctions; service mode, self diagnosis
Chapter 14 Version up:	version up
Appendix:	general timing chart, general circuit diagram

The descriptions are subject to change for product improvement, and major changes will be communicated in the form of Service Information bulletins.

All service persons are expected to go through the contents of this Service Manual and Service Information bulletins and have a good understanding of the machine, readying themselves to promptly respond to the needs of the field (i.e., identifying and correcting faults).

The descriptions in this Service Manual are based on the following rules:

1. In each chapter, the uses of the function in question and its relationship to electrical and mechanical systems are discussed and the timing of operation of its associated parts is explained by means of outlines and diagrams.

In the diagrams, the symbol  represents a mechanical path, while the symbol  with a name next to it indicates the flow of an electric signal.

The expression “turn on the power” means turning on the power switch, closing the front door, and closing the delivery door so that the machine will be supplied with power.

2. In circuit diagrams (digital), a signal whose level is High is expressed as being ‘1’, while a signal whose level is Low is expressed as being ‘0’; the level of voltage, however, varies from circuit to circuit.

The machine uses CPUs, whose internal mechanisms cannot be checked in the field, and, therefore, are not explained. In addition, the machine’s PCBs are not intended for repairs at the user’s and, therefore, are explained by means of block diagrams: two types are used, i.e., between sensors and inputs of PCBs equipped with a control or drive function and between outputs equipped with a control or drive function and loads; in addition, functional block diagrams are used at times.

Changes made to the machine for product improvement are communicated in the form of a Service Information bulletin as needed. All service persons are expected to go through all service documentation including the bulletins and be equipped to respond to the needs of the field (as by being able to identify possible causes of problems).

System Configuration

1. The machine may be configured as follows with its accessories (except the original/paper feed device and boards):

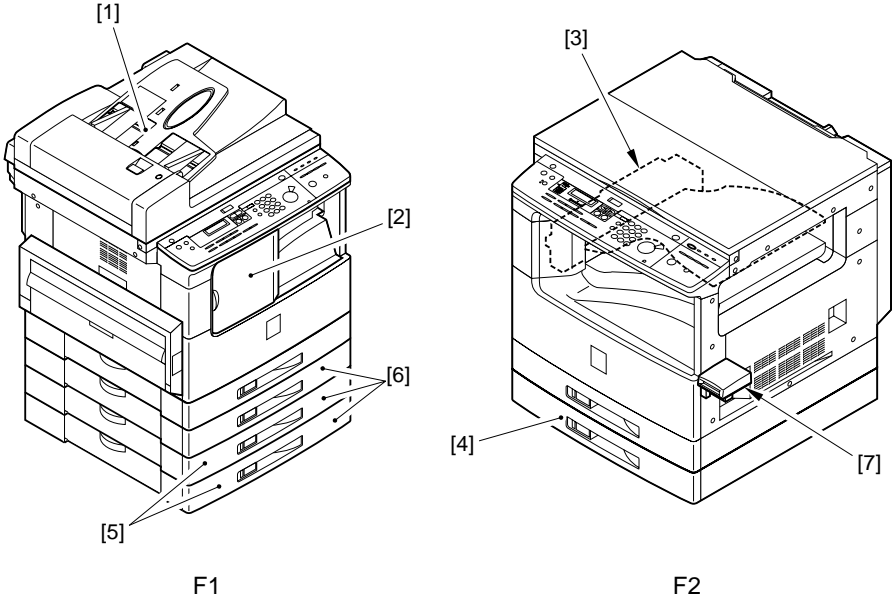

- [1] ADF-J1
- [2] Finisher-L1 (if PDL output, requires hard disk.)
- [3] Inner 2-Way Tray-B1
- [4] 1-Cassette Unit-F1 (iR1600 only)
- [5] 2-Cassette Unit-G1 (iR2000 only)
- [6] 3-Cassette Unit-H1 (iR1600 only)
- [7] Card Reader-E1

2. The machine may be configured with the following accessory boards:

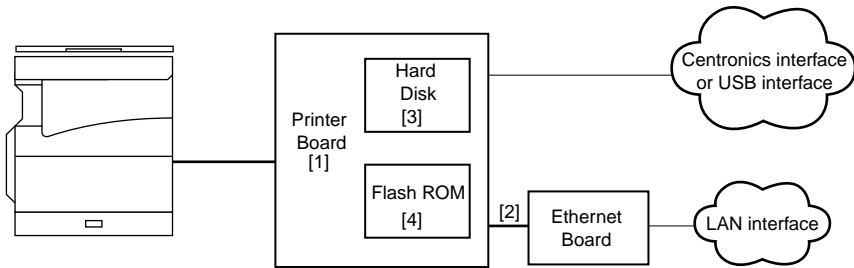

—— : Internal interface
- - - : External interface

F3

- [1] Printer Board-N1*
- [2] Ethernet Network Interface Adapter iN-E5*
- [3] Hard Disk HD-65
- [4] Flash ROM Module FR-65

* : standard if printer model

<Points to Note When Turning Off the Power Switch>

Be sure to turn off the power switch and disconnect the power plug before starting disassembly/assembly work; further, keep the following in mind:

1. If you turn off the main power switch while a printer function is in use, the data being processed can be lost. Check to be sure that the online LED in the control panel is OFF before operating the power switch.
2. Do not turn off the power switch while downloading is taking place; otherwise, the machine may fail to operate.
3. Remember that not all power will be removed in response to the opening of the front cover as long as the power switch remains ON.
4. Be sure to use SHUT DOWN MENU to shut down the printer if the Hard Disk HD-65 (accessory) has been installed.

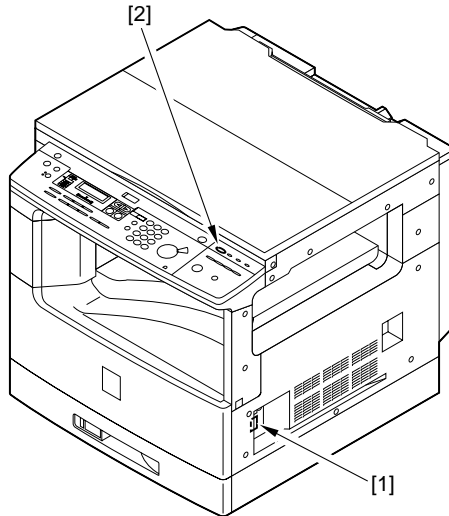

F4

- [1] Power switch
[2] Online LED

Contents

CHAPTER 1 INTRODUCTION

1 Features	1-1	4 Control Panel	1-18
1.1 Features	1-1	4.1 Control Panel	1-18
2 Specifications	1-1	4.2 Basic Operation	1-21
2.1 Copier	1-3	4.3 Extended Operation	1-21
2.1.1 Type	1-3	4.4 User Mode	1-22
2.1.2 System	1-3	5 Cleaning by the User	1-30
2.1.3 Functions	1-4	5.1 Cleaning by the User	1-30
2.1.4 Others	1-6	5.1.1 Cleaning the	
2.2 Cassette Unit	1-8	Fixing Roller	1-30
2.3 Inner 2-Way Tray	1-9	5.1.2 Cleaning the Copyboard Glass,	
3 Names of Parts	1-10	Reading Glass, and Copyboard	
3.1 External View	1-10	Cover White Plate	1-32
3.1.1 Copier	1-10	6 Safety and Warnings	1-33
3.1.2 Cassette Unit	1-12	6.1 Safety of Laser Light	1-33
3.1.3 Inner 2-Way Tray	1-13	6.2 CDRH Requirements	1-33
3.2 Cross Section	1-14	6.3 Handling the Laser Unit	1-34
3.2.1 Copier	1-14	6.4 Safety of the Toner	1-35
3.2.2 Cassette Unit	1-16	7 Reproduction Processes	1-36
3.2.3 Inner 2-Way Tray	1-17	7.1 Outline	1-36

CHAPTER 2 BASIC OPERATION

1 Basic Operation	2-1	1.3.3 Wiring Diagram of Electrical	
1.1 Functional Construction	2-1	Components (2/2)	2-8
1.2 Outline of Electrical Circuitry ..	2-2	1.4 Basic Sequence of Operation	2-9
1.2.1 Image Processor PCB	2-2	1.4.1 Outline	2-9
1.2.2 DC Controller PCB	2-3	1.4.2 Basic Sequence of Operation	
1.2.3 Power Supply PCB	2-5	(power-on)	2-10
1.2.4 Analog Processor PCB	2-5	1.4.3 Basic Sequence of Operation	
1.3 Inputs to and Outputs from Electri-		(printing)	2-11
cal Components	2-6	1.5 Controlling the Main Motor	
1.3.1 Wiring Diagram of the Major		(M101)	2-13
PCBs	2-6	1.5.1 Outline	2-13
1.3.2 Wiring Diagram of the Electri-			
cal Components (1/2)	2-7		

CHAPTER 3 IMAGE READING/PROCESSING SYSTEM

1 Outline of Operation	3-1	4.9 Edge Emphasis	3-17
1.1 Outline	3-1	4.10 Editing	3-17
2 Reader Drive System	3-2	4.11 Density Conversion (LUT, i.e., look-up table processing)	3-17
2.1 Outline	3-2	4.11.1 Density Adjustment (F-value conversion)	3-17
2.2 Controlling the Reader Motor... 3-3		4.11.2 Density Correction (g correction)	3-17
2.2.1 Moving the Carriage in Reverse After an Image Scan	3-3	4.12 Binary Processing	3-18
3 Detecting the Size of Originals	3-4	4.12.1 Error Diffusion	3-18
3.1 Outline	3-4	4.13 Image Memory Control	3-18
3.2 Detection by the Original Size Sensors	3-4	4.13.1 Compression/Expansion, Rotation, and Enlargement/ Reduction	3-18
3.3 Detecting the Size of Originals	3-6	4.13.2 SDRAM	3-18
3.4 Detection by the ADF	3-7	4.14 Output Image Processing	3-19
4 Image Processing	3-8	4.14.1 Smoothing	3-19
4.1 Outline	3-8	5 Disassembly and Assembly	3-20
4.2 Contact Sensor	3-9	5.1 Copyboard Glass	3-21
4.2.1 Outline of the Contact Sensor	3-9	5.1.1 Removing the Copyboard Glass	3-21
4.2.2 Construction of the Contact Sensor (CS)	3-10	5.1.2 After Replacing the Copyboard Glass	3-23
4.3 A/D Conversion	3-11	5.2 CS Unit	3-23
4.4 Shading Correction	3-11	5.2.1 Removing the CS Unit	3-23
4.4.1 Black Shading Correction	3-12	5.2.2 Points to Note When Mounting the CS Unit	3-26
4.4.2 White Shading Correction	3-12	5.2.3 After Replacing the CS Unit	3-28
4.5 Re-Ordering	3-12	5.2.4 Points to Note When Handling the CS Unit	3-29
4.6 ABC (auto background control)	3-13	5.3 Reader Motor	3-30
4.7 LED Intensity Adjustment	3-14	5.3.1 Removing the Reader Motor	3-30
4.8 Enlargement/Reduction	3-14	5.3.2 Points to Note When Mounting the Reader Motor	3-31
4.8.1 Enlargement/Reduction in Main Scanning Direction ..	3-14		
4.8.2 Changing the Reproduction Ratio in Sub Scanning Direction	3-16		

CHAPTER 4 LASER EXPOSURE SYSTEM

1 Outline of Operation	4-1	4 Controlling the Scanner Motor	4-8
1.1 Outline	4-1	4.1 Outline	4-8
1.2 Basic Sequence of Operation (laser exposure system)	4-3	4.2 Controlling the Scanner Motor	4-8
2 Generating the Horizontal Signal	4-4	4.3 Scanner Pre-Rotation	4-9
2.1 Outline	4-4	5 Disassembly and Assembly	4-10
2.2 Signals Used	4-4	5.1 Removing the Laser/ Scanner Unit	4-11
3 Laser Driver Circuit	4-6		
3.1 Laser Control	4-6		

CHAPTER 5 IMAGE FORMATION SYSTEM

1 Outline of Processes	5-1	3.4 Controlling the Voltage Level of the Developing DC Bias	5-7
1.2 Sequence of Operation (image formation system)	5-3	4 Controlling the Transfer Charging Roller Bias	5-8
2 Controlling the Primary Charging Roller Bias	5-4	4.1 Outline	5-8
2.1 Outline	5-4	4.2 Turning On and Off the Bias	5-9
2.2 Turning On and Off the Bias	5-5	4.2.1 Turning On and Off the Positive DC Bias	5-9
2.2.1 DC Bias	5-5	4.2.2 Turning On and Off the Negative DC Bias	5-9
2.2.2 AC Bias	5-5	4.3 Controlling the Bias to a Constant Current /Voltage Level	5-9
2.3 Bias Constant Voltage/ Constant Current Control	5-5	4.3.1 Controlling the DC Bias to a Constant Current Level	5-9
2.3.1 DC Bias Constant Voltage Control	5-5	4.3.2 Controlling the DC Bias to a Constant Level	5-9
2.3.2 AC Bias Constant Current Control	5-5	4.4 Correcting the Voltage Level (ATVC control)	5-10
3 Controlling the Developing Bias	5-6	4.5 Controlling the Output According to Operation Mode	5-10
3.1 Outline	5-6	4.5.1 Type of Mode	5-10
3.2 Turning On/Off the Bias	5-7	5 Detecting the Presence/Absence of a Cartridge and the Level of Toner	5-11
3.2.1 DC Bias	5-7	5.1 Outline	5-11
3.2.2 AC Bias	5-7	5.2 Sequence of Detection (level of toner)	5-12
3.3 Controlling the Bias to a Constant Voltage Level	5-7	6 Monitoring the Waste Toner Case ...	5-14
3.3.1 Controlling the Developing DC Bias to a Constant Level	5-7	6.1 Outline	5-14
3.3.2 Controlling the Developing AC Bias to a Constant Voltage Level	5-7		

6.2	Sequence of Operation	5-15	7.2	Developing Assembly	5-18
7	Disassembly and Assembly	5-16	7.2.1	Removing the Developing Assembly	5-18
7.1	Photosensitive Drum	5-17	7.3	Transfer Roller	5-20
7.1.1	Removing the Drum Unit	5-17	7.3.1	Removing the Transfer Roller	5-20
7.1.2	Cleaning the Photosensitive Drum	5-17			

CHAPTER 6 PICKUP/FEEDING SYSTEM

1	Outline	6-1	4.2.4	Jam History	6-17
1.1	Specifications and Constructions	6-1	5	Disassembly and Assembly	6-18
1.2	Arrangement of Major Rollers and Sensors	6-2	5.1	Cassette Pickup Assembly	6-19
2	Controlling the Pickup Assembly	6-3	5.1.1	Remove the Cassette Pickup Assembly	6-19
2.1	Controlling the Pickup from the Cassette	6-3	5.1.2	Removing the Cassette Pickup Roller	6-21
2.1.1	Outline	6-3	5.1.3	Removing the Feeding/ Separation Roller	6-22
2.1.2	Pickup form the Cassette ...	6-4	5.1.4	Removing the Cassette Pickup Solenoid	6-22
2.1.3	Pickup Retry	6-6	5.1.5	Removing the Paper Size Detecting Switch	6-22
2.1.4	Detecting the Size of Paper in the Cassette	6-7	5.1.6	Removing the Cassette Paper Sensor	6-23
2.2	Controlling the Pickup from the Multifeeder Tray	6-8	5.1.7	Removing the Retry Sensor	6-23
2.2.1	Outline	6-8	5.1.8	Removing the Pickup Motor (iR2000 only)	6-23
2.2.2	Pickup from the Multifeeder Tray	6-9	5.2	Multifeeder Tray Assembly	6-24
2.2.3	Multifeeder Retry Operation	6-11	5.2.1	Removing the Multifeeder Tray	6-24
2.2.4	Setting the Paper Size for the Multifeeder Tray (user mode)	6-11	5.2.2	Removing the Manual feed Pickup Roller	6-25
3	Controlling the Registration Roller	6-12	5.2.3	Removing the Separation Pad	6-26
3.1	Detecting the Leading Edge of Paper	6-12	5.2.4	Removing the Multifeeder Paper Sensor	6-26
4	Detecting Jams	6-13	5.2.5	Removing the Multifeeder Pickup Solenoid	6-27
4.1	Outline	6-13	5.3	Drive Assembly	6-27
4.2	Sequence of Jam Detection	6-14	5.3.1	Removing the Drive Assembly	6-27
4.2.1	Delay Jam	6-14			
4.2.2	Stationary Jams	6-16			
4.2.3	Cover Open Jam	6-17			

5.4 Registration Roller Assembly	6-31	5.4.2 Removing the Registration Paper Sensor	6-32
5.4.1 Removing the Registration Roller	6-31	5.4.3 Removing the Registration Clutch	6-33

CHAPTER 7 FIXING SYSTEM

1 Outline of Operation	7-1	2.3.3 Conditions for Error Detection	7-8
1.1 Outline	7-1	2.4 Protective Mechanism	7-10
2 Controlling the Fixing Temperature ..	7-3	3 Disassembly and Assembly	7-11
2.1 Outline	7-3	3.1 Removing the Fixing Assembly	7-12
2.2 Controlling the Temperature	7-4	3.2 Cleaning the Inside of the Fixing Assembly or Replacing Its Parts	7-15
2.2.1 Control at Time of Power-On	7-5	3.3 Removing the Delivery Sensor ..	7-15
2.2.2 Control According to the Type of Paper	7-6	3.4 Removing the Pressure Roller ..	7-16
2.2.3 Control at Time of Down Sequence	7-6	3.5 Removing the Fixing Roller/ Fixing Heater/Separation Claw	7-22
2.2.4 Control in ESS (energy save mode)	7-7	3.6 Mounting the Fixing Roller/ Fixing Heater/Separation Claw	7-24
2.3 Detecting an Error	7-8		
2.3.1 Outline	7-8		
2.3.2 Control in Response to an Error	7-8		

CHAPTER 8 EXTERNALS AND AUXILIARY CONTROL SYSTEM

1 Control Panel	8-1	3 Control at Time of Energy Save Mode	8-6
1.1 The machine's control panel has the following construction	8-1	3.1 Outline	8-6
2 Power supply	8-2	3.2 Control	8-6
2.1 Power Supply	8-2	3.3 Operation	8-8
2.1.1 Outline	8-2	4 Fan	8-9
2.1.2 Rated Outputs from the Power Supply PCB	8-4	4.1 Outline	8-9
2.2 Protective Mechanisms	8-5	4.2 Control	8-10
2.3 High-Voltage Power Supply Circuit	8-5	4.2.1 Controlling the Speed	8-10
		4.2.2 Error Detection	8-11
		4.2.3 Sequence of Operation (fan drive)	8-11

5 Back-Up Battery	8-12	6.1.1 Removing the Front Cover	8-20
5.1 Back-Up Mechanism	8-12	6.1.2 Removing the Control Panel Lower Cover	8-20
5.1.1 Outline	8-12	6.2 Control Panel	8-21
5.1.2 Lithium Battery (BAT1)....	8-13	6.2.1 Removing the Control Panel	8-21
5.2 Back-Up Data	8-15	6.3 Main Motor	8-22
5.2.1 Types of Data	8-15	6.3.1 Removing the Main Motor	8-22
5.2.2 Printing Out the Back-Up Data List	8-16	6.4 Fan	8-23
6 Disassembly and Assembly	8-17		
6.1 External Covers	8-18		

CHAPTER 9 CASSETTE UNIT

1 Outline	9-1	4.2 Cassette Pickup Assembly	9-12
1.1 Outline	9-1	4.2.1 Removing the Cassette Pickup Assembly	9-12
1.2 Specifications and Construction	9-1	4.2.2 Removing the Cassette Pickup Roller	9-12
1.3 Arrangement of Major Rollers and Sensors	9-2	4.2.3 Removing the Cassette Pickup Solenoid	9-12
2 Pickup Assembly	9-4	4.2.4 Removing the Paper Size Switch	9-12
2.1 Pickup Control System	9-4	4.2.5 Removing the Cassette Paper Sensor	9-12
2.2 Pickup Control	9-7	4.2.6 Removing the Re-Try Sensor	9-12
2.3 Cassette Pickup Operation	9-7	4.3 PCBs	9-13
2.4 Pickup Re-Try Operation	9-7	4.3.1 Removing the Cassette Unit Controller PCB	9-13
2.5 Cassette Paper Size Detection ..	9-7	4.4 Drive-Related Parts	9-13
3 Detecting Jams	9-8	4.4.1 Removing the Pickup Motor	9-13
3.1 Outline	9-8		
3.2 Sequence of Jam Detection	9-8		
3.1.1 Delay Jam	9-8		
3.1.2 Stationary Jam	9-8		
3.1.3 Jam History	9-8		
4 Disassembly and Assembly	9-9		
4.1 Removing the Cassette Unit ...	9-10		

CHAPTER 10 INNER 2-WAY TRAY

1 Specifications	10-1	3 Detecting Jams	10-4
1.1 System	10-1	3.1 Outline	10-4
1.2 Arrangement of Rollers and Sensors	10-2	3.2 Sequence of Jam Detection	10-4
2 Controlling Delivery Operation	10-3	3.2.1 Delay Jam	10-4
2.1 Controlling Delivery Operation	10-3	3.2.2 Stationary Jam	10-4
2.2 Selecting a Delivery Slot (user mode)	10-3	3.2.3 Jam History	10-4
		4 Disassembly and Assembly	10-5
		4.1 Removing the Inner 2-Way Unit	10-6

CHAPTER 11 INSTALLATION

1 Selecting the Site of Installation	11-1	2.10 Data Initialization through Service Operation	11-21
2 Unpacking and Installing the Machine	11-3	2.11 Setting the Date/Time (user mode)	11-22
2.1 Points to Note Before Starting the Work	11-3	2.12 Storing the Specifications Report	11-23
2.2 Installing the Machine	11-4	2.13 Checking the Printer Functions (if equipped with printer functions)	11-24
2.3 Unpacking and Removing the Fixing Members	11-5	3 Relocating the Machine	11-25
2.4 Removing the Dummy Drum	11-7	4 Installing the Card Readere-E1 (accessory)	11-26
2.5 Mounting the Drum Unit	11-9	4.1 Points to Note for Installation	11-26
2.6 Mounting the Toner Cartridge	11-11	4.2 Installation	11-27
2.7 Putting Paper in the Cassette	11-14	5 Installing the Image RAM (accessory)	11-31
2.8 Placing Paper in the Multifeeder Tray	11-18	5.1 Installation	11-31
2.9 Checking the Copy Images ...	11-20		

CHAPTER 12 MAINTENANCE AND INSPECTION

1	Periodically Replaced Parts	12-1	3.1	Basic Service Work	12-3
1.1	Copier	12-1	4	Cleaning During a Visit	12-4
1.2	Cassette Unit	12-1	5	Points to Note When Storing/Handling the Drum Unit	12-7
1.3	Inner 2-Way Tray	12-1	5.1	Outline	12-7
2	Guide to Durables	12-2	5.2	Storage and Handling After Remov- ing the Packaging Seal	12-7
2.1	Checking the Timing of Replace- ment	12-2	5.2.1	Storage After Removing the Packaging Seal	12-7
2.2	Copier	12-2	5.2.2	Points to Note When Handling the Drum Unit	12-8
2.3	Cassette Unit	12-2			
2.4	Inner 2-Way Tray	12-2			
3	Basic Service Work	12-3			

CHAPTER 13 TROUBLESHOOTING

1	Image Adjustment Basic Procedure	13-1	2.3.5	When Replacing the DC Controller PCB	13-12
1.1	Image Adjustment Basic Procedure	13-1	2.3.6	When Replacing the Analog Processor PCB	13-12
2	Standards and Adjustments	13-3	2.4	Checking the Sensors	13-13
2.1	Image Adjustments	13-3	2.4.1	Checking the Sensors	13-13
2.1.1	Standards for Image Position	13-3	3	Troubleshooting Image/Operation Faults	13-16
2.1.2	Adjusting the Image Position	13-4	3.1	Making Initial Checks on Image Faults	13-16
2.1.3	Adjusting the Leading Edge Margin for the Printer Unit (if equipped printer functions)	13-5	3.1.1	Site of Installation	13-16
2.1.4	Adjusting the Image Position for Copying	13-7	3.1.2	Checking the Originals ...	13-16
2.2	Fixing System	13-9	3.1.3	Copyboard Cover and Copyboard Glass (standard white plate)	13-16
2.2.1	Checking the Fixing Roller Pressure (nip)	13-9	3.1.4	Checking the Transfer Charg- ing Roller/Static Eliminator	13-17
2.3	Electrical Parts	13-10	3.1.5	Checking the Drum Unit	13-17
2.3.1	When Replacing the Major Parts	13-10	3.1.6	Checking the Paper	13-17
2.3.2	Gain Auto Adjustment	13-10	3.1.7	Image Adjustment Basic Procedure	13-17
2.3.3	When Replacing the Contact Sensor	13-10	3.1.8	Others	13-17
2.3.4	When Replacing the Image Processor PCB	13-11	3.2	Image Fault Samples	13-20
			3.3	Troubleshooting Image Faults	13-21

3.3.1 The copy is too light.
(halftone only) 13-21

3.3.2 The copy is too light.
(both halftone and solid black)
..... 13-21

3.3.3 The copy is too light.
(entire copy, appreciably)
..... 13-21

3.3.4 The copy has uneven density.
(darker along front) 13-24

3.3.5 The copy has uneven density.
(lighter along front) 13-24

3.3.6 The copy is foggy.
(entire copy) 13-25

3.3.7 The copy is foggy.
(feeding direction). 13-26

3.3.8 The copy has black lines.
(feeding direction, fuzzy, thick)
..... 13-26

3.3.9 The copy has black lines.
(feeding direction, fine) .. 13-26

3.3.10 The copy has white strips.
(feeding direction) 13-27

3.3.11 The copy has white lines.
(feeding direction) 13-27

3.3.12 The output has white strips.
(cross-feeding direction)
..... 13-28

3.3.13 The back of the copy is soiled.
..... 13-29

3.3.14 The copy has a poor fixing.
..... 13-30

3.3.15 The copy has displaced
registration. (leading edge
extremely excessive margin).
..... 13-31

3.3.16 The copy has displaced
registration. (leading edge,
excessive margin) 13-31

3.3.17 The copy has displaced
registration. (leading edge,
no margin) 13-31

3.3.18 The copy has blurred
images. 13-32

3.3.19 The copy is foggy. (cross-feed-
ing direction) 13-33

3.3.20 The copy has poor sharpness.
..... 13-34

3.3.21 The copy is blank. 13-35

3.3.22 The copy is solid black. .. 13-36

3.4 Troubleshooting Malfunctions
..... 13-37

3.4.1 AC power is absent. 13-37

3.4.2 DC power is absent. 13-38

3.4.3 Pickup operation fails.
(cassette) 13-39

3.4.4 Pickup operation fails.
(multifeeder tray) 13-40

3.4.5 Pickup operation fails. (cas-
sette unit) 13-41

3.4.6 The vertical path roller fails to
rotate. 13-42

3.4.7 The registration roller fails to
rotate. 13-42

3.4.8 The contact sensor fails to go
ON. 13-43

3.4.9 The speaker fails to operate.
..... 13-43

3.4.10 The 'Add Toner' message fails
to go OFF. 13-44

3.4.11 The 'Add Paper' message
fails to go OFF. (machine
and cassette unit) 13-45

3.4.12 The 'Add Paper' message fails
to go OFF. (multifeeder tray)
..... 13-46

3.4.13 The 'Jam' message fails to
go OFF. 13-46

3.4.14 The 'Waste Toner Full'
message does not go OFF.
..... 13-47

3.4.15 The 'Controller Card Set'
message does not go ON.
..... 13-47

3.4.16 The 'Control Card Set'
message does not go OFF.
..... 13-47

3.5 Troubleshooting Feeding Faults
..... 13-48

3.5.1	Outline	13-48	5.4.2	Setting Numeric Parameters (#3 NUMERIC Param.) ..	13-79
3.5.2	Pickup Assembly	13-49	5.4.3	Selecting the Country/Region of Installation (#5 TYPE)	13-82
3.5.3	Transfer/Feeding Assembly	13-50	5.4.4	Setting Original Read Func- tions (#6 SCANNER)	13-83
3.5.4	Fixing/Delivery Assembly	13-51	5.4.5	Setting the Printer Parameters (#7 PRINTER)	13-86
3.5.5	Feeding Fault (double feeding)	13-52	5.4.6	PDL (#8 PDL)	13-86
3.5.6	Feeding Faults (wrinkling)	13-53	5.4.7	Counters (#9 COUNTER)	13-87
4	Arrangement and Functions of Electrical Parts	13-54	5.4.8	Generating a Report (#10 REPORT)	13-90
4.1	Outline	13-54	5.4.9	Downloading (#11 DOWNLOAD)	13-91
4.1.1	Outline	13-54	5.4.10	Clear (#12 CLEAR)	13-92
4.1.2	Checking the Sensors	13-54	5.4.11	ROM Indication (#13 ROM)	13-93
4.2	Clutches, Solenoids, Motors, and Fans	13-55	5.4.12	Resetting the CS Unit Position (#14 CS SET)	13-93
4.3	Sensors	13-56	5.5	Test Mode (TEST MODE)	13-94
4.4	PCBs	13-57	5.5.1	Outline	13-94
4.5	Switches, Others	13-59	5.5.2	Test Mode Menu	13-95
4.6	Cassette Unit	13-61	5.5.3	D-RAM Test (1: D-RAM)	13-98
4.7	Inner 2-Way Tray	13-63	5.5.4	CCD Test (2: CCD TEST)	13-100
4.8	Variable Resistors (VR), Light-Emitting Diodes (LED), and Check Pins	13-64	5.5.5	PRINT Test (3: PRINT)	13-101
4.8.1	Image Processor PCB	13-65	5.5.7	Faculty Test (6: FACULTY TEST)	13-102
4.8.2	DC Controller PCB	13-66	5.5.8	Book Read Test (8: BOOK TEST)	13-108
4.8.3	Power Supply PCB	13-67	5.6	Report	13-109
4.8.4	Analog Processor PCB	13-68	5.6.1	User report	13-109
4.8.5	1-Cassette Unit Controller PCB	13-69	5.6.2	Service Report	13-110
4.8.6	2/3-Cassette Unit Controller PCB	13-69	6	Self Diagnosis	13-117
5	Service Mode	13-70	6.1	Outline	13-117
5.1	Outline	13-70	6.2	Error Codes	13-118
5.2	Using the Mode	13-72	6.2.1	Error Codes Used for the Machine	13-118
5.3	Service Mode Menus	13-73	6.2.2	Finisher Error Codes	13-123
5.4	Setting the parameters	13-77			
5.4.1	Registering the Bit Switch (#1 SSSW)	13-77			

CHAPTER 14 VERSION UP

1 Upgrading	14-1	2.3 Installing the Firmware	14-7
1.1 Outline	14-1	2.4 Downloading the System Software	14-10
2 Upgrading by Downloading	14-3	2.5 Downloading for the Finisher-L1	14-17
2.1 Before Starting the Work	14-3	2.5.1 Outline	14-17
2.2 Installing the USB Driver (only if Windows 98 or Windows 98SE)	14-4	2.5.2 Downloading	14-18

APPENDIX

A General Timing Charts	A-1	E Inner 2-way tray	A-7
B General Circuit Diagram	A-3	F Special Tools	A-9
C 1-cassette unit	A-5	G Solvents and Oils	A-11
D 2/3-cassette unit	A-6		

CHAPTER 1

INTRODUCTION

1 Features

1.1 Features

1. High-Speed, High Image Quality

Copying speed	16 copies/min (iR1600 ; 1-to-N, from cassette)
	20 copies/min (iR2000 ; 1-to-No: from cassette)
Reading resolution	: 600 dpi x 600 dpi
Printing resolution	
	Copying : 1,200 (equivalent) x 600 dpi
	PDL output : 2,400 (equivalent) x 600 dpi

2. Large Paper Source

With the addition of accessories, as many as 1,100 sheets (80 g/m²) may be accommodated.

Multifeeder : 100 sheets (A4R, A4, B5, B5R, A5, A5R; 80 g/m²)

- iR1600 Cassette

Cassette 1 : 250 sheets

1-cassette unit (accessory) : 250 sheets

3-cassette unit (accessory) : 250 sheets x 3

- iR2000 Cassette

Cassette 1 : 250 sheets

Cassette 2 : 250 sheets

2-cassette unit (accessory) : 250 sheets x 2

3. Mixed Paper Sizes (of same configuration)

Installation of an ADF will enable mixing of different paper sizes (of the same configuration).

4. Networking

Mounting of a printer board and network interface board will enable the use of the machine as a network printer in an Ethernet environment.

5. Hard Disk

Installation of a hard disk (accessory) will enable storage of image data on the hard disk. Since the images will be read from the hard disk, multiple sets of copies may be obtained faster (RIP-once function).

6. Selection of a Delivery Tray

Installation of an inner 2-way tray (accessory) will enable the selection of trays separately for copier and printer output (in user mode).

7. Auto Start/Interrupt Copying

The existing models retains no more than one job. The machine, however, keeps jobs on queue, thus enabling auto-start/interrupt copying.

2 Specifications

2.1 Copier

2.1.1 Type

Item	Description
Body	Desktop
Copyboard	Fixed
Light source	LED
Lens	Rod lens array
Photosensitive medium	OPC (30-mm dia.)

T01-201-01

2.1.2 System

Item	Description
Copying	Indirect photoelectric reproduction
Charging	Roller charging
Exposure	Semiconductor laser
Copy density adjustment	Auto or manual
Development	Dry, 1-component toner projection
Pickup	Cassette
	Manual feed tray
Transfer	Roller charging
Separation	Curvature + static (static eliminator)
Cleaning	Rubber blade
Fixing	Heat roller (800 W for 120/230V)

T01-201-02

2.1.3 Functions

Item	Description
Original type	Sheet, book, 3-D (2 kg max.)
Maximum original size	A3/279.4 x 431.8mm (11" x 17")
Reproduction ratio	Direct (1:1)
4R4E	Reduce I (1:0.500), Reduce II (1:0.707) Reduce III (1:0.816), Reduce IV (1:0.865) Enlarge I (1:1.154), Enlarge II (1:1.224), Enlarge III (1:1.414) Enlarge IV (1:2.000)
4R3E	Reduce I (1:0.500), Reduce II (1:0.647), Reduce III (1:0.733) Reduce IV (1:0.786) Enlarge I (1:1.214), Enlarge II (1:1.294), Enlarge III (1:2.000)
4R2E	Reduce I (1:0.500), Reduce II (1:0.707) Enlarge I (1:1.414), Enlarge II (1:2.000) Zoom (1:0.500 to 2.00; 50% to 200%; 1%-increment)
Wait time	30 sec or less from power-on (at 20°C room temperature)
First copy time	Less than 8.2 sec (from copier cassette; Direct, A4/LTR, non-AE)
Continuous copying	99 copies max.
Copy size	
Cassette	
	AB : A3 max. A5 (vertical) min.
	Inch : 11x17 (279.4 x 431.8 mm) max. STMT (vertical) min.
Multifeeder pickup	
	AB : A3 max. Postcard min.
	Inch : 11x17 (279.4 x 431.8 mm) max. STMT (vertical) min.

T01-201-03

Item	Description
Paper type	
Cassette	Plain paper (60 to 90 g/m ²), recycled paper (60 to 90 g/m ²), colored paper, label sheet
Multifeeder	Plain paper (60 to 90 g/m ²), thick paper (90 to 128 g/m ²), recycled paper (64 to 90 g/m ²), colored paper, transparency, postcard, double-postcard, envelope
Multifeeder	10 mm in height
Tray AB:	Plain paper, recycled paper, colored paper 100 sheets if A4R, A4, B5, B5R, A5, A5R (80 g/m ²) 50 sheets if A3, B4 (80 g/m ²) 50 sheets if transparency, thick paper (90 to 128 g/m ²) 10 sheets if envelope
Inch:	Plain paper, recycled paper, colored paper 100 sheets if LTR, LTRR, STMT, STMTR (80 g/m ²) 50 sheets if transparency, thick paper (90 to 128 g/m ²) 10 sheets if envelope 50 sheets if 11x17 (279.4x431.8 mm), LGL
Cassette	25 mm in depth (250 sheets max. of 80 g/m ²)
Delivery	Face-down (250 sheets max. of 80 g/m ²)
Non-image width	
Leading edge	3.0±2mm
Trailing edge	3.0±2mm
Left/right	3.0±2mm
Auto clear	Yes (2 min standard; may be changed between 0 and 9 min in 1-min increment)
Energy saver	Yes (15 min standard; may be changed between 3 and 30 min in 1-min increment)
Accessory	Cassette unit Finisher ADF Inner 2-way tray Card reader Hard disk Expansion RAM Flash ROM Network interface board *1 PCL printer board *1

*1 : Standard if printer model.

T01-210-04

2.1.4 Others

Item	Description	
Operating environment		
Temperature range	15 to 30°C; 59 to 86°F	
Humidity range	10% to 80%	
Atmospheric pressure range	810.6 to 1013.3 hPa (0.8 to 1.0 atm)	
Power supply	120V (60Hz), 230V (50Hz)	
Serial number	iR1600 : UHRxxxxx	iR2000 : UHSxxxxx
	UJJxxxxx	UJKxxxxx
	SDMxxxxx	SDPxxxxx
	SEDxxxxx	SEExxxxx
	TDWxxxxx	TDYxxxxx
	TENxxxxx	TEPxxxxx
	QSKxxxxx	QSMxxxxx
	RSMxxxxx	RSSxxxxx
	QENxxxxx	QEQxxxxx
	QFBxxxxx	QFCxxxxx
	QSLxxxxx	QSNxxxxx
	RSNxxxxx	REVxxxxx
	RENxxxxx	REPxxxxx
	RFJxxxxx	RFKxxxxx
	RSPxxxxx	RSTxxxxx
	RSQxxxxx	RSTxxxxx
Power consumption		
Maximum	940W	
Standby	30W (reference) *1	
Continuous copying	900W (reference) *1	
Energy saver	High	20W (reference) *1
	Low	4.8W (reference) *1
Noise		
Copying	66 dB or less	
Standby	40 dB or less	
Dimensions	iR 1600 615 (W) x 631 (D) x 560 (H) mm/24.0 (W) x 24.8 (D) x 22.0 (H) in.	
	iR 2000 615 (W) x 631 (D) x 645 (H) mm/24.0 (W) x 24.8 (D) x 25.1 (H) in.	
Weight	iR 1600 38.0kg/83.8lb iR 2000 43.4kg/95.7lb	
Consumables		
Paper	Keep wrapped to avoid humidity.	
Toner	Avoid direct sunshine, and keep at 40°C (104°F) 85% or less.	

*1 : In copyboard cover model; for rated power supply voltage in the absence of printer board.

T01-210-05

Reproduction ratio	Size	Paper size	Copies/min (1-to-N)	
			iR1600	iR2000
Direct	A3 (297 x 420mm)	A3	9	9
	A4 (297 x 420mm)	A4	16	20
	B4 (297 x 420mm)	B4	10	10
	B5 (297 x 420mm)	B5	16	20
	A4R (297 x 420mm)	A4R	12	15
	B5R (297 x 420mm)	B5R	13	16
	A5 (297 x 420mm)	A5	16	20

Auto paper select ON, Auto density adjustment ON, Non-sort, Pickup from cassette

T01-201-06

The above specifications are subject to change for product improvement.

Reproduction ratio	Size	Paper size	Copies/min (1-to-N)	
			iR1600	iR2000
Direct	279.4 x 431.8mm	279.4 x 431.8mm	9	9
	(11" x 17")	(11" x 17")		
	LTR	LTR	16	20
	LGL	LGL	10	10
	LTRR	LTRR	12	16
	STMT	STMT	16	20

Auto paper select ON, Auto density adjustment ON, Non-sort, Pickup from cassette

T01-201-07

The above specifications are subject to change for product improvement.

2.2 Cassette Unit

Item	Description
Pickup	Claw-less (retard) method
Paper type	Same as host.
Cassette	25 mm deep (250 sheets of 80 g/m ² paper max.)
Serial Number	1-cassette type : XGQxxxxx 2-cassette type : XGRxxxxx 3-cassette type : XGSxxxxx
Dimensions	
1-cassette type	560 (W) x 564.3 (D) x 90.8 (H) mm 22.0 (W) x 22.0 (D) x 3.54 (H) in.
2-cassette type	560 (W) x 564.3 (D) x 175.8 (H) mm 22.0 (W) x 22.0 (D) x 6.79 (H) in.
3-cassette type	560 (W) x 564.3 (D) x 260.8 (H) mm 22.0 (W) x 22.0 (D) x 10.2 (H) in.
Weight	
1-cassette type	6.3 kg/13.9 lb (approx.; including cassette)
2-cassette type	12.7 kg/28.0 lb (approx.; including cassette)
3-cassette type	19.1 kg/42.1 lb (approx.; including cassette)
Power supply	DC power from host
Operating environment	Same as host
Temperature range	
Humidity range	
Atmospheric pressure	

T01-202-01

The above specifications are subject to change for product improvement.

2.3 Inner 2-Way Tray

Item	Specifications
Number of bins	2 bins in total 1 bin (No. 2 delivery slot) Internal delivery tray of host (No. 1 delivery slot)
Stacking	Face-down
Type of paper in stack	Plain paper, recycled paper, colored paper (from 64g/m ² to 90 g/m ²)
Size of paper in stack	A3/279.4 x 431.8mm (11 x 17) to A5/STMT
Height of stack	100 sheets (A4, B5, LTR) 50 sheets (A3, B4, A4R, B5R, 11x17, LGL, LTRR, STMT) 20 sheet (A5R, STMTR)
Dimensions	149 (W) x 420 (D) x 254 (H) mm 5.9 (W) x 16.5 (D) x 9.8 (H) in
Weight	approx. 3.5kg/7.7lb
Power supply	DC 24V/5V from host

T01-203-01

3 Names of Parts

3.1 External View

3.1.1 Copier

- iR1600

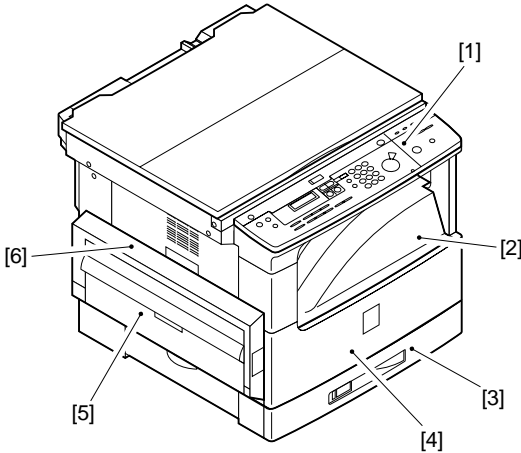

- [1] Control panel
- [2] Delivery tray
- [3] Cassette
- [4] Front cover
- [5] Manual feed tray
- [6] Left cover

- iR2000

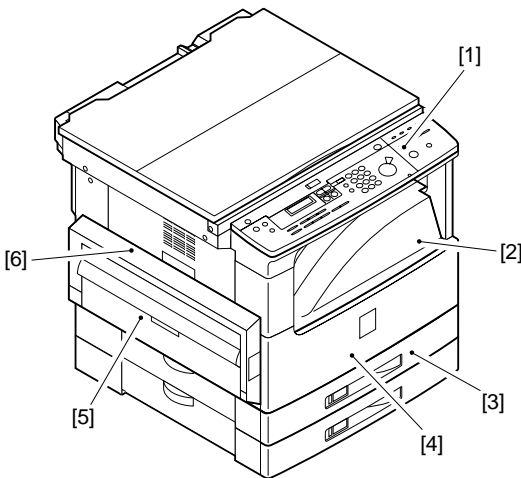

F01-301-01

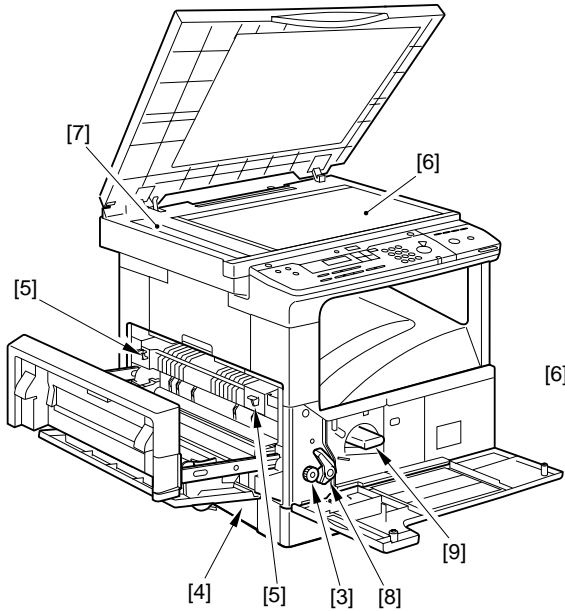
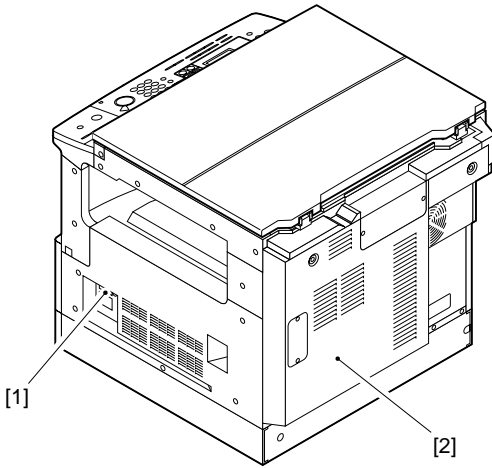

- [1] Power switch
- [2] Rear cover
- [3] Paper feed knob
- [4] Left lower cover
- [5] Pressure release lever
- [6] Copyboard glass
- [7] Reading glass
- [8] Developing assembly locking lever
- [9] Toner cartridge

F01-301-02

3.1.2 Cassette Unit

- 1-Cassette Type

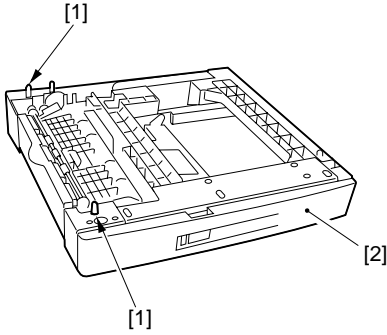

- [1] Positioning pin
- [2] Cassette

- 2-Cassette Type

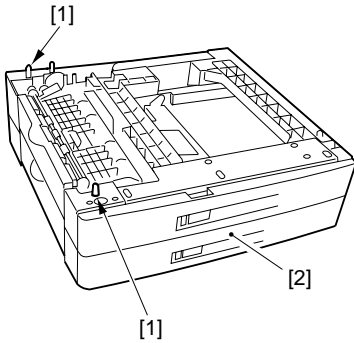

- 3-Cassette Type

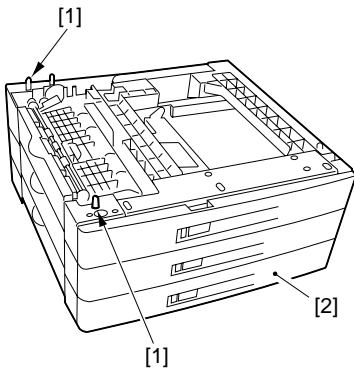

F01-301-03

3.1.3 Inner 2-Way Tray

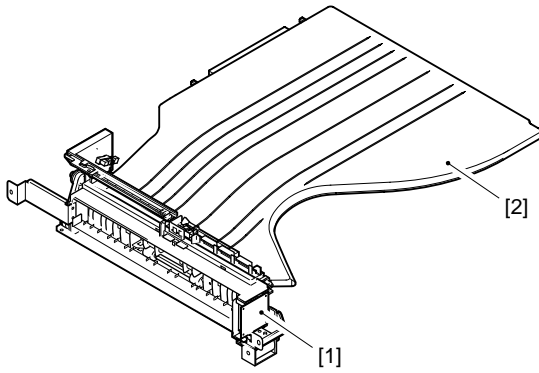

F01-301-04

- [1] Inner 2-way unit
- [2] No. 2 delivery tray

3.2 Cross Section

3.2.1 Copier

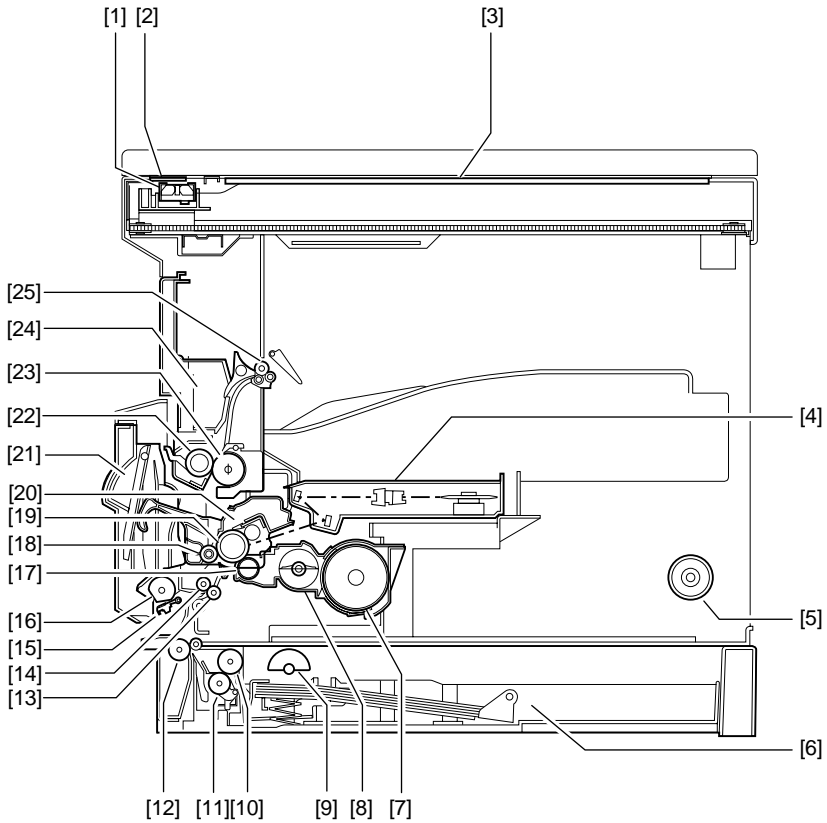

F01-302-01

- | | | | |
|------|--------------------------|------|----------------------------|
| [1] | CS unit | [14] | Registration roller |
| [2] | ADF reading glass | [15] | Manual feed separation pad |
| [3] | Copyboard glass | [16] | Manual feed pickup roller |
| [4] | Laser scanner unit | [17] | Developing cylinder |
| [5] | Speaker | [18] | Transfer charging roller |
| [6] | Cassette | [19] | Photosensitive drum |
| [7] | Toner cartridge | [20] | Drum unit |
| [8] | Developing assembly | [21] | Multifeeder tray |
| [9] | Pick roller | [22] | Fixing pressure roller |
| [10] | Feeding roller | [23] | Fixing roller |
| [11] | Separation roller | [24] | Fixing assembly |
| [12] | Vertical path roller | [25] | Delivery roller |
| [13] | Registration roller roll | | |

3.2.2 Cassette Unit

- 1-Cassette Type

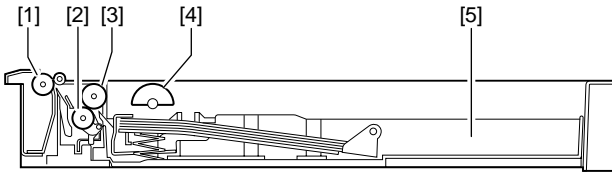

- 2-Cassette Type

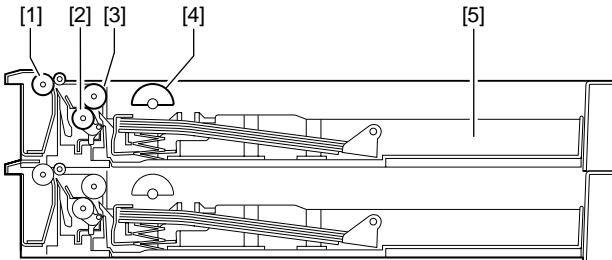

- 3-Cassette Type

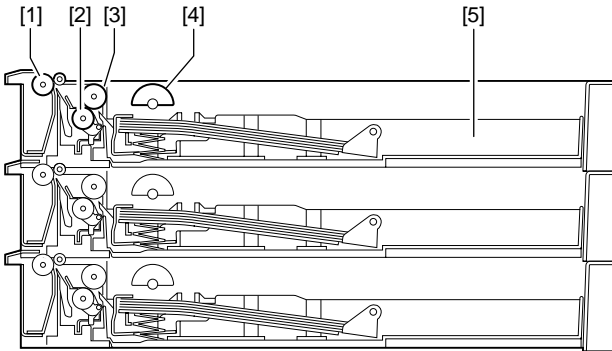

F01-302-02

- [1] Vertical path roller
- [2] Separation roller
- [3] Feeding roller
- [4] Pickup roller
- [5] Cassette

3.2.3 Inner 2-Way Tray

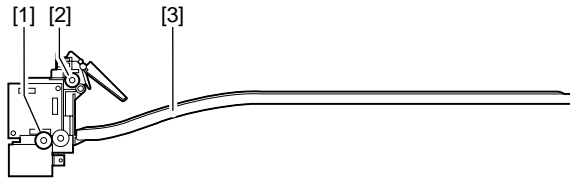

F01-302-03

- [1] Vertical path roller
- [2] Delivery roller
- [3] No. 2 delivery tray

4 Control Panel

4.1 Control Panel

The machine is equipped with one power switch, and the machine is supplied with power when the switch is turned on.

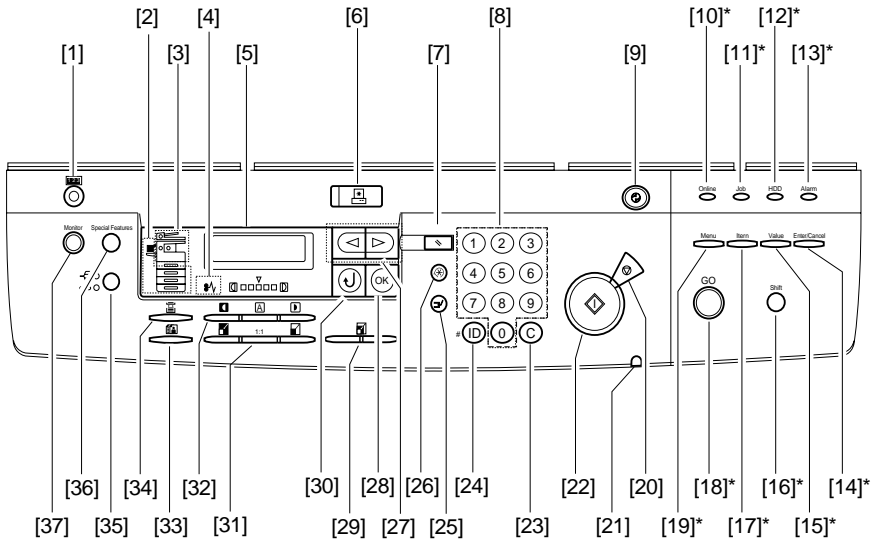

* Enabled only if the machine is equipped with a printer function.

F01-401-01

No.	Key/LED name	Description
[1]	Counter key	Press it to indicate the number of prints to make.
[2]	Paper Select indicator	Press it to indicate the selected cassette or stack bypass.
[3]	Jam Location indicator	Press it to indicate the location of a paper jam.
[4]	Jam indicator	Check it to see if a paper jam has occurred.
[5]	LCD display	Use it to bring up various settings screens.
[6]	System key and indicator	Press it to switch over printer functions; it remains ON when a printer function is in use.
[7]	Reset key	Press it to return the copying mode to default settings.
[8]	Numeric keypad	Use it to set how many copies to make.
[9]	Energy Saver key	Use it to end energy save mode.
[10]	On Line indicator*	Check it to see if the machine is in on-line state; it flashes while printing takes place.
[11]	Job indicator*	Check it to see if data reception is under way.
[12]	HDD indicator*	Check it to see if a hard disk is installed; it flashes while the hard disk is being accessed.
[13]	Alarm indicator*	Check it to see if an error has occurred.
[14]	Enter/Cancel key*	Press it to store/set a selected item.
[15]	Value key*	With an item name displayed, press the Value key to step through the item's values. Press Shift and Value keys to step through the values in reverse order. Some items have a large range of numbers from which to choose a value.
[16]	Shift key*	Press this key to scroll through menu or settings items in reverse order.
[17]	Item key*	With a menu name displayed, press the Item key to scroll through all the items on the menu and return to the first item. To scroll back through the items in the opposite direction, press the Shift and Item keys.
[18]	Go key*	Takes the printer off-line and brings it back on line. When the On Line indicator is on, the printer is ready to receive data and print. When the On Line Indicator is off, the printer is off-line, and you can use the other keys on the printer control panel to view and change settings.
[19]	Menu key*	With the printer off-line, press the Menu key to scroll through the menu names and return to the first menu name. To scroll back through the menu names in the opposite direction, press the Shift and Menu keys.
[20]	Stop key	Press it to stop copying operation.
[21]	Main Power indicator	Check it to see if the machine is ON.
[22]	Start key	Press it to start copying operation.
[23]	Clear key	Press it to clear registration/setting contents.
[24]	ID/#key	Press it when making settings in ID mode.
[25]	Interrupt key	Use it to select/cancel interrupt mode.

- | | |
|--------------------------------|--|
| [26] Additional Function key | Use it to bring up the Additional Functions (user mode) Settings screen. |
| [27] Cursor key | Use it to select an item when using menu settings. |
| [28] OK key | Use it to set a mode or function. |
| [29] Zoom key | Use it to make zoom settings. |
| [30] Back key | Use it to return to the previous screen when making menu settings. |
| [31] Reduce/Direct/Enlarge key | Use it to set Reduce, Direct, or Enlarge copy settings. |
| [32] Light/AE/Dark key | Use the AE key to register/set automatic exposure settings.
Use the Light/Dark key to manually adjust the copy density. |
| [33] Image Quality key | Use it to select a level of image quality from text, text/photo, and photo modes. |
| [34] Paper Select key | Use it to select a cassette or stack bypass. |
| [35] Finisher key | Use it to set a finisher function (collation, stapler). |
| [36] Special Features key | Use it to set a special copying feature (page separation, frame erasing, binding margin, reduced page composition). |
| [37] Monitor key | Use it to check the state of a copy job. |

* Enabled only if the machine is equipped with a printer function.

4.2 Basic Operation

Operate the machine as follows when using its basic functions:

Key to use	Description
Zoom key	Use it to select a default ratio or a zoom ratio (between 50% and 200%).
Paper Select key	Use it to select a cassette as a source of paper.
Image Quality key	Use it to select a level of image quality (text, text/photo, photo).
Light/AE/Dark key	Use it to select a reading density (auto, F1 through F9).

T01-402-01

4.3 Extended Operation

Press the Special Features key in the control panel to make use of the following functions:

Items	Description
2PG SET SETTING	Use it to select page separation in book mode (to copy left and right pages of spread book); specify open on left or right and original size.
MARGIN SETTING	Use it to create a binding margin on paper. Specify the location of margin (left, right, top, bottom) and the margin width (1 to 20 mm).
FRAME ERASE SETTING	Use it to specify the location of frame erasing.
DOC. FRAME ERASE	Use it to select frame erasing of the original.
BOOK FRAME ERASE	Use it to delete images of the sides and middle binding width of the original (e.g., book).
HOLE PUNCHERASE	Use it to delete the image, if any, of holes in the original (on the left side) so that the copies will not show them.
2 ON 1 SETTING	Use it to enter an original size and paper size; then to select 2-on-1 or 4-on-1 copying mode.

T01-403-01

4.4 User Mode

A press on the Additional Functions key in the control panel will bring up the User Mode settings screen.

The user mode is structure ed as follows:

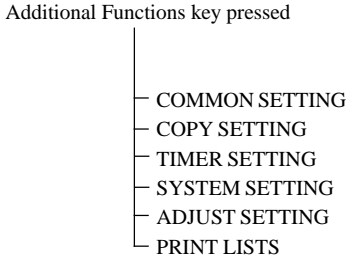

For sub items, see the pages that follow.

COMMON SETTINGS

*, The notation within brackets <> indicates factory settings.

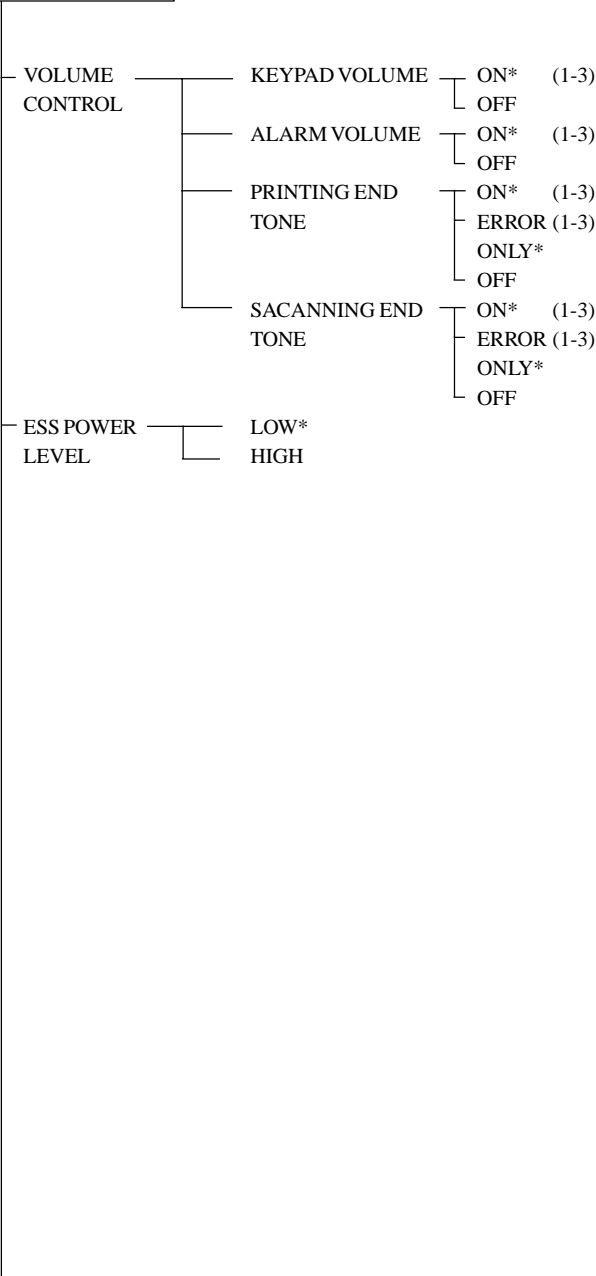

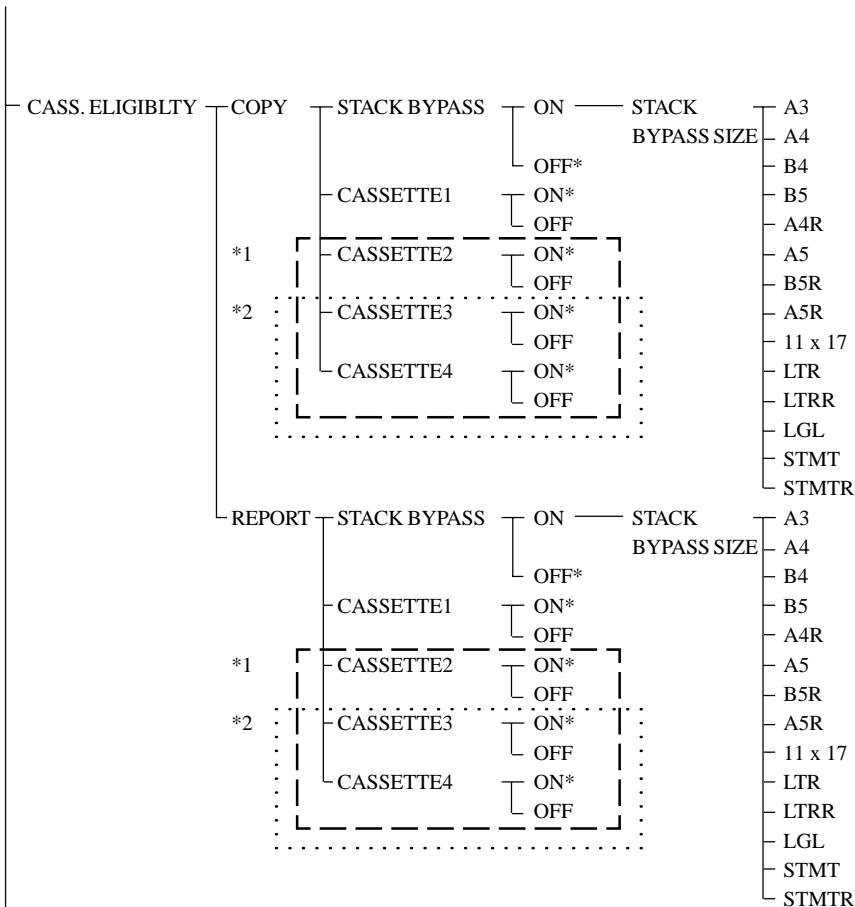

*1 : Enabled for the iR1600 and if equipped with a 1-/3-cassette unit.

*2 : Enabled for the iR2000 and if equipped with a 2-cassette unit.

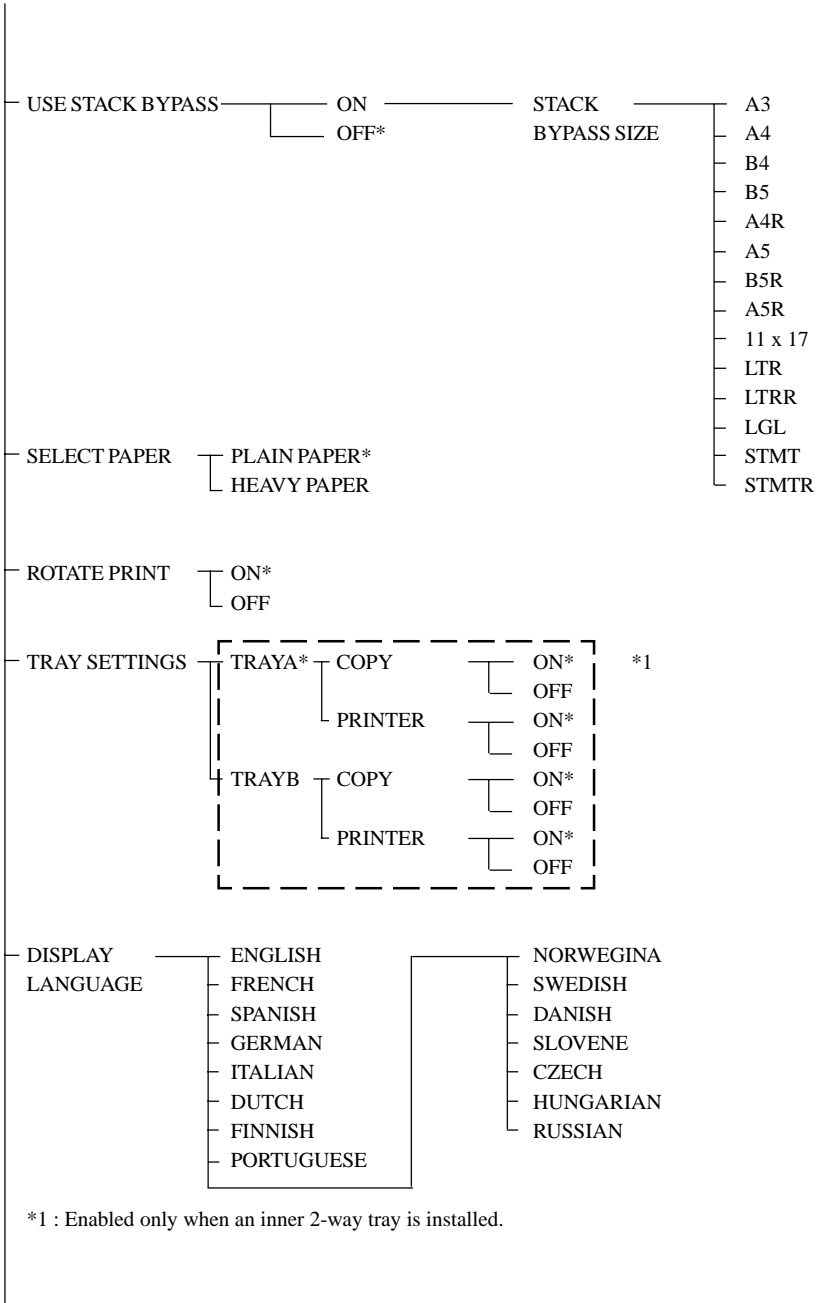

COPY SETTINGS

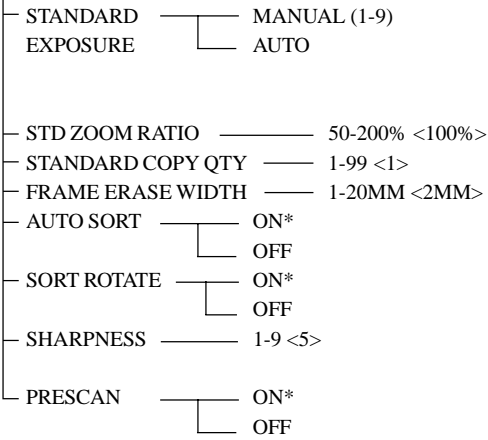

TEIMER SETTINGS

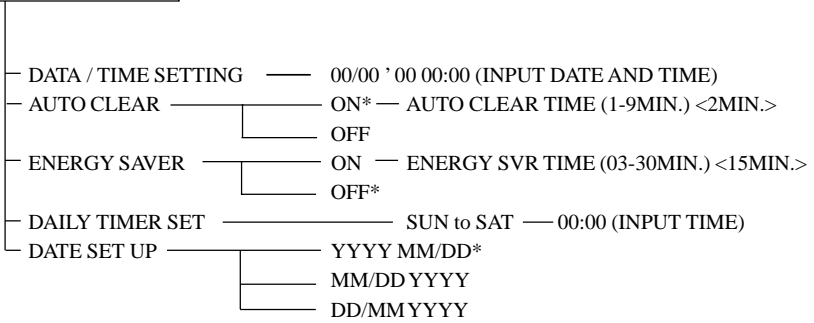

SYSTEM SETTINGS

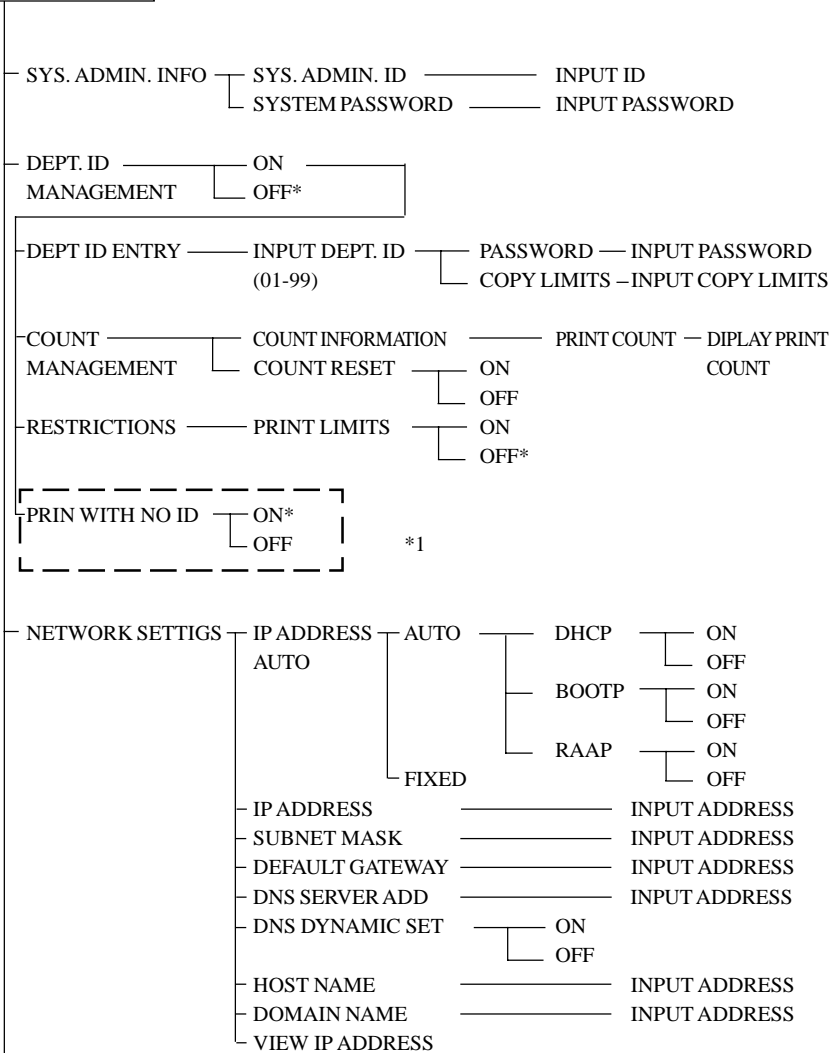

*1 : Enabled only when a network printer function is used.

ADJUST/CLEAN

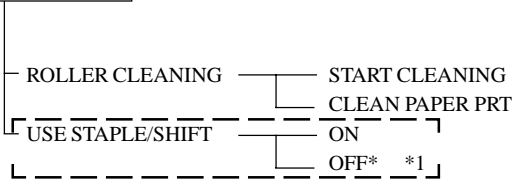

*1 : Enabled only when a finisher is installed.

PRINT LISTS

- USER DATA
- DEPT. INFO LIST
- CANCEL REPORT

5 Cleaning by the User

5.1 Cleaning by the User

Instruct the user to provide the following maintenance on a regular basis, including the cleaning of the following once a month:

- Fixing roller
- Copyboard glass, reading glass, and copyboard cover

5.1.1 Cleaning the Fixing Roller

Advise the user to clean the fixing roller for the following:

- when the cartridge has been replaced.
- when black lines appear on printed paper.

To clean, go through the following:

- 1) Place A4 or LTR paper in the cassette or manual feed tray.
- 2) Press the Additional Functions key to bring up the User Mode screen.
- 3) Using the cursor key, select “5. ADJUST/CLEAN”, and press the OK key.
- 4) Using the cursor key, select “02 CLEAN PAPER PRT”, and press the OK key so that the paper will automatically be picked up and the following output will be generated:

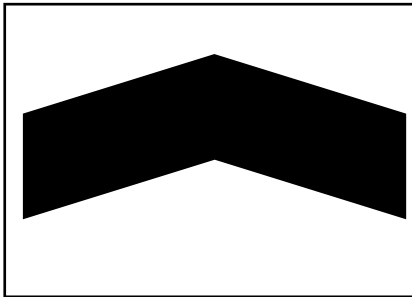

F01-501-01

- 5) Paying attention to the orientation of the output, place it as shown.

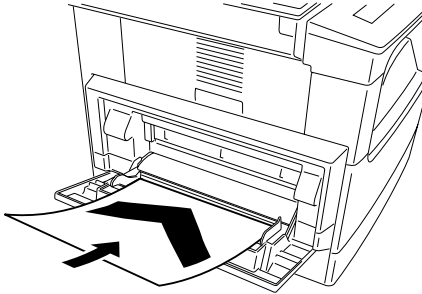

F01-501-02

- 6) Go through steps 2) through 3), and select “01 START CLEANING” using the cursor key; then press the OK key so that the cleaning paper will automatically be picked up and the fixing roller will be cleaned.



Memo

It takes about 3 min between when cleaning starts and when the cleaning paper is delivered to the delivery tray.

- 7) See that the cleaning paper has been delivered, indicating the end of cleaning.

5.1.2 Cleaning the Copyboard Glass, Reading Glass, and Copyboard Cover White Plate

- 1) Clean the copyboard over white plate [1], copyboard glass [2], and reading glass [3] with a cloth moistened with water (well wrung); then, dry wipe them.

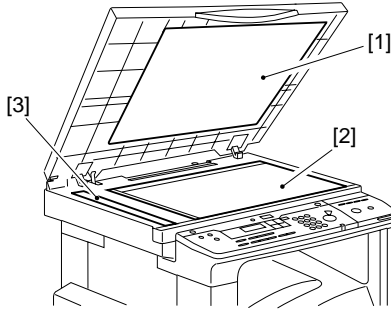

F01-501-03

6 Safety and Warnings

6.1 Safety of Laser Light

The radiation from a laser until can be harmful to the human body. The machine's laser optical unit is sealed by means of a protective housing and external covers, so that the light it produces will not escape outside, ensuring the safety of the user as long as the machine is used under normal conditions.

6.2 CDRH Requirements

The Center for Devices and Radiological Health (CDRH) of the US Department of Health and Human Services put into force a set of requirements with a view to regulating laser-related products on August 2, 1976. The requirements apply to laser products produced on August 1, 1996, or later, and all laser products must comply with them if they are to be marketed in the US. The following is the label that indicates the compliance with the CDRH requirements, and it must be attached to all laser products that are sold in the US.

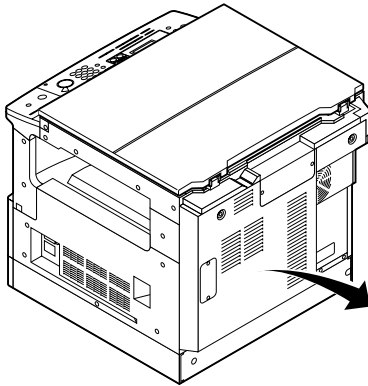

CANON
30-2, SHIMOMARUKO, 3-CHOME, OHTAKU, TOKYO,
146, JAPAN.

MANUFACTURED:
THIS PRODUCT CONFORMS WITH CDRH RADIATION
PERFORMANCE STANDARD 21CFR CHAPTER 1
SUBCHAPTER J.



The text may differ from product to product or from model to model.

F01-602-01

6.3 Handling the Laser Unit

When servicing the area around the machine's laser optical unit, take full care not to put any tool with a high reflectance (e.g., screwdriver) into the laser path. Be sure also to remove any watch, ring, or the like, as they can reflect the laser beam to damage your eye. The machine's laser light is red, and its covers that can reflect the laser light are identified using the following label; take special care if you must service the area behind covers to which the label is attached. (The label is also attached on covers used to block out the laser light.)

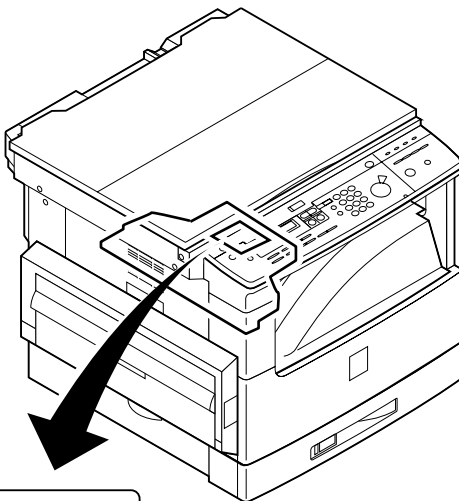

	DANGER - Invisible laser radiation when open. AVOID DIRECT EXPOSURE TO BEAM.
	CAUTION - INVISIBLE LASER RADIATION WHEN OPEN. AVOID EXPOSURE TO BEAM.
	ATTENTION - RAYONNEMENT LASER INVISIBLE EN CAS D'O UVERTURE. EXPOSITION DANGEREUSE AU FAISCEAU.
	VORSICHT - UNSICHTBARE LASERSTRAHLUNG. WENN ABDECKUNG GEÖFFNET, NICHT DEM STRAHL AUSSETZEN.
	ATTENZIONE - RADIAZIONE LASER INVISIBLE IN CASO DI APERTURA. EVITARE L'ESPOSIZIONE AL FASCIO.
	PRECAUCION - RADIAACION LASER INVISIBLE CUANDO SE ABRE. EVITAR EXPONERSE AL RAYO.
	VARO! - AVATTIASSA OLETTIINÄ NÄKYMÄTTÖMÄLLE LASERSÄTELYLLE. ÄLÄ KATSO SÄTEESEEN.
	WARNING! - OSYNLIG LASERSTRÅLNING NÄR DENNA DEL ÄR ÖPPNAD. BETRAKTA EJ STRÅLEN.
	ADVARSEL! - USYNLIG LASER STRÅLING. NÄR DENNE ER ÅBEN. UNDGÅ BESTRÅLING.
	ADVARSEL - USYNLIG LASERSTRÅLING NÄR DEKSEL ÅPNES. UNNGÅ EKSPONERING FOR STRÅLEN.
注意 - このカバーの内部では不可視レーザー光が放射されています。 レーザー光にさらされないようにしてください。	

F01-603-01

6.4 Safety of the Toner

The machine's toner is a non-toxic material consisting of plastic, iron, and small amounts of dye. If toner came into contact with your skin or clothes, remove as much of it as possible with dry tissue, and wash with water. Do not use hot water, as it will turn the toner into a jelly and cause it to permanently fuse with the fibers of the clothes. Also, do not bring toner into contact with vinyl material, as they are likely to react against each other.



Do not throw toner into fire. It may explode.

7 Reproduction Processes

7.1 Outline

The machine uses an indirect photoelectronic reproduction method, and it has the following construction:

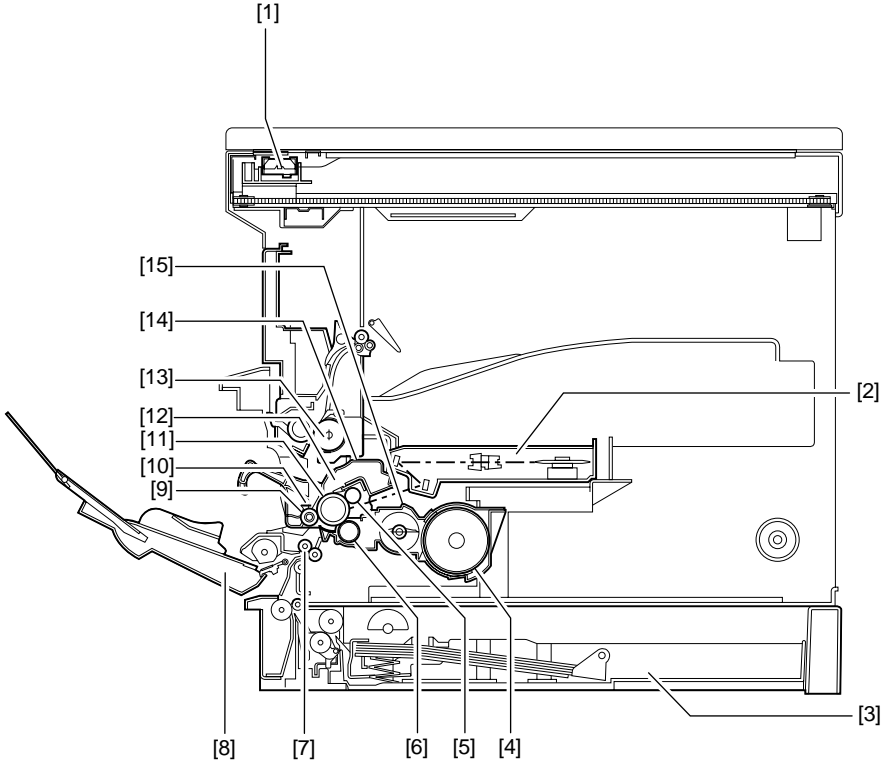

F01-701-01

- | | | | |
|-----|------------------------------------|------|--------------------------|
| [1] | CS (contact sensor) | [9] | Transfer charging roller |
| [2] | Laser/scanner unit | [10] | Static eliminator |
| [3] | Pickup (cassette) | [11] | Drum |
| [4] | Toner cartridge | [12] | Drum cleaner assembly |
| [5] | Primary charging roller | [13] | Fixing assembly |
| [6] | Developing cylinder | [14] | Drum unit |
| [7] | Registration roller | [15] | Developing assembly |
| [8] | Pickup assembly (manual feed tray) | | |

The machine is designed as a cartridge model, in which its drum, toner, primary charging assembly, developing assembly, and drum cleaner assembly are all constructed as a single entity.

The machine's image formation processes can be divided into the following 5 blocks (7 steps):

- [1] Latent Image Formation Block
 - Step 1 primary charging (AC + negative DC)
 - Step 2 laser beam exposure
- [2] Developing Block
 - Step 3 development (AC + negative DC bias)
- [3] Transfer Block
 - Step 4 transfer (positive DC)
 - Step 5 separation (grounding)
- [4] Fixing Block
 - Step 6 fixing
- [5] Drum Cleaning Block
 - Step 7 drum cleaning

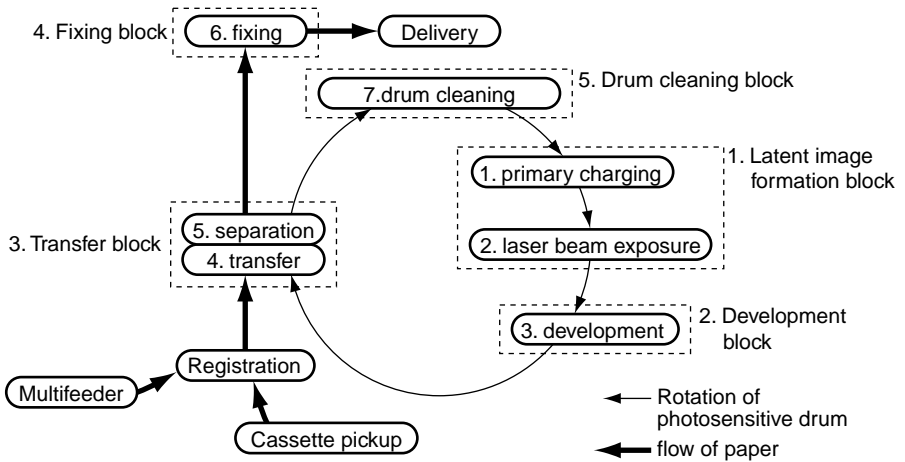

F01-701-02

CHAPTER 2

BASIC OPERATION

1 Basic Operation

1.1 Functional Construction

The machine may be divided into the following 6 functional blocks: pickup/feeding system, original reading/processing system, laser exposure system, image formation system, communication system, control system.

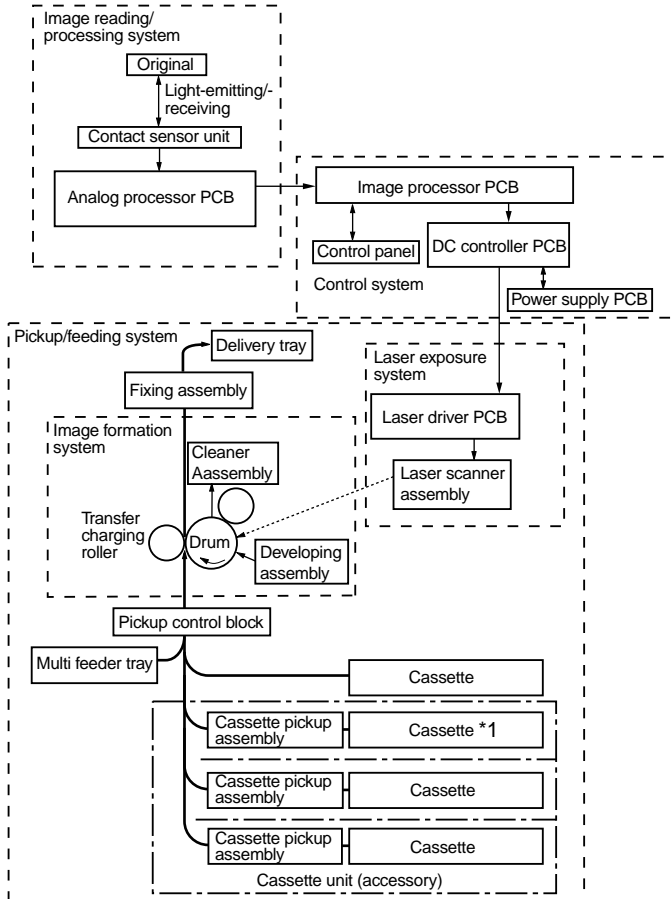

*1 : standard if iR2000

F02-101-01

1.2 Outline of Electrical Circuitry

The PCBs used to control the machine's major electrical mechanisms are as follows:

1.2.1 Image Processor PCB

The image processor PCB controls the machine as a whole:

a. Drive Control Block

The drive control block uses a motor control IC and motor driver IC to control the reader motor of the reader unit.

b. Control Panel Control Block

The control panel control block uses a control IC and serial communications of the control PCB to transmit/receive data, to receive statuses of the control buttons and originals, and to send display signal to the control IC of the control panel PCB for indication by LEDs and LCD.

c. Reader Control Block

The reader control block processes image data read from the CS unit, and stores the result in the SDRAM by means of DMA (direct memory access).

d. Printer Control Block

The printer control block converts 600x600-dpi image data into print data. It then sends the resulting print data to the printer unit in the form of image signals (VDO*, VDO) in response to the horizontal synch signal (BDO*) coming from the printer unit.

e. Sensor Detection

The sensor checks mechanism monitors the state of the reader unit and ADF to monitor the drive mechanism.

f. Energy Save Control Mechanism

The energy save control mechanism controls the energy save function (ESS) used to decrease the power consumption while the machine remains in wait state.

g. Memory Function

The SDRAM possessing 16 MB of memory (as mounted) is capable of storing image data equivalent of as many as 100 sheets (about 2 MB; A4; with print ratio of 4%).

The 128KB SRAM is used to store settings data (user data, service data), and is backed up by a lithium battery (BAT1; as long as 5 years with power removed).

The image memory may be expanded by adding a 32MB RAM DIMM.

h. SEND Function

The SEND function uses a network to send image scanned by the reader unit to an external device.

i. Speaker

The machine allows the control of the sound generated by the speaker in response to an error or button operation (on/off) and of the volume of the sound.



To control the volume of the sound, change the settings in user mode.

1.2.2 DC Controller PCB

a. Fixing Heater Control Mechanism

The fixing heater control mechanism monitors the readings of the thermistor mounted to the fixing heater and the level of direct current from the power supply in relation to voltage, thereby causing the temperature of the fixing heater to reach a specific level. It also cuts off power to the fixing heater in response to an error in the heater temperature.

b. High Voltage Control Mechanism

The high voltage control mechanism is used to control the high voltage applied to the primary charging roller and developing cylinder of the toner cartridge and the transfer charging roller of the toner transfer assembly.

c. Drive Control Mechanism

The drive control mechanism is used to control the main motor, pickup solenoid, and delivery fan.

d. Sensor Detection Mechanism

The sensor detection mechanism is used to check the sensor state of the printer unit and pickup assembly to monitor the drive mechanism.

e. Image Processor PCB Interface Mechanism

The image processor PCB interface mechanism sends the horizontal sync signal (BDO*) to the image processor PCB. Also, it returns status signals in response to the command signal for serial communications coming from the image processor PCB to communicate the state of the printer unit to the image processor PCB.

f. Laser Control Mechanism

The laser control mechanism controls the drive of the laser diode of the laser scanner unit according to the print data from the image processor PCB. Also, it performs laser power auto control (auto power control) for each line of print data.

g. Horizontal Sync Signal Control Mechanism

When the laser beam reaches a print start point for horizontal direction, the BD input signal (BDI*) coming from the laser scanner unit is detected, and the horizontal sync signal (BDO*) is sent to the image processor PCB. Also, the output of the scanner motor is monitored in relation to the horizontal sync signal (BDO*).

e. Scanner Motor Control Mechanism

The scanner motor control mechanism is used to control the drive of the scanner motor so that the horizontal resolution of print images will be 600 dpi. Also, the BD input signal (*BDI) from the laser scanner unit is detected to monitor the rotation of the scanner motor.

f. Toner Level Detection Mechanism

The level of toner inside the developing assembly is monitored in relation to the toner level detection signal (TNRCHKT), which is the result of comparison between the cartridge antenna output and the developing bias when the developing AC bias is applied for normal rotation during the warm-up time.

1.2.3 Power Supply PCB

The following are generated from the common AC power for supply to various loads: full-time ON system, (DC +12VS, DC +5VS, DC +3VS1, DC +3VS2), remote ON/OFF system (DC +24VR1, DC +24VR2, DC +5VR, DC +3VR).

1.2.4 Analog Processor PCB

The analog data read of an original by the CS unit is converted into digital data for output to the image processor PCB.

1.3 Inputs to and Outputs from Electrical Components

1.3.1 Wiring Diagram of the Major PCBs

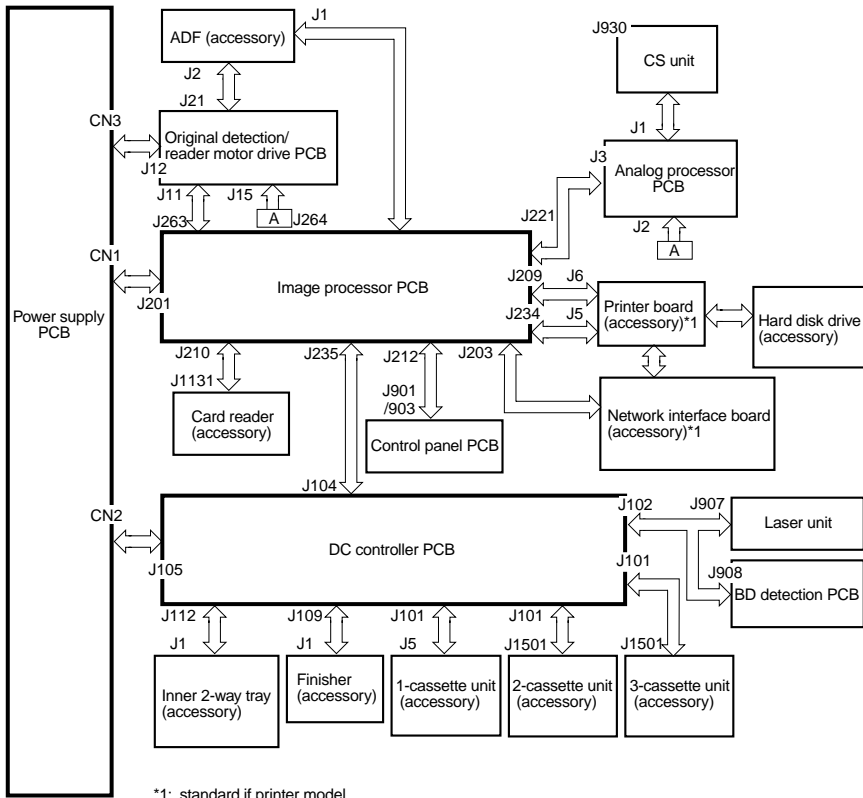

*1: standard if printer model.

Note: The symbol \longleftrightarrow in the diagram indicates a major connection, not the nature of a signal

F02-103-01

1.3.2 Wiring Diagram of the Electrical Components (1/2)

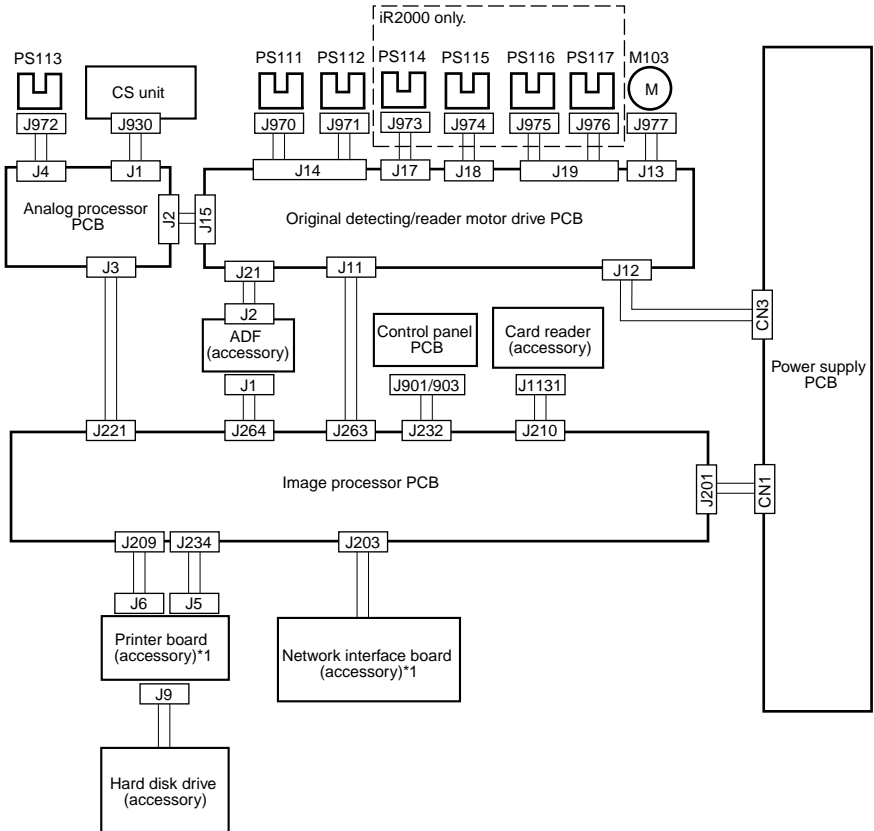

*1: standard if printer model.

F02-103-02

- | | |
|--|--------------------------------|
| PS111 : copyboard cover open/closed sensor | PS115 : original size sensor 2 |
| PS112 : ADF open/closed sensor | PS116 : original size sensor 3 |
| PS113 : CS unit HP sensor | PS117 : original size sensor 4 |
| PS114 : original size sensor 1 | M103 : reader motor |

1.3.3 Wiring Diagram of Electrical Components (2/2)

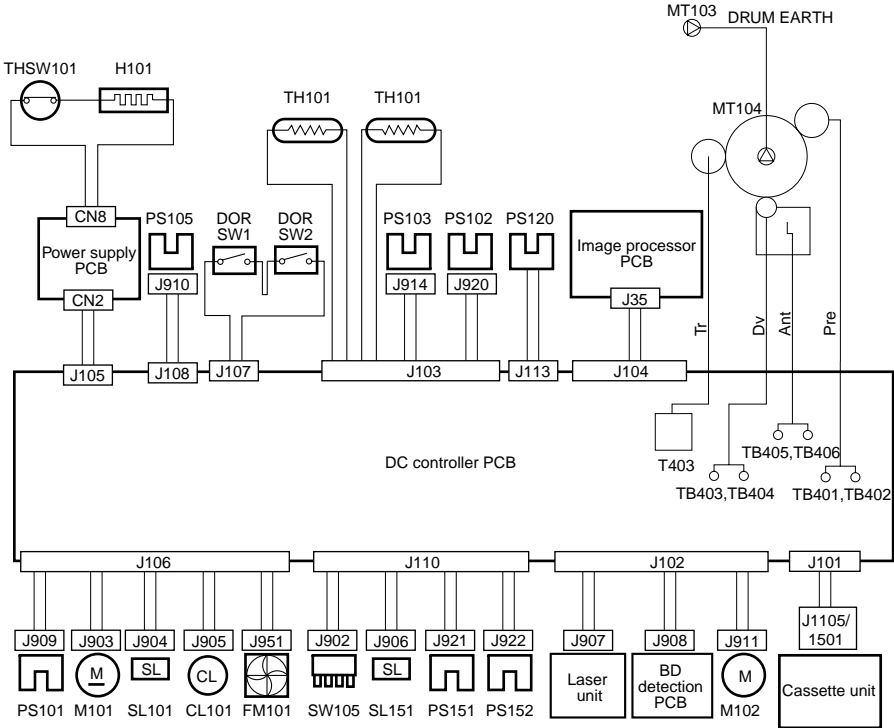

F02-103-03

- | | |
|--------------------------------------|-------------------------------------|
| PS101 : registration paper sensor | M101 : main motor |
| PS102 : paper full sensor | M102 : scanner motor |
| PS103 : delivery sensor | SW105 : paper size detecting switch |
| PS105 : multifeeper paper sensor | DORSW1 : front cover switch |
| PS151 : cassette paper sensor | DORSW2 : rear cover switch |
| PS120 : waste toner case full sensor | TH101 : thermistor |
| PS152 : re-try sensor | THSW101 : thermal switch |
| SL101 : multifeeper pickup solenoid | H101 : fixing heater |
| SL151 : cassette pickup solenoid | FM101 : heat discharge fan |
| CL101 : registration clutch | |

1.4 Basic Sequence of Operation

1.4.1 Outline

The machine stores the image data it collects by scanning an image in memory for printing (memory copying). The following are the conditions under which scanning or printing takes place in memory copying:

a. Scanner Start Condition

The Start key is enabled under the following condition so that the machine may start reading an original. However, the machine will not start printing until the printer start condition is met:

- The power switch is ON, and all external covers are closed.

b. Printer Start Condition

The machine is ready for printing when there is image data in page memory and the following condition is met:

- The surface temperature of the fixing roller has reached the target temperature (173°C in plain paper mode).

1.4.2 Basic Sequence of Operation (power-on)

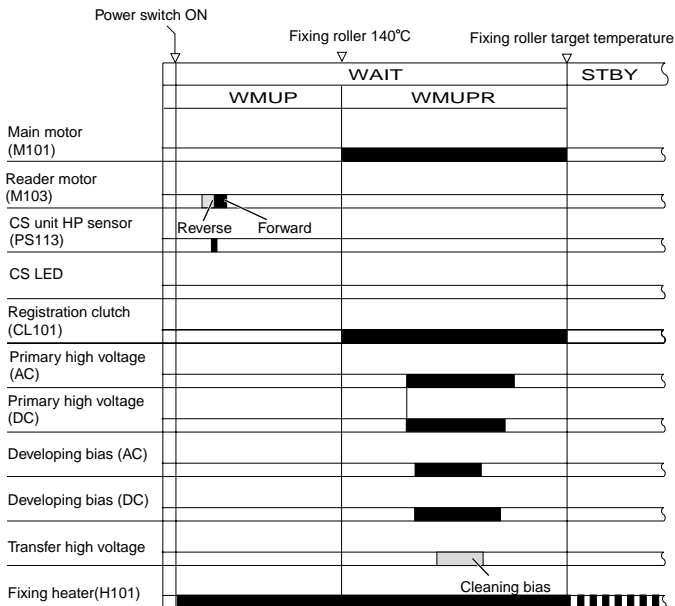

F02-104-01

Period	Description
WAIT (wait)	The machine shifts to standby state under the following conditions so as to reduce the wait time: <ul style="list-style-type: none"> · 25 sec passed and, in addition, the fixing roller surface temperature is 150°C or higher. · 27 sec passed and, in addition, the fixing roller surface temperature is 145°C or higher.
WMUP (warm-up)	From when the power switch is turned on until the fixing roller surface temperature reaches 140°C.
WMUPR (warm-up rotation)	From when warm-up ends until the main motor is turned on and stopped.
STBY (standby)	From when WMUPR ends until the Start key is pressed or the power switch is turned off.

T02-104-01

1.4.3 Basic Sequence of Operation (printing)

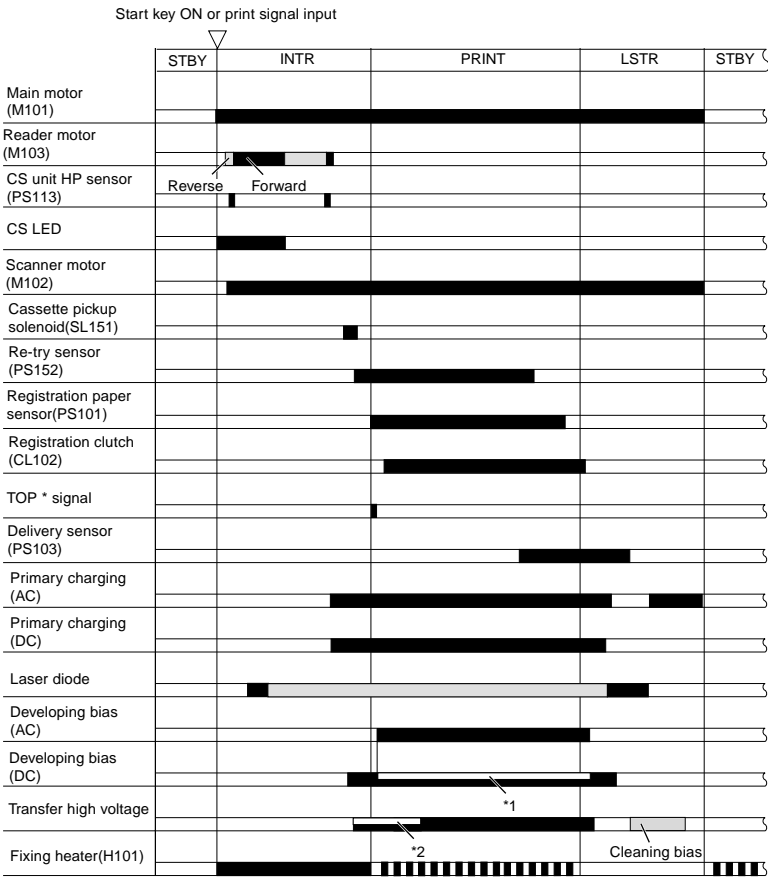

F02-104-02

Period	Description
STBY (standby)	From when warm-up rotation ends, or last rotation ends, until when the start key ON signal or the print signal arrive from the image processor PCB.
INTR (initial rotation)	From when the print signal is generated by the image processor PCB until when paper reaches the registration roller.
PRINT (print)	From when paper is moved from the registration roller until toner is transferred to the paper.
LSTR (last rotation)	From when printing ends until when the main motor stops.

T02-104-01

1.5 Controlling the Main Motor (M101)

1.5.1 Outline

The following table shows the functions of the main motor control circuit, while the following mechanism diagram shows the construction of the circuit:

Item	Description
Power supply	24 V supplied from DC controller PCB
Drive signal	MTRON from DC controller PCB
Operation mechanism/ drive mechanism	Registration roller Multifeeder pickup assembly Cassette pickup assembly 1-cassette unit pickup assembly Fixing roller drive assembly Image formation roller drive assembly
Control	ON/OFF control Constant speed control
Error detection	'E010'

T02-105-01

- [1] When the main motor drive signal (MTRON) goes '1', the main motor starts to rotate.
- [2] When the main motor has started to rotate and reached a specific revolution, the motor causes the main motor rotation detection signal (MLOK*) to go '0'. If the DC controller PCB detects an error in the rotation detection signal, it will indicate 'E010' in the control panel.

F02-105-01

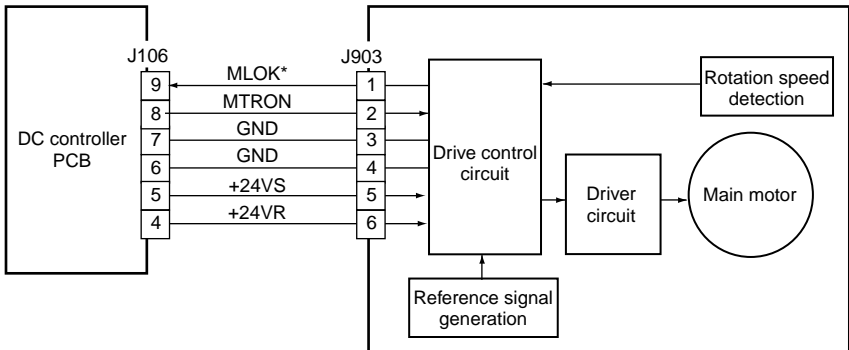

CHAPTER 3

IMAGE READING/PROCESSING SYSTEM

1 Outline of Operation

1.1 Outline

The image reading/processing system has the following major functions:

Item	Description
Original exposure	Indirect exposure by LEDs (LEDs + photo conducting medium)
Original scanning	Book mode: scanning by moving carriage ADF mode: stream reading by fixed carriage
Original size detection	Book mode: detection by reflection type sensor (in models equipped with original size sensor) ADF mode: detection by ADF
Enlargement/ reduction (zoom)	Between 50% and 200% (in 1% increments) Main scanning direction : image processing by image processor Sub scanning direction : Book mode : by varying speed of carriage ADF mode : by varying speed of original
Lens	Rod lens array
Contact sensor	Number of lines : 1 (7084 pixels) Maximum original reading width : 299.8 mm
Contact sensor unit drive control	Control by reader motor (M103)
Contact sensor unit position detection	By CS unit HP sensor (PS113)
Shading correction	Reading in units of 10 bits, output in units of 8 bits Correction on all black/white pixels Executed at the start of a read job.
Auto density correction	By ABC (auto background control) Executed for every line in main scanning direction (Executes density correction for every line in main scanning direction, and consists in a single scan.)

T03-101-01

2 Reader Drive System

2.1 Outline

The reader drive system consists of the following: reader motor, drive pulley, carriage, carriage rail, carriage drive belt.

The drive signal from the image processor PCB is sent to the reader motor (M103) by way of the driver circuit on the original detection/reader motor drive PCB. The drive from the reader motor is transmitted to the carriage by way of the drive pulley and drive belt to move the carriage forward or in reverse.

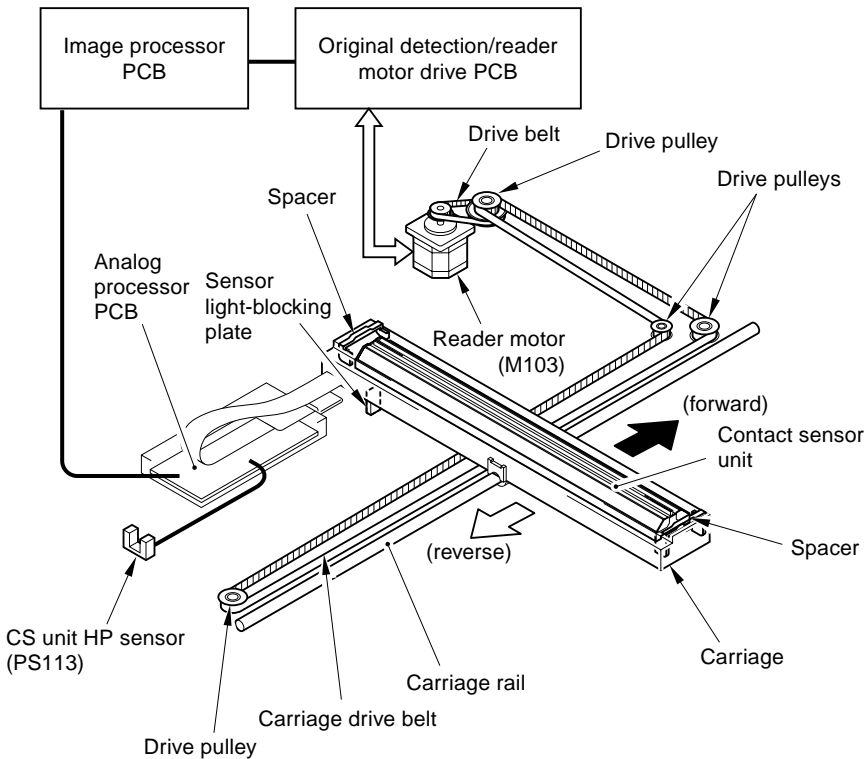

F03-201-01

2.2 Controlling the Reader Motor

The following shows the circuit used to control the reader motor, and the circuit has the following functions:

- (1) Controlling the direction of rotation of the reader motor
- (2) Controlling the speed of rotation of the reader motor
- (3) Turning on/off the reader motor

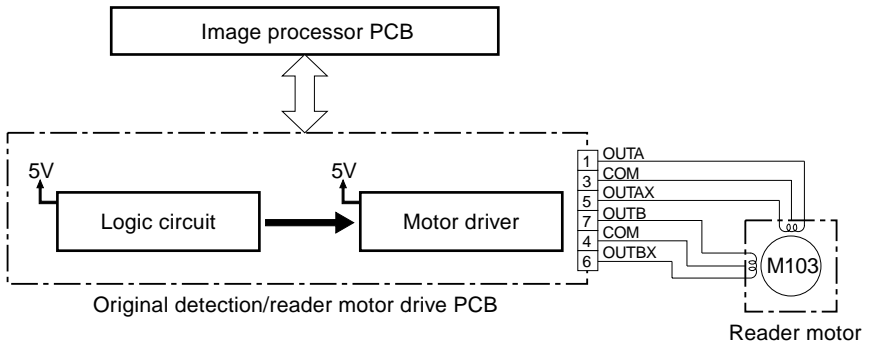

F03-202-01

2.2.1 Moving the Carriage in Reverse After an Image Scan

The speed at which the carriage is moved in reverse (after an image scan) is constant, i.e., 50% of the speed used to move it in Reduce mode.

3 Detecting the Size of Originals

3.1 Outline

The machine detects the size of an original in either of the following two ways, and it uses the result of detection for auto paper selection (APS) and auto enlargement/reduction (AMS):

- [1] Detection by original size sensors (in models equipped with original size sensor)
- [2] Detection by feeder (in models equipped with ADF)

3.2 Detection by the Original Size Sensors

The machine uses the original size sensors to detect the size of an original placed on its copyboard glass (i.e., based on the combination of the output levels of the sensors).

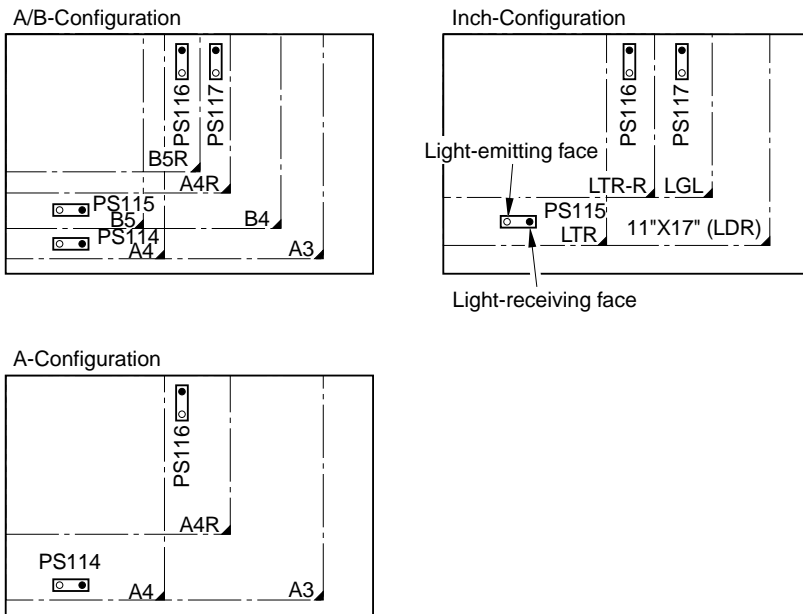

F03-302-01



#5 TYPE> (selecting the country/region)

The paper configuration detected by the original size sensors (A/B, Inch, A) is set automatically when a country of installation is selected.

When the copyboard cover is closed to about 30°, the copyboard cover open/closed sensor (PS111) goes ON. The original detection/reader motor drive PCB reads the output levels of the original size sensors at intervals of 0.125 sec for 15 sec after the copyboard cover open/closed sensor goes ON or between when the copyboard cover open/closed sensor goes ON and when the Start key is pressed. If it detects a change in the level, it identifies the condition as the absence of an original; if there is no change, it will identify the condition as the presence of an original. This way of identification enables the machine to detect the size of a black original.

In the case of conditions a and b in the following, the output level of the sensor remains unchanged, at times causing the machine to make the wrong detection. If, for condition c, i.e., A3 (11x17) is selected with priority and A3 (11x17) paper is absent, the cassette selected for standard mode will be selected.

- a. A3 (11x17) Black Original
- b. Book original (The thickness of the original prevents the copyboard cover from closing fully, making it difficult to detect a change in the sensor level.)
- c. Copyboard cover (not closed)

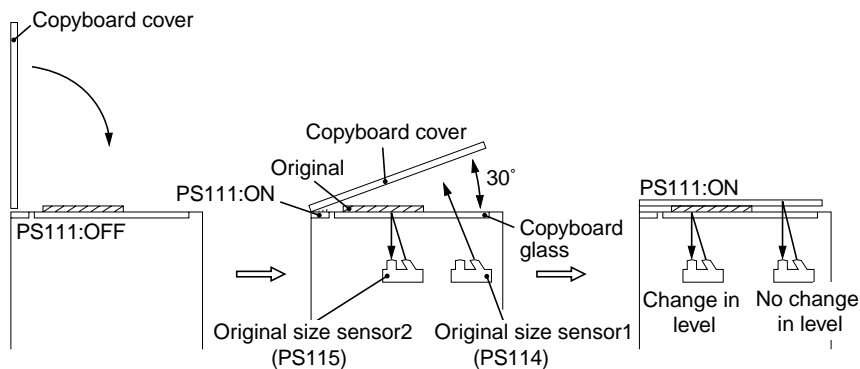

F03-302-02

3.3 Detecting the Size of Originals

The machine uses combinations of states of original size sensors to detect the size of an original with reference to the following table:

- **Unchanged** : The machine reads the output levels of the sensors at intervals of 0.125 sec after the copyboard cover open/closed sensor goes ON, and there is no change in the output level (detecting an original).
- **Changed** : The machine reads the output levels of the sensors at intervals of 0.125 sec after the copyboard cover open/closed sensor goes ON, and there is change in the output level (not detecting an original).

A/B-Configuration

Original size	Original size sensor			
	PS114	PS115	PS116	PS117
A3	Unchanged	Unchanged	Unchanged	Unchanged
B4	Changed	Unchanged	Unchanged	Unchanged
A4R	Changed	Changed	Unchanged	Unchanged
A4	Unchanged	Unchanged	Changed	Changed
B5	Changed	Unchanged	Changed	Changed
B5R	Changed	Changed	Unchanged	Changed
None	Changed	Changed	Changed	Changed

Inch-configuration

Original size	Original size sensor		
	PS115	PS116	PS117
11"X17"	Unchanged	Unchanged	Unchanged
LGL	Changed	Unchanged	Unchanged
LTR-R	Changed	Unchanged	Changed
LTR	Unchanged	Changed	Changed
None	Changed	Changed	Changed

A-configuration

Original size	Original size sensor	
	PS115	PS116
A3	Unchanged	Unchanged
A4R	Changed	Unchanged
A4	Unchanged	Changed
None	Changed	Changed

T03-303-01

3.4 Detection by the ADF

The ADF uses the 2 sensors (length sensors) in its original tray and the 2 sensors (width sensor) to detect the size of originals. The ADF is capable of detecting the following sizes:

A-configuration : A5, A5R, A4, A4R, A3

B-configuration : B6, B5, B5R, B4

Inch-configuration : STMT, STMTR, LTR, LTRR, LGL, 11" x 17" (LDR)

4 Image Processing

4.1 Outline

The machine performs image processing and correction in copier mode as shown in the following block diagram.

The image data (analog signals) read by the contact sensor is converted into digital signals by the analog processor PCB. The resulting image data is subjected to processing/correction by the analog processor PCB and image processor PCB.

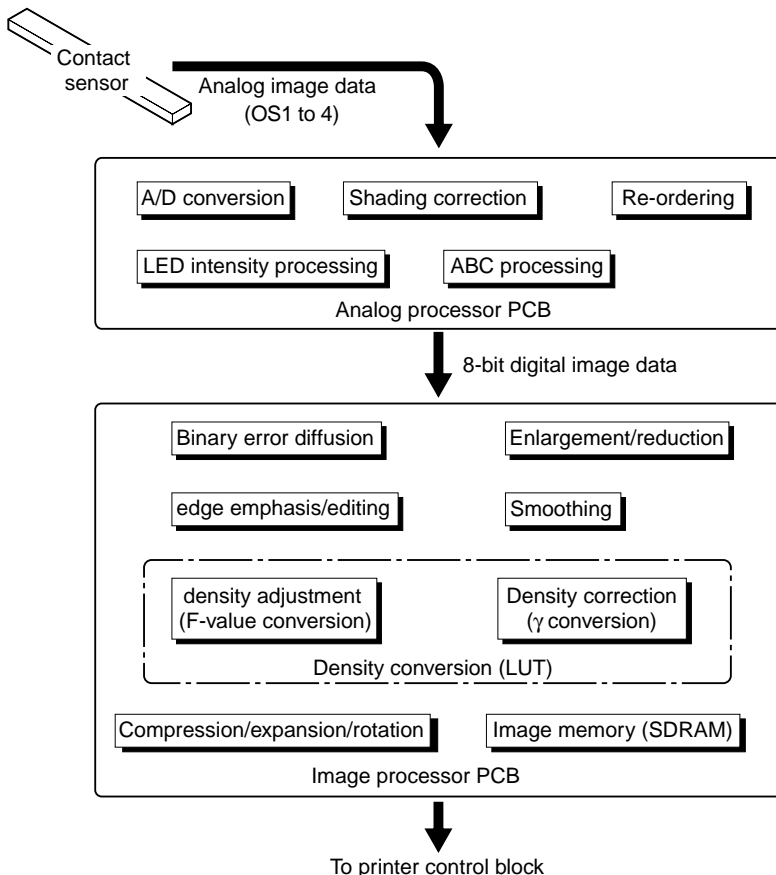

F03-401-01

4.2 Contact Sensor

4.2.1 Outline of the Contact Sensor

The machine uses a contact sensor (CS) for original exposure and original reading.

The CS is a single module consisting of the following, and is used to read images in lines: 2 sets of LEDs (R, G, B); photo conducting medium used to shine the light of the LEDs across a single image line of an original; rod lens array used to collect reflected light by the original; CCD array used to detect reflected light. It reads an image line by line.

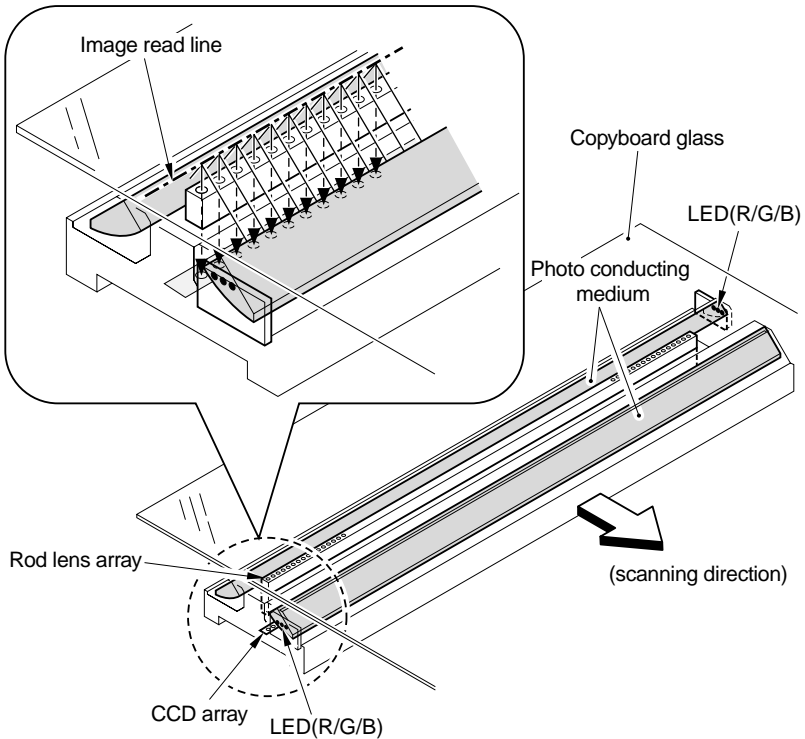

F03-402-01

4.2.2 Construction of the Contact Sensor (CS)

The CS has the following construction:

The LEDs used to expose an original are grouped in two (R, G, B), and are mounted to the edge of a photo conducting medium made of transparent glass. When an original is exposed, the LEDs (all three colors) go ON, and their light is directed to the original by way of the photo conducting medium. The light reflected by the original is collected by the rod lens array and detected by the CCD array, which will convert the light into electrical signals (photo-electric conversion) for output.

The CCD array is made up of 11 CCD device units, which are grouped into 4 systems in terms of control: 3 units x 3 systems and 2 units x 1 system; all systems are used to read an image or generate image signals at the same time, thus enabling high-speed operation.

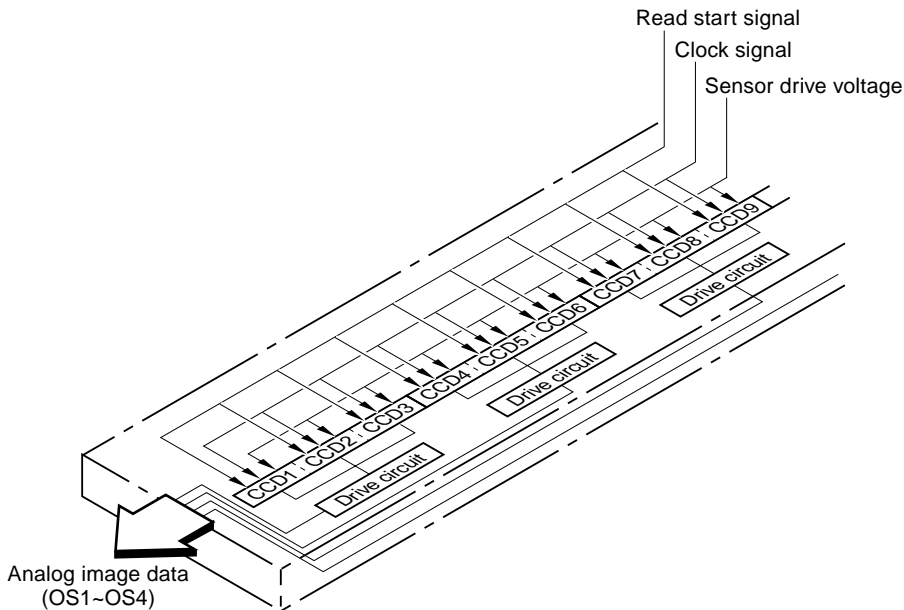

F03-402-02

4.3 A/D Conversion

The image data (analog signals) from the CS are converted into 10-bit digital signals. At this time, gain adjustment is executed to increase the level of the input signals to suit conversion by the A/D converter.

The size of the increase at time of gain adjustment is determined when gain adjustment is executed in service mode. During gain adjustment, the CS unit shines LED light against the standard white plate to measure the density of the white plate. The data is subjected to computation, and the result is store in memory as the gain adjustment value.



TEST MODE > [2] CCD TEST > [8] (executing gain adjustment)

When adjustment ends normally, the display indicates 'OK'. If it indicates 'NG', check the following take appropriate action:

- Is the copyboard cover (ADF) closed?
 - Is the copyboard glass mounted correctly? (Check the position of the standard white plate.)
 - Is the standard white plate soiled
 - Is the lens area of the CS lens soiled?
-

4.4 Shading Correction

The light reflected by an original and read by the CS, even if the original is completely uniform in density, will not necessarily be even in relation to image signals corresponding to pixels on the original for the following factors:

- [1] The intensity of a specific LED is not the same as that of other LEDs.
- [2] The intensity of reflected light collected by the rod lens array is not even.

Shading correction is executed to correct any discrepancy caused by these factors, and it may take the form of black shading correction or white shading correction.

4.4.1 Black Shading Correction

The input signal of the CS while the LEDs are kept OFF is read, and is subjected to A/D conversion (black correction), storing the result (digital signal) in memory.

When an image is read, the black correction value is subtracted from the value of the image signal read by each pixel of the CS by way of full pixel black shading correction.

4.4.2 White Shading Correction

The light of the LEDs is directed against the standard white plate, and the CS input signal is read. The result is subjected to A/D conversion (white correction), storing the result (digital signal) in memory.

The image data to which black shading correction was executed is then subjected to computation using the white correction value, thus executing full pixel white shading correction. As a result, the variation in LED intensity and in the intensity of the rod lens array are corrected, evening out the image density level.

Shading correction is executed as follows:

- When the Start key is pressed.

The image data after shading correction is converted from 10-bit into 8-bit data.

4.5 Re-Ordering

The input signals from the CS consist of image data read simultaneously by each of the 4 systems of CCD device units; thus, they are not in the same sequence as the signals that represent the original image, re-ordering.

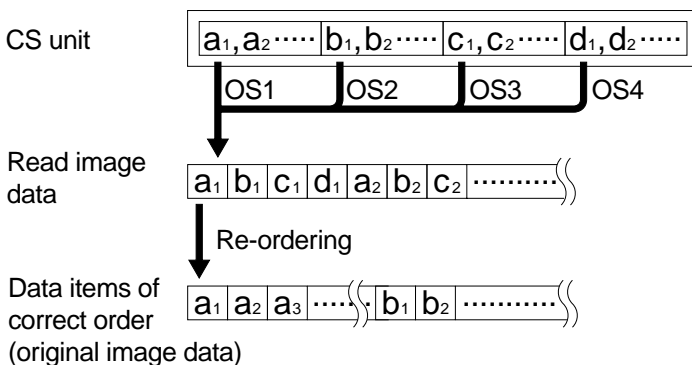

F03-405-01

4.6 ABC (auto background control)

The ABC function is used when the original has a dark background, not reproducing the color of the background while correctly reproducing the text and images of the original.

The machine's ABC function is enabled when the density adjustment function is set to 'auto' in copier mode; if selected, the ABC circuit is used for the work.

The digital image signals which are the result of A/D conversion are subjected to variation of dynamic range to suit the level of the background color of the original so that the machine will recognize the background to be "white."

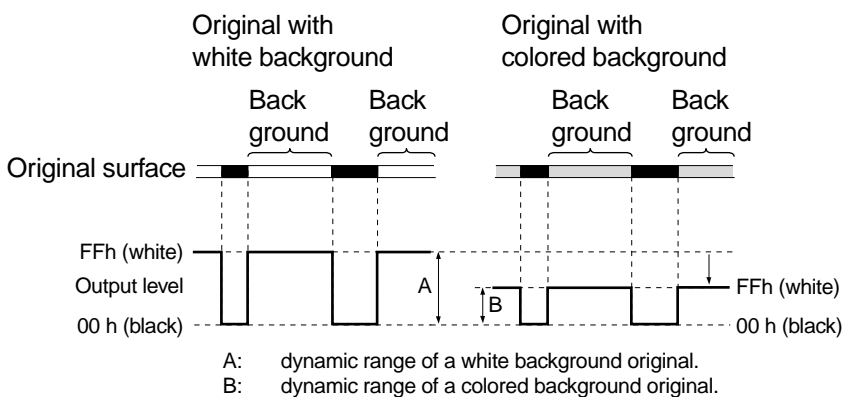

F03-406-01

As shown, range A of a white background original is decreased like range B of a colored background original to remove the color from its background.

4.7 LED Intensity Adjustment

So that the image data read by the CS unit will always be optimum, the length of time during which the LEDs are ON when reading a single line is controlled.

In LED intensity adjustment, the light of the LEDs is directed to the standard white plate during pre-scanning, and the image data thus collected is evaluated to see if it is within a specific range; if, for instance, it is outside the range, the length of time is decreased.

4.8 Enlargement/Reduction

The machine allows enlargement/reduction between 50% and 200%, set in increments of 1%.

4.8.1 Enlargement/Reduction in Main Scanning Direction

The ratio in main scanning direction (drum axial direction) is changed as follows: in book mode and ADF mode, the original is read at 100%; thereafter, the collected data is subjected to processing by the image processor PCB to suit the selected reproduction ratio.

The machine varies the ratio based on a linear correction method.

The CCD inside the CS unit is fixed in position so that the position of each pixel within the image data generated by reading an original is also fixed in position. To vary the reproduction ratio, the position of each pixel, therefore, must be changed. However, since the CCD is not found at each specific position, the machine relies on computation to generate image data that expresses a selected ratio; specifically, the original image data items indicating the 2 points before and after a specific pixel are subjected to computation, with the result indicating pixels enlarged/reduced to a specific ratio.

Enlargement

CCD read position
(in Direct)

Virtual CCD read position
(for enlargement)

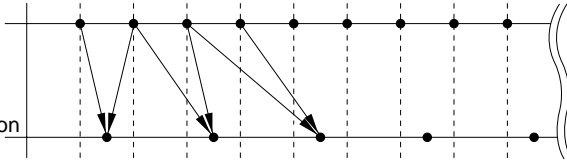

Reduction

CCD read position
(in Direct)

Virtual CCD read position
(for reduction)

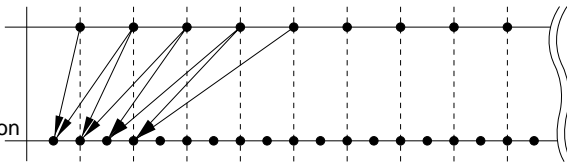

F03-408-01

4.8.2 Changing the Reproduction Ratio in Sub Scanning Direction

The reproduction ratio in sub scanning direction (paper feed direction) is changed by controlling the speed at which the carriage is moved in book mode or the speed at which original is moved in ADF mode.

The speed at which the carriage is moved (the original is moved by the ADF) is increased for reduction or decreased for enlargement, thereby changing the width of the scanning line per pixel.

[1] enlargement

The speed at which the carriage is moved or the original is moved by the ADF is decreased in relation to Direct; e.g.,
for 200%, the speed is halved from 100%.

[2] 50% and 99%

The speed at which the carriage is moved or the original is moved by the ADF is increased in relation to Direct; e.g.,
for 50%, the speed is doubled from 100%.

4.9 Edge Emphasis

Edge emphasis prevents blurred or crushed outlines of images by enhancing the changes in density, bringing about well defined images and enabling faithful reproduction of characters in test mode.

4.10 Editing

The machine offers blanking/masking, negative/positive reversal, and the like as editing functions.

4.11 Density Conversion (LUT, i.e., look-up table processing)

In this block a data conversion table is used to convert intensity signals into density signals or to enable the best output density curve for each mode.

4.11.1 Density Adjustment (F-value conversion)

An F-value conversion table best suited to the copy density selected in the control panel is used to adjust density.

4.11.2 Density Correction (γ correction)

In γ correction, the contrast and the density of image data are corrected. When an image is read, the image data is subjected to conversion using a γ conversion table.

4.12 Binary Processing

The machine uses an error diffusion method to convert 8-bit (256-gradation) image data into 1-bit (binary) image data.

4.12.1 Error Diffusion

To convert 8-bit (256-gradation) image data into 1-bit (2-gradation) image data, the machine tries to find out whether the level of a specific image signal is higher or lower than a threshold level: 8-bit image data (0 through 255) into 2-bit image data (0, 1). At this time, the difference of the signal from the threshold level is “diffused” to its adjacent signals (pixels) to express the gradation (dark, light) of the original image.

4.13 Image Memory Control

The image memory is used as follows:

4.13.1 Compression/Expansion, Rotation, and Enlargement/Reduction

The machine uses image memory to subject binary image signals to compression/expansion, rotation, and the like.

4.13.2 SDRAM

The machine uses image memory to store image data for image memory functions.



The machine is designed for memory copying only (no direct copying). The machine stores the image data once in its memory before generating output, at times resulting in inadequate available space when continuous copying is under way with the ADF in use. In such an event, the machine will stop reading the original, generate copy output, and resume reading when adequate space has been created.

4.14 Output Image Processing

The output image data sent to the printer unit is subjected to the following processing:

4.14.1 Smoothing

The machine uses smoothing to remove the jaggy edges from diagonal or curved lines of images, thus producing images consisting of smooth lines. Using smoothing, the machine can make moire associated with photo originals less conspicuous.

a. When Generating Read Images



The machine converts an 600x600-dpi input image into data of 1200 (equivalent) x 600 dpi by smoothing, which is carried out by relocating specific pixels in question.

b. When Generating Printer (PDL) Images

PDL data is subjected to appropriate smoothing, thus converting images of 600 x 600 dpi into images of 2400 (equivalent) x 600 dpi.

5 Disassembly and Assembly

Here, instructions on how to disassemble/assemble the machine are given together with explanations of its mechanical characteristics; be sure to keep the following in mind when going through the work:

1.  Before starting the work, be sure to disconnect the power plug. Moreover, if you have removed the drum unit, be sure to keep it in a protective bag.
2. Unless otherwise specially indicated, reverse the steps used to disassemble the machine when assembling it.
3. Identify the screws by type (length, diameter) and location.
4. To ensure electrical continuity, the mounting screws used for the grounding wire and arrestors are equipped with toothed washers. Do not leave them out when assembling the machine.
5.  As a rule, do not operate the machine with any of its parts removed.

5.1 Copyboard Glass

5.1.1 Removing the Copyboard Glass

- 1) Open the copyboard cover or the ADF.
- 2) Remove the 2 screws [1], and detach the copyboard glass retainer (right) [2].

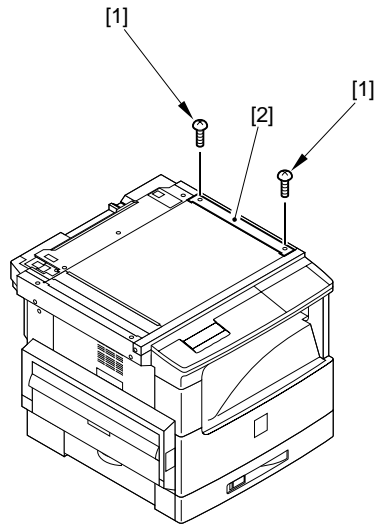

F03-501-01

- 3) Remove the copyboard glass [3].

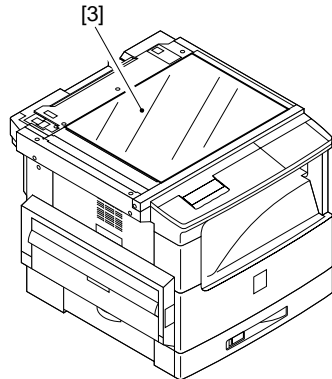

F03-501-02



Take care not to deform the right upper frame [1] when you have removed the copyboard glass. If deformed, the frame will come into contact with the CS unit, damaging the latter.

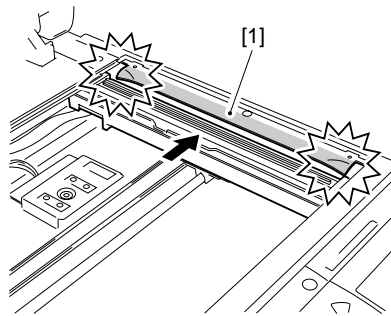

F03-501-03

5.1.2 After Replacing the Copyboard Glass

If you have replaced the copyboard glass, be sure to perform 'gain adjust' in service mode. (Refer to 5.1.1)

5.2 CS Unit

5.2.1 Removing the CS Unit

- 1) Remove the copyboard glass. (Refer to 5.1.1)
- 2) Move the belt [1] with your finger to move the CS unit [2] near the center of the copyboard.

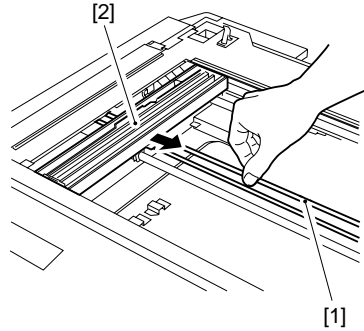

F03-502-01

- 3) Remove the 3 screws [3].

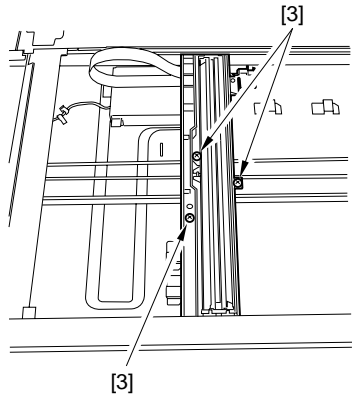

F03-502-02

- 4) While lifting the carriage [4] slightly, slide the rail guide [5] to detach the rail guide from the carriage.

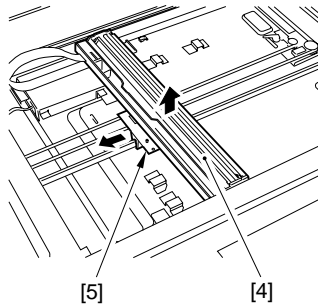

F03-502-03

- 5) Slant the carriage [6] so that the frame top is out the frame inside.

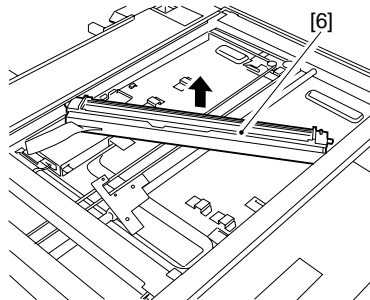

F03-502-04

- 6) Free the hook [7], and detach the flexible guide [8].

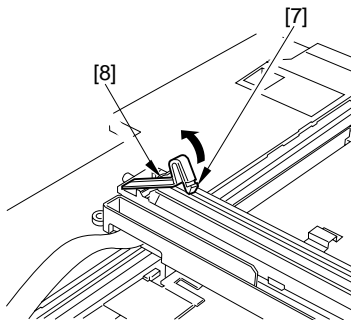

F03-502-05

- 7) Lift the CS unit [10] from the carriage [9] to free the lock [11] of the connector; then, detach the flexible cable [12], and detach the CS unit [10].

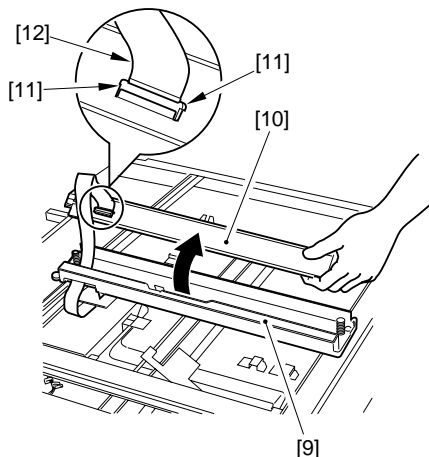

F03-502-06



Do not loosen or remove the 3 screws [2] found on the rail guide [1]. They are adjusted to high accuracy at the factory.

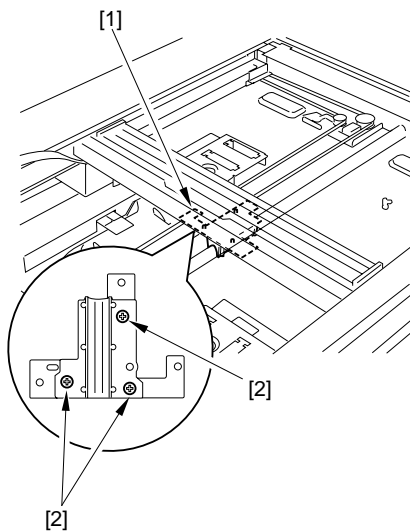

F03-502-07



After mounting the CS unit, do not turn on the power switch while the CS unit is at the left edge. Otherwise, the machine will not be able to detect home position normally, causing the reader motor to go out of sync.

5.2.2 Points to Note When Mounting the CS Unit



When mounting the belt re-
tainer [1], be sure that the boss
[2] is securely fitted.

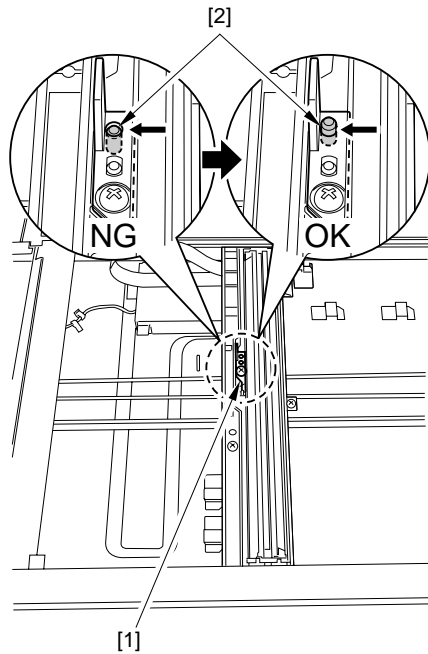

F03-502-08



When mounting the CS unit, check to make sure that the belt retainer [1] is keeping the drive belt [2] firmly in place.

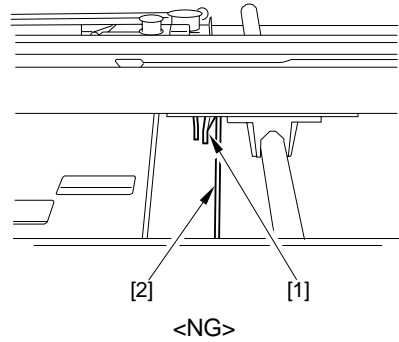
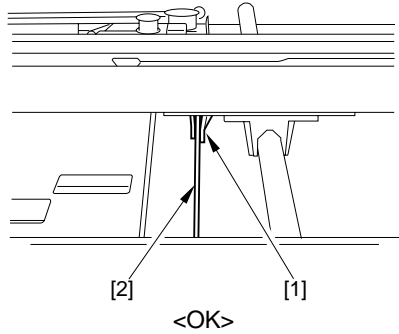

F03-502-09



After mounting the CS unit, move the drive belt [2] with your finger to make sure that the teeth will not skip.

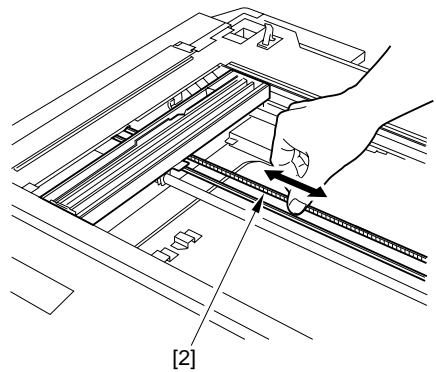

F03-502-10



When mounting the CS unit, be sure to fit the flexible cable [3] fully straight in relation to the connector [4] and secure it in place using the lock [5].

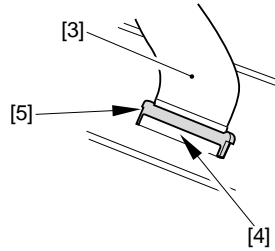

F03-502-11

5.2.3 After Replacing the CS Unit

If you have replaced the CS unit, be sure to execute 'gain adjustment' and 'CS position auto adjustment for ADF' in service mode. (Refer to Chapter13)

5.2.4 Points to Note When Handling the CS Unit



The electrical elements in the CS unit are vulnerable to static charges. As such, be sure to free yourself of static charges before starting the work. Moreover, avoid working in an environment where static charges tend to occur.



When handling the CS unit, take care not to leave oils or dirt from your hands on the photo conducting medium and the lens assembly. In the case of the lens assembly [1], you may use a dry, soft cloth to wipe off dirt in gentle strokes. However, do not wipe or use alcohol on the photo conducting medium [2].

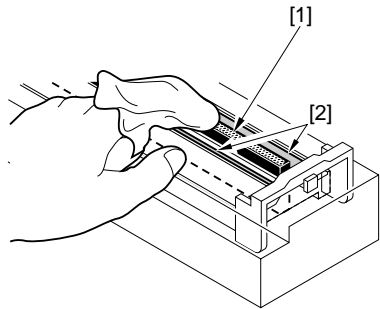

F03-502-12

5.3 Reader Motor

5.3.1 Removing the Reader Motor

- 1) Remove the copyboard cover.
- 2) Remove the copyboard glass retainer (right).
- 3) Remove the rear cover.
- 4) Remove the right lower cover, right rear cover, and right rear upper cover.
- 5) Open the manual feed tray, and detach the left lower cover.
- 6) Remove the drum unit.



When you have removed the drum unit, wrap it in several sheets of copy paper to protect the drum from light.

- 7) Remove the left rear cover and the left upper cover, and detach the rear upper cover.
- 8) Disconnect the connector J13 [2] from the original detection/reader motor drive PCB [1].

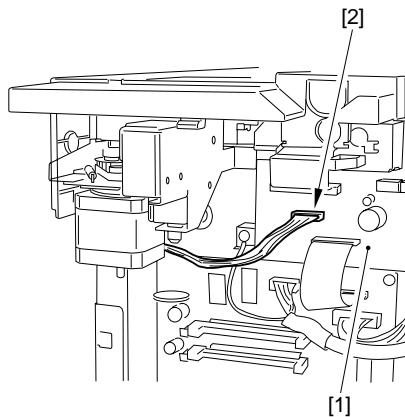

F03-503-01

- 9) Remove the tension spring [3] and the 2 screws [4]; then, detach the reader motor [5].

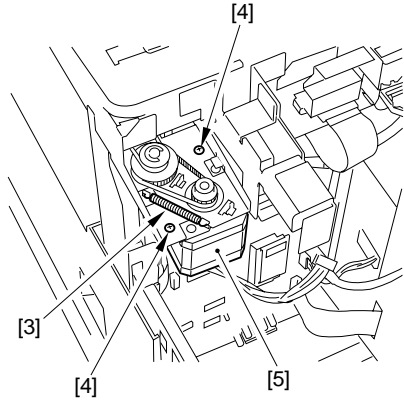

F03-503-02

5.3.2 Points to Note When Mounting the Reader Motor



When mounting the reader motor, be sure to hook the tension spring on the motor and the machine's mounting plate; then, secure it in place with screws. Otherwise, the belt will lack correct tension, leading to malfunction.



When mounting the reader motor, check to be sure that the connector [1] faces the machine; otherwise, the harness of the read motor can interfere with the edge of the plate and suffer a cut.

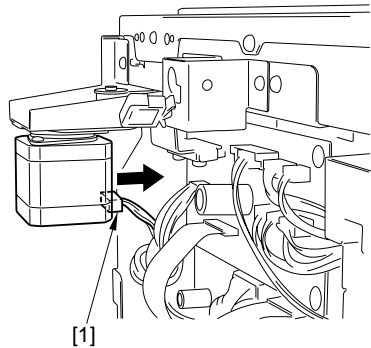

F03-503-03

CHAPTER 4

LASER EXPOSURE SYSTEM

1 Outline of Operation

1.1 Outline

The laser exposure system consists of the following: laser unit, which is the source of laser light; scanner motor, which is equipped with a 6-facet mirror for scanning; and BD PCB, which is used to control the laser light.

The video signals coming from the image processor PCB are sent to the laser driver PCB, which turns on and off the laser diode according to the video signals from the DC controller PCB to generate a modulated laser beam.

The modulated laser beam is converted into a parallel beam of light by a collimator lens and cylindrical lens. After conversion, it is directed to the 6-facet mirror, which is rotating at a specific speed. The laser beam reflected by the lens is then led to the imaging lens and reflecting mirror (arranged in front of the 6-facet mirror) to reach the photosensitive drum.

The laser beam scans the surface of the photosensitive drum at a specific speed as the 6-facet mirror rotates at a specific speed, forming an image on the surface of the drum.

The following are major items of control and methods of control used:

Items	Method
Laser intensity control	Auto control of the laser power (APC control)
Laser scanning Synchronization	Scanning by a semi-conductor laser Control by the BD signal (main scanning direction) Control by the TOP signal (sub scanning direction)
Scanner motor control	Constant speed rotation control

T04-101-01

The following shows the major components of the laser exposure system and its functions; the machine's laser scanning method is based on a 6-facet polygon mirror and a single beam:

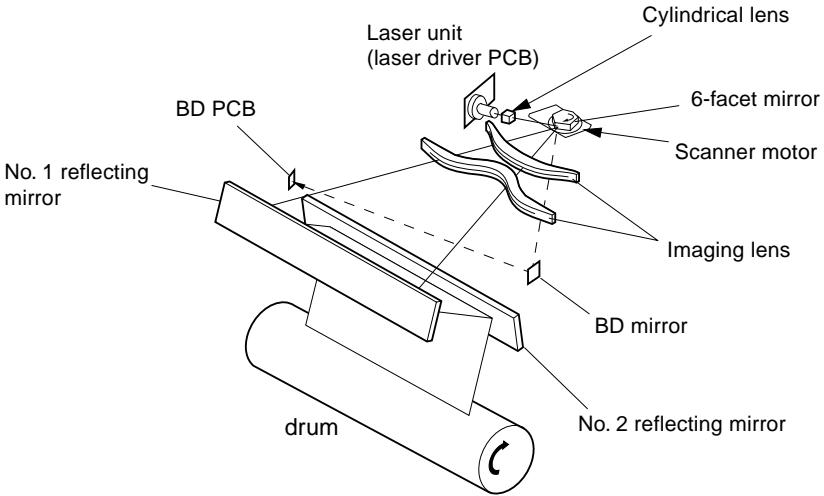

F04-101-01

Component	Description
Laser semi-conductor	Infrared light (about 785 nm), 1-beam
Scanner motor (M102)	DC brushless motor
Polygon mirror	6-faceted
BD mirror/BD PCB	Laser beam detection
Laser driver PCB	Laser emission control
DC controller PCB	Scanner motor rotation control

T04-101-02

1.2 Basic Sequence of Operation (laser exposure system)

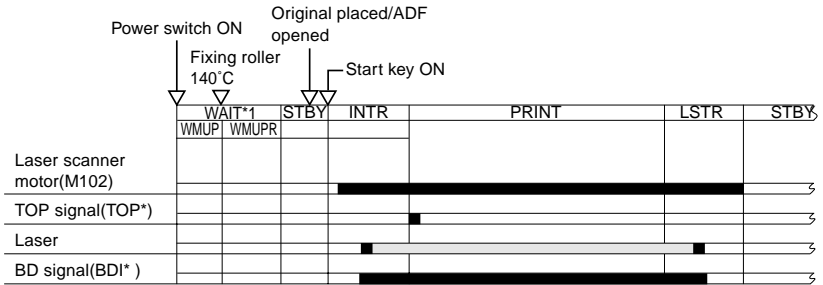

*1: WAIT End Conditions:
 : 25 sec or more passed after supplying power to the fixing assembly and, in addition, the fixing assembly temperature is 150 or higher.
 : 27 sec or more passed after supplying power to the fixing assembly and, in addition, the fixing assembly temperature is 145 or higher.

F04-102-01

2 Generating the Horizontal Signal

2.1 Outline

The laser emission start signal (horizontal sync) is used to direct laser light to the photosensitive drum. The sync signal is generated by the BD PCB based on the laser beam reflected by the BD mirror mounted in the laser beam path.

2.2 Signals Used

- [1] laser emission signal (LONO*). It is generated based on the BD input signal; laser is emitted when it goes '0'.
- [2] BD input signal (BDIN*). It goes '0' upon detection of laser light.
- [3] horizontal sync signal. It is generated based on the BD input signal.
- [4] horizontal synch signal (BDO*). It is used to synchronize the video signals in laser scanning direction in laser scanning direction.
- [5] image data. It is read from image memory with reference to the horizontal sync signal.
- [6] video signal (VDO, VDO*). It is used to form an image on the photosensitive drum.

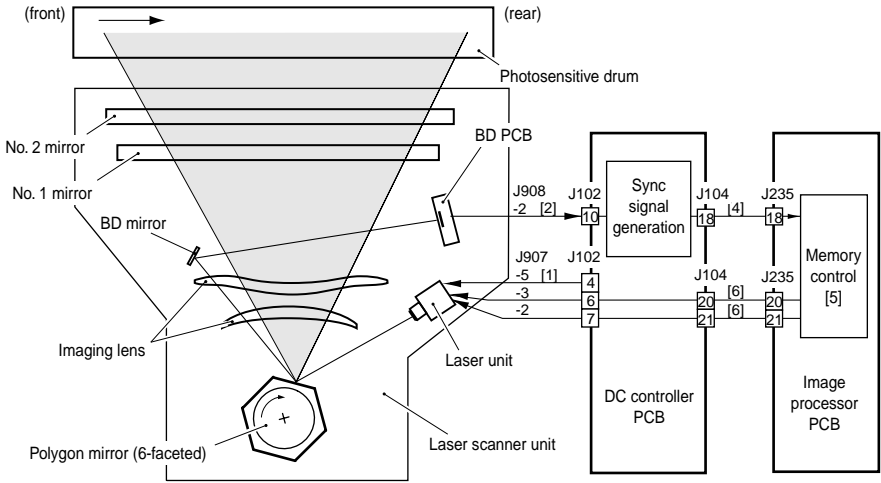

F04-201-01

E100



After laser light is turned on, the BD signal cannot be detected within a specific period of time.

3 Laser Driver Circuit

3.1 Laser Control

The laser driver circuit is used to drive the semiconductor laser according to the video signals from the image processor PCB.

The following items of control relate to the laser driver circuit:

1. Laser emission control
2. Laser power auto control (APC control)

The signals have the following functions:

- [1] laser emission signal. It is generated based on the BD input signal; laser light is emitted when it goes '0'.
- [2] image formation enable signal. It is used to control the output of the video signals; emission of laser light is enabled when it goes '0'.
- [3] video signal: It is a low-amplitude (for noise suppression) drive signal.
- [4] video out signal. It is a low voltage drive signal converted from a video signal. When the image formation enable signal is '0', it turns on/off the laser light.
- [5] registration signal. It generates the TOP signal when paper reaches the registration sensor (PS102) mounted to the front of the registration roller.
- [6] The laser intensity is monitored when laser light is emitted, and a level suited to the intensity of the light is fed back to the laser drive circuit.
- [7] The output is controlled so that the level arriving as feedback and the reference level from the DC controller are identical.
- [8] laser intensity switch signal. It is used to switch the laser intensity between laser start-up and printing. During printing, it is fixed to '0'.

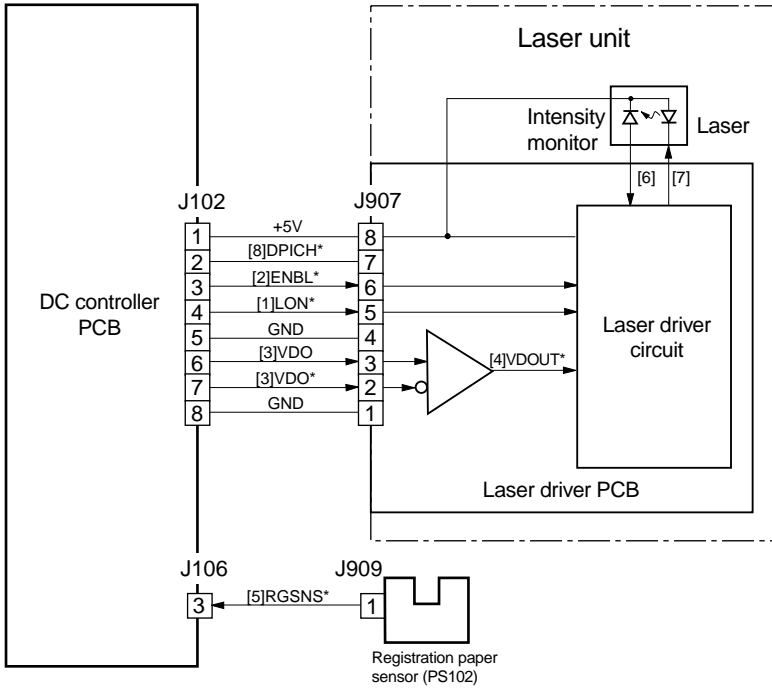

F04-301-01



The laser power is adjusted automatically whenever the laser unit is replaced.

4 Controlling the Scanner Motor

4.1 Outline

The following are items of control related to the scanner motor:

- [1] scanner motor constant speed rotation
- [2] scanner pre-rotation control

4.2 Controlling the Scanner Motor

The scanner motor is controlled as follows:

- [1] When the print signal goes '0', printing is started or continued.
- [2] When the scanner motor acceleration signal goes '0', the scanner motor goes ON.
- [3] The BD input signal goes '0' when laser light is detected.
- [4] The cycle of the BD input signal and the target cycle are compared, and the result is used to control the scanner motor.
- [5] When the scanner motor deceleration signal goes '0', the scanner motor goes off.

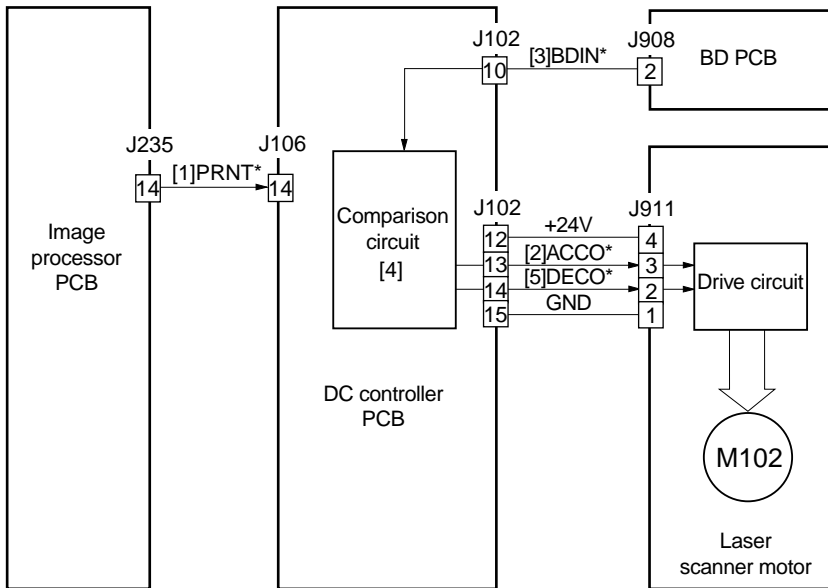

F03-402-01

E100

E100 is indicated under any of the following conditions:

1. When the scanner motor is started up, the BD input signal does not arrive within a specific period of time.
 2. When the scanner motor is started up, the motor rotation is too fast, requiring deceleration; yet, it does not reach a specific revolution within 20 sec.
 3. While the scanner motor is rotating at a constant speed, the cumulative period in which the cycle of the BD input signal exceeds a specific cycle by $\pm 2\%$ is found to be 10 mm (equivalent of printing length).
 4. While the scanner motor is rotating at a constant speed, the cycle of the BD input signal deviates from a specific cycle by $\pm 2\%$ or more.
 5. During the WMUPR period after the power switch has been turned on or the front cover/left cover has been opened/closed, the drum unit is absent.
-

4.3 Scanner Pre-Rotation

The machine sends the scanner pre-rotation command to rotate the scanner motor a specific period of time (depending on when image data is received) in advance of the pickup command (PRINT*) arriving at the DC controller PCB from the image processor PCB, thereby ensuring the correct image leading edge.

The machine sends the scanner pre-rotation command for the following:



For Copying : The ADF detects an original.

The copyboard cover is found to be opened/closed. However, for the first detection after copying, removal of an original will be assumed and, therefore, no scan pre-rotation will be executed.

For Printing : There is no previous image data and, in addition, paper is not being moved and no page is being delivered.

5 Disassembly and Assembly

Here, instructions on how to disassemble/assemble the machine are given together with explanations of its mechanical characteristics; be sure to keep the following in mind when going through the work:

1.  Before starting the work, be sure to disconnect the power plug. Moreover, if you have removed the drum unit, be sure to keep it in a protective bag.
2. Unless otherwise specially indicated, reverse the steps used to disassemble the machine when assembling it.
3. Identify the screws by type (length, diameter) and location.
4. To ensure electrical continuity, the mounting screws used for the grounding wire and arrestors are equipped with toothed washers. Do not leave them out when assembling the machine.
5.  As a rule, do not operate the machine with any of its parts removed.

5.1 Removing the Laser/Scanner Unit

- 1) Remove the fixing assembly. (3.1 of Chapter 7)
- 2) Remove the dust-proof sponge [1].
- 3) Disconnect the 3 connectors [2].
- 4) Remove the 4 screws [3], and detach the laser/scanner assembly [4].

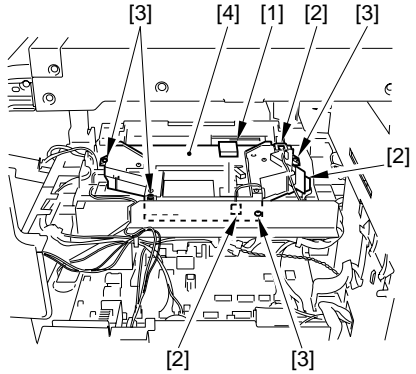

F04-501-01



The inside of heater laser/scanner assembly cannot be adjusted in the field.
Do not disassemble it.

CHAPTER 5

IMAGE FORMATION SYSTEM

1 Outline of Processes

The image formation system has the following functions, and uses the following methods:

Item	roller bias control	Description
Photosensitive drum	OPC (30-mm dia.)	
Drum cleaning	Cleaning blade	
Developing cylinder	20-mm dia.	
Toner	Dry, 1-component, toner projection	
Toner	Negative toner	
Primary charging	AC constant current control (about 1110 μ A; about 860 Hz)	
roller bias control	DC constant voltage control (plain paper mode; about -580 to -650 V)	
Developing bias control	AC constant voltage control (about 1600 Vp-p; about 2200 Hz)	
	DC constant voltage control (plain paper mode; image area, about -360 to -485 V; non-image area, about -495 to -570 V)	
Transfer charging	DC constant voltage control (about 5.76 KV max.; for cleaning bias, about -2.3 KV)	
	DC constant current control (about 5 μ A)	
	voltage level correction control (ATVC)	

T05-101-01

The image formation system consists of the following major components:

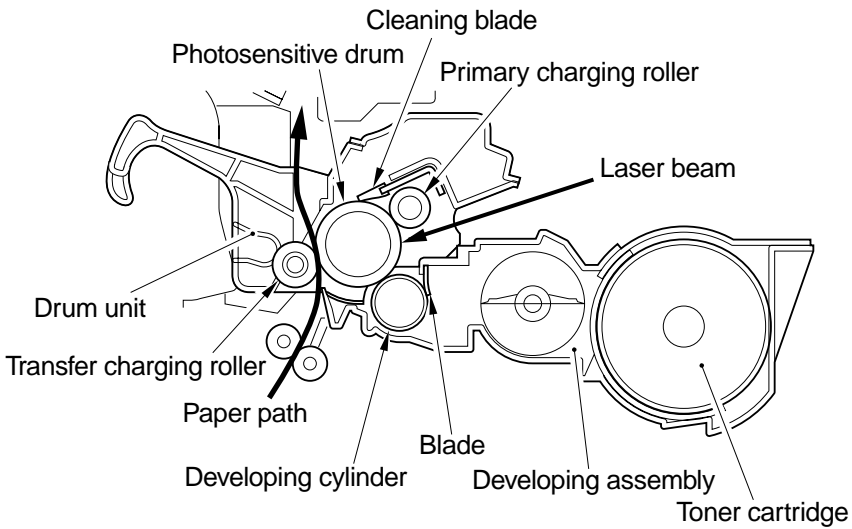

F05-101-01

1.2 Sequence of Operation (image formation system)

- At Power-On

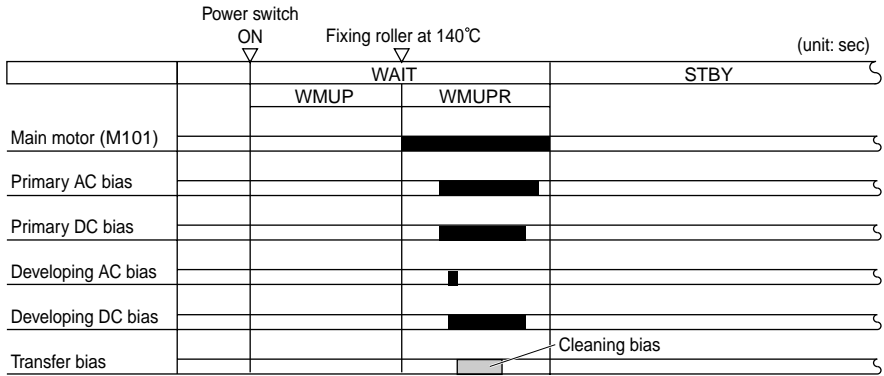

F05-102-01a

- During Printing (1 original, 2 copies, continuous)

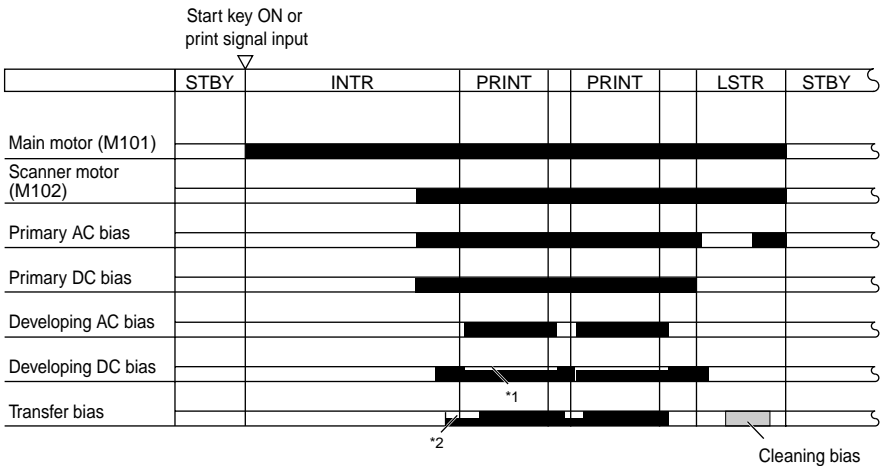

F05-102-01b

2 1 Controlling the Primary Charging Roller Bias

2.1 Outline

The machine uses a charging roller for primary charging (direct charging method), and it applies an AC bias to stabilize the charging in addition to the DC bias.

The following items of control are used in relation to the primary charging control system:

- [1] turning on and of the bias.
- [2] performing constant voltage control for the DC bias.
- [3] performing constant current control for the AC bias.

The primary charging control system is constructed as shown in the following diagram:

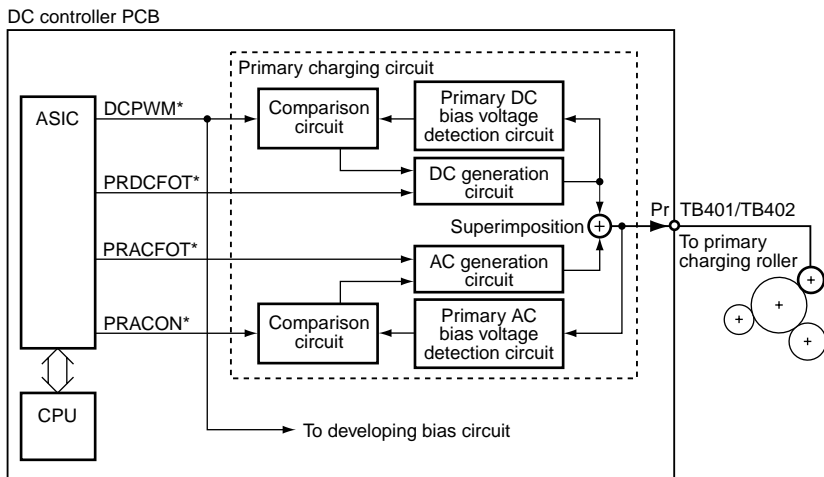

F05-201-01

2.2 Turning On and Off the Bias

The primary charging roller bias is turned on and off as follows:

2.2.1 DC Bias

The DC bias is generated when the primary DC bias drive signal (PRDCFOT*) goes ON. The level of the DC bias is controlled by the primary/developing DC bias output level signal (DCPWM*).

2.2.2 AC Bias

The AC bias is applied when the primary AC bias drive signal (PRACFOT*) goes ON and the primary AC bias ON/OFF signal (PRACON*) goes '0'.

2.3 Bias Constant Voltage/Constant Current Control

The output levels of the DC and AC biases applied to the primary charging roller are controlled as follows:

2.3.1 DC Bias Constant Voltage Control

The output voltage level of the DC bias is detected by the bias voltage detection circuit, and is fed back to the DC generation circuit by way of the comparison circuit. The ASIC on the DC controller PCB varies the pulse width of the primary/developing DC bias output level signal as needed to ensure that the voltage of the DC bias remains at a specific level.

2.3.2 AC Bias Constant Current Control

The output current level of the AC bias is detected by the primary AC bias current circuit, and is fed back to the AC generation circuit by way of a comparison circuit. The AC generation circuit varies the amplitude of the primary AC bias ON/OFF signal as needed to ensure that the current of the AC bias remains at a specific level.

3 Controlling the Developing Bias

3.1 Outline

A DC bias and an AC bias are applied to the developing cylinder, and the developing bias control system has the following functions:

- [1] turning on and off the bias.
- [2] controlling the developing DC bias to a constant voltage level.
- [3] controlling the developing AC bias to a constant voltage level.
- [4] controlling the voltage level of the developing bias.

The system used to control the developing bias control mechanism is constructed as follows:

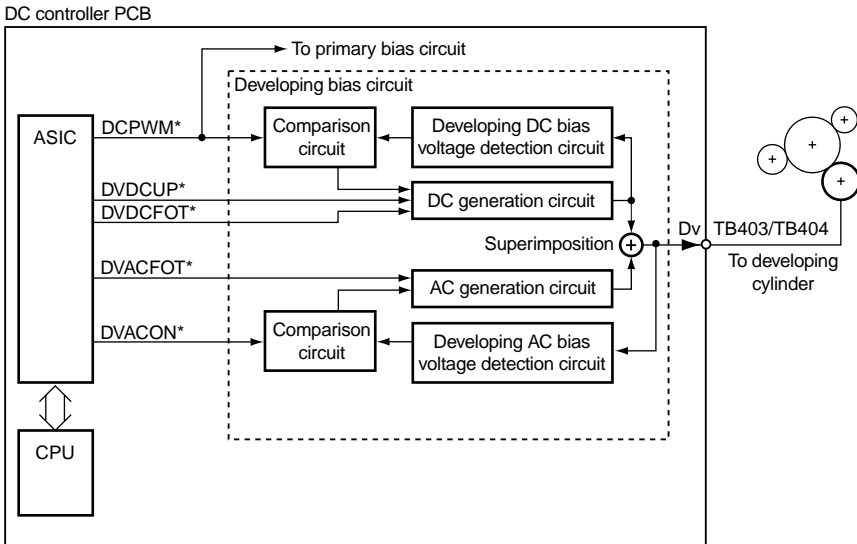

F05-301-01

3.2 Turning On/Off the Bias

The developing bias is turned on/off as follows:

3.2.1 DC Bias

When the developing DC bias drive signal (DVDCFOT*) goes ON, the DC bias is generated. The output level of the DC bias is controlled by the primary/developing DC bias output level signal (DCPWM*).

3.2.2 AC Bias

When the primary AC bias drive signal (DVACFOT*) goes ON and the developing AC bias ON/OFF signal (DVACON*) goes '0', the AC bias is generated.

To prevent stray toner inside the machine, the AC bias is also turned on for image areas and off for non-image areas.

3.3 Controlling the Bias to a Constant Voltage Level

The output level of the DC bias applied to the developing cylinder is controlled as follows:

3.3.1 Controlling the Developing DC Bias to a Constant Level

The output voltage level of the DC bias is detected by the developing DC bias voltage detection circuit, and is fed back to the DC generation circuit by way of the comparison circuit. The ASIC on the DC controller PCB varies the pulse width of the primary/developing bias output level signal as needed to keep the DC bias to a specific voltage level.

3.3.2 Controlling the Developing AC Bias to a Constant Voltage Level

The output voltage level of the AC bias is detected by the developing AC bias voltage detection circuit, and is fed back to the DC generation circuit by way of the comparison circuit. The ASIC on the DC controller PCB varies the amplitude of the developing AC bias ON/OFF signal as needed to ensure that the AC bias is kept to a specific level.

3.4 Controlling the Voltage Level of the Developing DC Bias

The voltage level of the developing DC bias is controlled by varying the pulse width of the primary/developing DC bias output level signal (DCPWM*) to suit such factors as the print density setting.

4 Controlling the Transfer Charging Roller Bias

4.1 Outline

The machine uses a charging roller for charging (direct charging method), and it applies a DC bias to the transfer charging roller.

The machine's transfer charging mechanism is controlled for the following:

- [1] turning on and off the bias.
- [2] controlling the DC bias to a specific voltage/current level.
- [3] correcting the voltage level (ATVC control)

The following shows the system used to control the transfer charging mechanism:

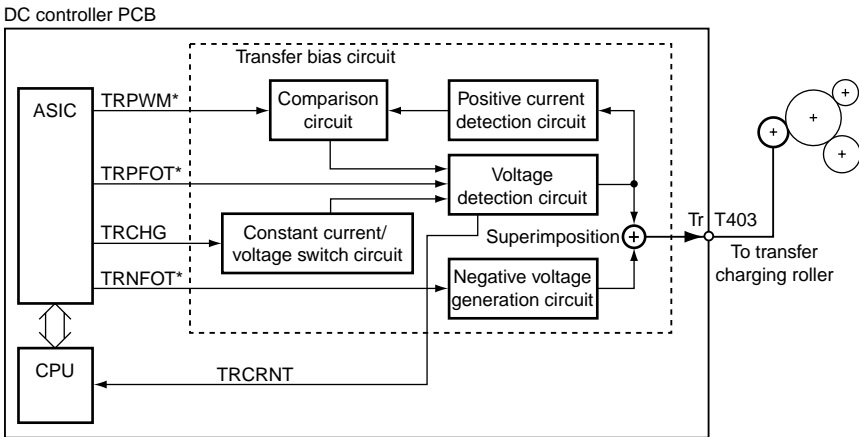

F05-401-01

4.2 Turning On and Off the Bias

The DC bias applied to the transfer charging roller may be a positive DC bias or a negative DC bias, each turned on or off as follows:

4.2.1 Turning On and Off the Positive DC Bias

When the transfer positive DC bias drive signal (TRPFOT*) goes ON and the constant current/voltage switch signal (TRCHG) goes '1', the positive DC bias is generated.

The output level of the DC bias is controlled by the transfer DC bias output level signal (TRPWM*). The positive DC bias is used for image transfer.

4.2.2 Turning On and Off the Negative DC Bias

When the transfer negative DC bias drive signal (TRNFOT*) goes ON, the negative DC bias is generated. The negative DC bias is used for the cleaning of the transfer charging roller.

4.3 Controlling the Bias to a Constant Current /Voltage Level

The output level of the DC bias applied to the transfer charging roller is controlled as follows:

4.3.1 Controlling the DC Bias to a Constant Current Level

The internal resistance of the transfer charging roller changes because of variation among parts and the changes occurring in the environment. When the positive DC bias drive signal (TRPFOT*) goes ON and the constant current/voltage switch signal (TRCHG) goes '0' during initial rotation, a specific level of current is generated, and the CPU measures the voltage level with reference to the transfer charging roller voltage detection signal (TRCRNT) to find out the changes in the internal resistance. It then corrects the DC bias based on the result of detection.

4.3.2 Controlling the DC Bias to a Constant Level

The output level of the DC bias is detected by the developing DC bias voltage detection circuit, and is fed back to the DC generation circuit by way of the comparison circuit. The ASIC on the DC controller PCB then varies the pulse width of the primary/developing DC bias output level signal to ensure that the DC bias is kept to a specific level.

4.4 Correcting the Voltage Level (ATVC control)

To make up for the changes occurring in transfer efficiency caused by changes in the environment or deterioration of the transfer charging roller, the level of application voltage of the transfer bias is controlled automatically during initial rotation and between sheets.

4.5 Controlling the Output According to Operation Mode

4.5.1 Type of Mode

The transfer charging output has the following mode item, each with different output levels:

a. Bias for Image Transfer

It is a bias used to transfer toner images from the photosensitive drum to paper, and is a positive voltage.

b. Cleaning Bias

It is a bias used to return toner from the transfer charging roller to the photosensitive drum, and is a negative voltage applied during initial rotation and last rotation.

c. Sheet-to-Sheet Bias

It is a bias with a lower level, used to prevent toner from adhering to the transfer charging roller in no-image area (between sheets) during continuous printing.

5 Detecting the Presence/Absence of a Cartridge and the Level of Toner

5.1 Outline

A toner level sensor is mounted inside the developing assembly.

The machine uses the output (Ant) of the toner level sensor inside the developing assembly and the output level (Dv) of the developing bias in various detection circuits for A/D conversion.

The CPU checks the difference in level between the cartridge detection signal (TNRCHKD) and the toner detection signal (TNRCHKT) after A/D conversion when the developing bias is applied, thus finding out the presence/absence of cartridge and the level of toner.

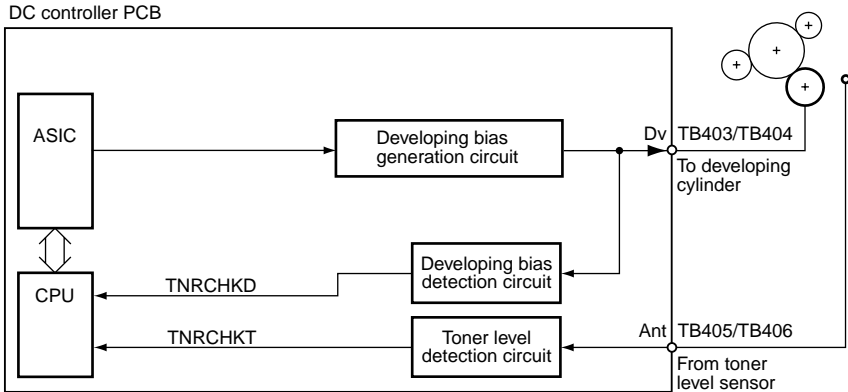

F05-501-01

5.2 Sequence of Detection (level of toner)

The level of toner is detected while the developing bias is applied during initial rotation and warm-up.

The following is the sequence used to detect the level of toner during warm-up:

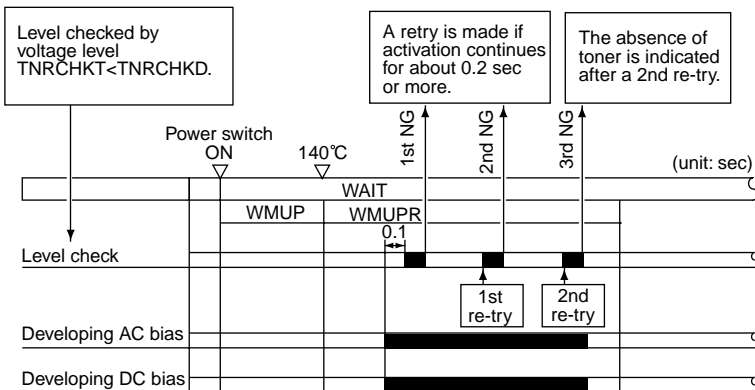

F05-502-01

The following sequence is used to detect the level of toner during initial rotation:

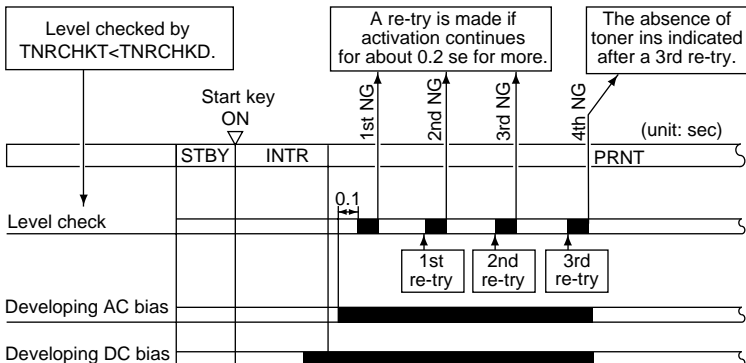

F05-502-02

If the absence of toner is detected, the machine indicates the following message on its LCD: “Toner Empty/Replace Cartridge.”



Memo

If detection is executed 3 times to find out the level of toner at power-on, a wait time of about 40 sec is needed.

6 Monitoring the Waste Toner Case

6.1 Outline

Waste toner is collected by the cleaning blade inside the drum, and is kept in the waste toner assembly.

The waste toner inside the waste toner assembly is constantly stirred by the stirring rod driven by the main motor. The tip of the stirring rod is equipped with a torque limiter unit, which goes ON when the waste toner assembly becomes full and the rod can no longer stir the waste toner; as a result, the sensor lever of the waste toner case full sensor (PS120) will be pushed, causing the machine to know that the waste toner case has become full.

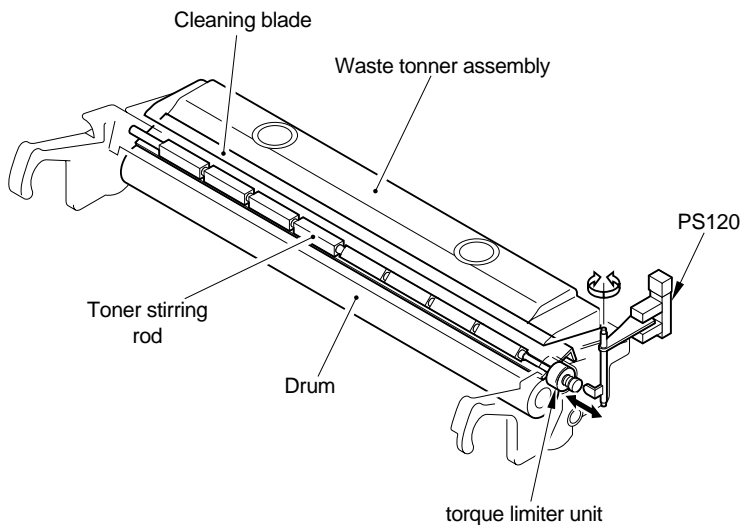

F05-601-01

6.2 Sequence of Operation

The machine monitors the waste toner assembly in 2 steps.

If the waste toner case full detection signal (CFULL*) is '0' for about 1.75 sec or more during initial rotation and during printing, the machine will identify the condition as indicating that the waste toner case is full, and communicate the fact to the image processor PCB, which in turn will indicate the messages 'WASTE TONER FULL' and 'PREPARE A NEW DRUM' in the control panel.

Thereafter, the machine is designed to stop when it has printed 200 page (cumulative). It is reset when initial rotation takes place occurring when the power is turned off and then on or the front cover is opened and then closed.

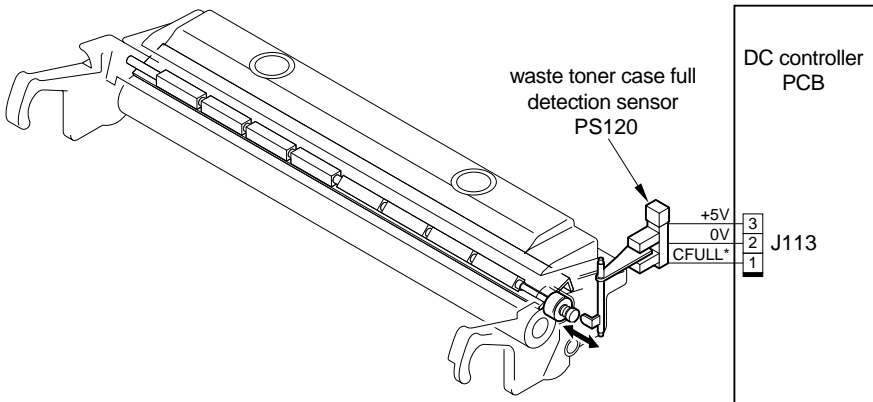



F05-602-01



The waste toner case is capable of storing about 210 g of toner (about 23,000 pages of A4, at 3% print ratio).

7 Disassembly and Assembly

Here, instructions on how to disassemble/assemble the machine are given together with explanations of its mechanical characteristics; be sure to keep the following in mind when going through the work:

1.  Before starting the work, be sure to disconnect the power plug. Moreover, if you have removed the drum unit, be sure to keep it in a protective bag.
2. Unless otherwise specially indicated, reverse the steps used to disassemble the machine when assembling it.
3. Identify the screws by type (length, diameter) and location.
4. To ensure electrical continuity, the mounting screws used for the grounding wire and arrestors are equipped with toothed washers. Do not leave them out when assembling the machine.
5.  As a rule, do not operate the machine with any of its parts removed.

7.1 Photosensitive Drum

7.1.1 Removing the Drum Unit

- 1) Open the front cover.
- 2) Shift down the developing assembly locking lever [1] to unlock the developing assembly.

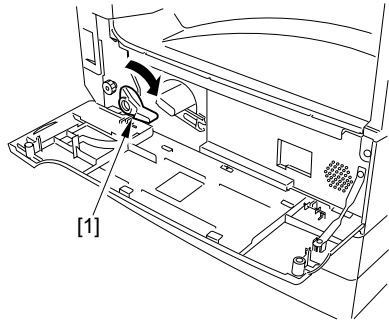

F05-701-01

- 3) Slide out the left cover.
- 4) Holding the grips [2], pull out the drum unit [3].

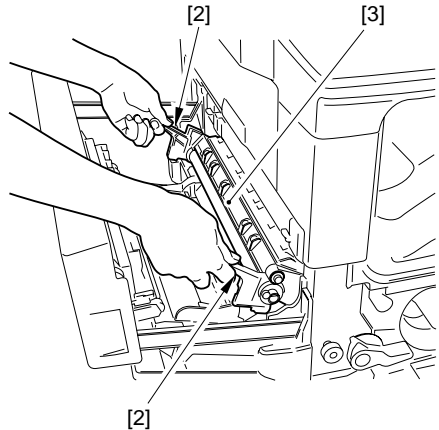

F05-701-02



When removing the drum unit, be sure to hold the grips and take care not to scratch or soil it.

Further, the photosensitive drum is highly sensitive to light. Whenever you have removed it, be sure to protect it against light.

7.1.2 Cleaning the Photosensitive Drum

If the surface of the photosensitive drum is soiled, wipe it with a flannel cloth coated with toner. (Do not use paper, lint-free or otherwise).



Do not dry wipe it or do not use solvent. Moreover, do not use drum cleaning powder.

7.2 Developing Assembly

7.2.1 Removing the Developing Assembly

- 1) Remove the left cover.
- 2) Open the front cover, and shift down the developing assembly locking lever [1]. While pushing on the protrusion of the toner cartridge, turn the grip fully clockwise, and pull out the toner cartridge [2].
- 3) Turn the developing assembly locking lever [3] clock wise to unlock.

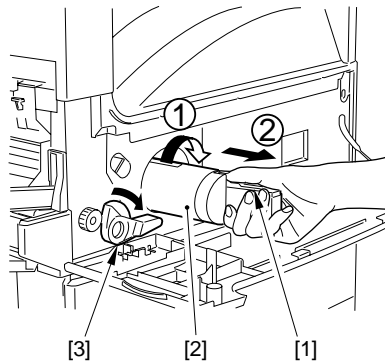

F05-702-01

- 4) Take out the drum unit (7.1.1 in Chapter 5)
- 5) Remove the multifeeder tray. (5.2.1 in Chapter 6)
- 6) Remove the two screws [4], and detach the shaft guide [5].

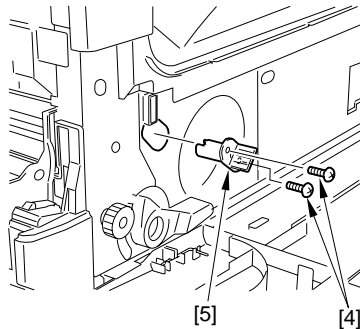

F05-702-02

- 7) Holding the grips [6], slowly pull out the developing assembly [7].

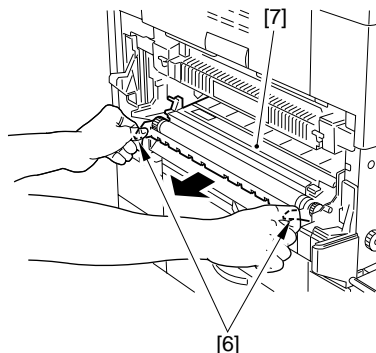

F05-702-03



1. When you pull out the developing assembly, the lever [8] at the rear of the developing assembly will come into contact with the plate [9] of the fixing assembly. Be sure to work slowly and with care. When it comes into contact, try pushing the grips down slightly as you pull on them.
2. When you slide in the developing assembly, push it in so that it will slide along the rails. When the lever [8] comes into contact with the plate [9] of the fixing assembly, try to lift it slightly as you push it in.
3. When you are mounting the developing assembly, check to make sure that the shaft [10] of the developing sleeve is in contact with the electrode [11].
4. When mounting the developing assembly, be sure to fit the positioning pin [12] (at its rear) into the bushing [13].

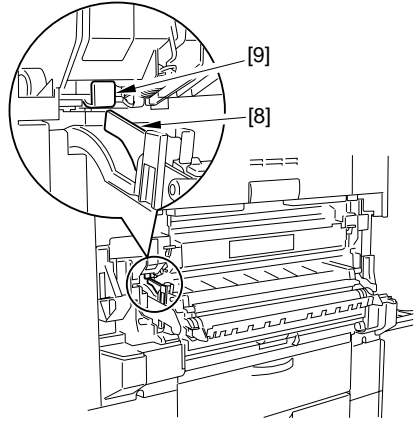

F05-702-04

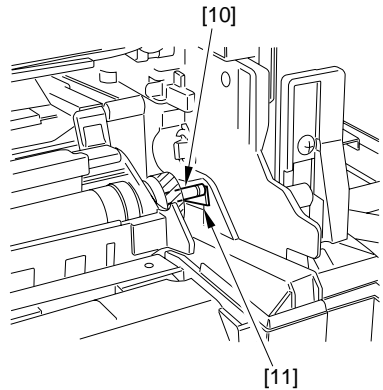

F05-702-05

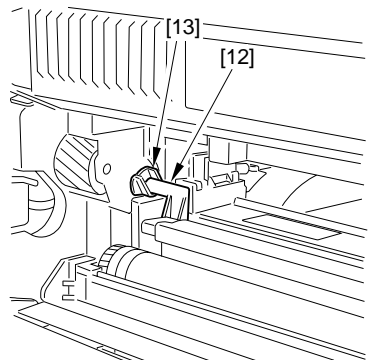

F05-702-06

7.3 Transfer Roller

7.3.1 Removing the Transfer Roller

- 1) Slide out the left cover to detach.
- 2) Holding the shaft assembly [1], remove the transfer charging roller [2].

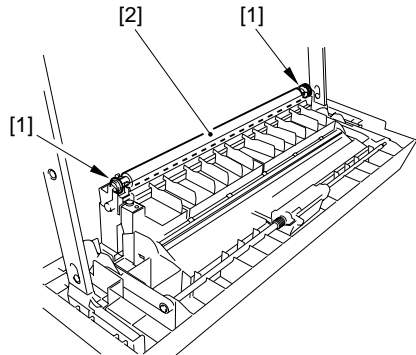

F05-703-01



-
1. Do not hold the roller portion of the transfer charging roller. When cleaning it, take care not to touch the roller surface or leave solvents or oils.
 2. To clean the transfer charging roller, use lint-free paper (while making sure not to leave paper lint) to dry wipe it. Do not use water or solvent.
 3. If white spots occur in the print images or soiling occurs on the back and, in addition, if the dirt of paper lint or toner cannot be removed using lint-free paper, or the roller is deformed, replace the transfer charging roller.
-

CHAPTER 6

PICKUP/FEEDING SYSTEM

1 Outline

1.1 Specifications and Constructions

This chapter explains the pickup mechanism using the 1-cassette (built into the machine) type. In the case of the 2-cassette type, refer to “Cassette Unit” in Chapter 9, as it will basically be a configuration based on the 1-cassette type to which a 1-cassette unit (accessory) is installed.

The pickup/feeding system has the following functions and uses the following methods:

Item	Description
Paper feed reference	Center
Paper stack	
Multifeeder	10 mm in height
Tray AB:	Plain paper, recycled paper, colored paper 100 sheets if A4R, A4, B5, B5R, A5, A5R (80 g/m ²) 50 sheets if A3, B4 (80 g/m ²) 50 sheets if transparency, thick paper (90 to 128 g/m ²) 10 sheets if envelope
Inch:	Plain paper, recycled paper, colored paper 100 sheets if LTR, LTRR, STMT, STMTR (80 g/m ²) 50 sheets if transparency, thick paper (90 to 128 g/m ²) 10 sheets if envelope 50 sheets if 11x17 (279.4x431.8 mm), LGL
Cassette	25 mm in depth (250 sheets max. of 80 g/m ²)
Paper size setting	Cassette: by user Manual feed tray: by user
Related user mode	Paper size settings for manual feed tray

T06-101-01

1.2 Arrangement of Major Rollers and Sensors

The arrangement of the major rollers and sensors of the pickup/feeding system is as follows:

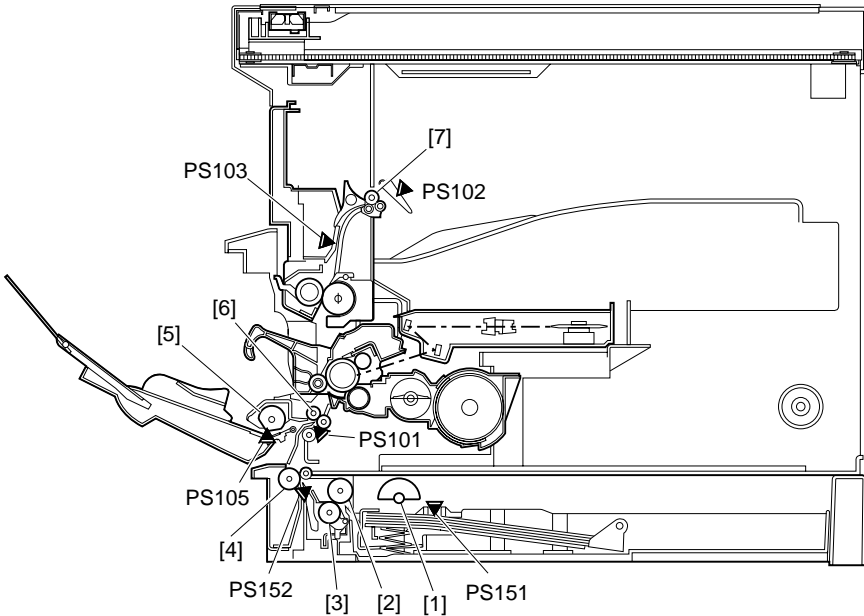

F06-102-01

Notation	Name
PS101	Registration paper sensor
PS102	Paper full sensor
PS103	Delivery sensor
PS105	Multifeeder paper sensor
PS151	Cassette paper sensor
PS152	Retry sensor
[1]	Pickup roller
[2]	Feeding roller
[3]	Separation roller
[4]	Vertical path roller
[5]	Manual feed pickup roller
[6]	Registration roller
[7]	Delivery roller

T06-102-01

2 Controlling the Pickup Assembly

2.1 Controlling the Pickup from the Cassette

2.1.1 Outline

The paper picked up from the cassette is moved as far as the registration roller assembly by the work of the vertical path roller driven by the main motor. When the paper reaches the registration roller, the registration roller is at rest, causing the leading edge of the paper to butt against it to form an arch.

The DC controller PCB turns on the registration clutch (CL101) at specific timing to transmit the drive of the main motor to the registration roller, thereby moving the paper ahead. The paper reaches the delivery tray after moving through the transfer, separation, and fixing/delivery assemblies.

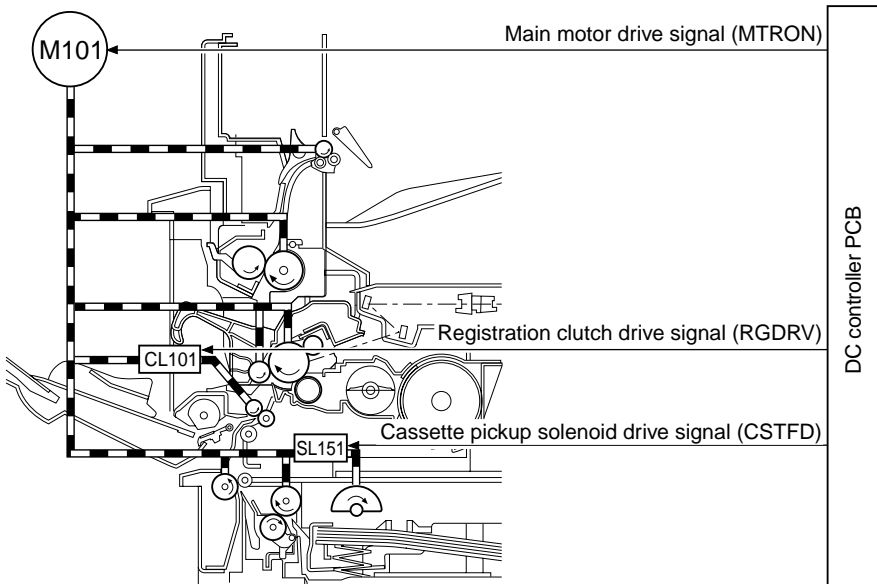

F06-201-01

2.1.2 Pickup form the Cassette

The rotation of the pickup roller is controlled by the pickup roller drive gear used to transmit the drive of the main motor (M101) to the gear of the pickup drive shaft and the cassette pickup solenoid (SL101).

When the main motor rotates, the drive relay gear starts to rotate in response. At this time, the area of the pickup roller gear without a tooth is located at the relay gear; the absence of engagement between both gears prevents the drive from reaching the pickup roller shaft.

1. The DC controller PCB generates the cassette pickup solenoid drive signal (CSTFD) to turn on the solenoid; as a result, the control arm pushes the cam to rotate the pickup roller drive gear slightly.

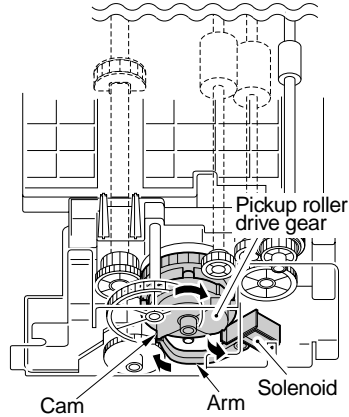

F06-201-02

2. When the pickup roller drive gear and the pickup roller shaft gear engage, the drive reaches the pickup roller shaft gear to rotate the pickup roller.

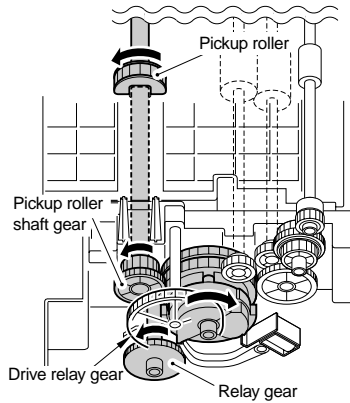

F06-201-03

3. When the feeding roller drive gear and the feeding roller shaft gear engage, the drive reaches the feeding roller gear to rotate the feeding roller.
4. When the pickup roller makes a single rotation, the area of the pickup roller drive without a tooth will be located at the relay gear, preventing the drive of the main motor from reaching the pickup roller and the feeding roller, stopping both rollers.
5. After pickup, the paper is moved under the vertical path roller and then to the registration roller assembly.

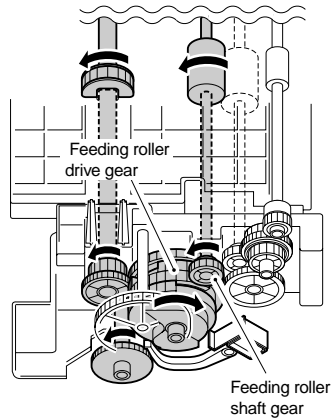

F06-201-04

2.1.3 Pickup Retry

If paper is not picked up despite the rotation of the pickup roller, the machine will execute a retry operation. The DC controller PCB keeps count of the time starting when the cassette pickup solenoid (SL151) goes ON. If the retry sensor (PS152) does not detect the leading edge of paper within a specific period of time, the machine will turn on the cassette pickup solenoid once again for a pickup retry.

If the retry sensor does not detect the leading edge of paper within a specific period of time after executing a retry pickup twice, the machine will identify the condition as a jam, and will indicate a jam message on the LCD in the control panel.

- Sequence of Operation for a Pickup Retry

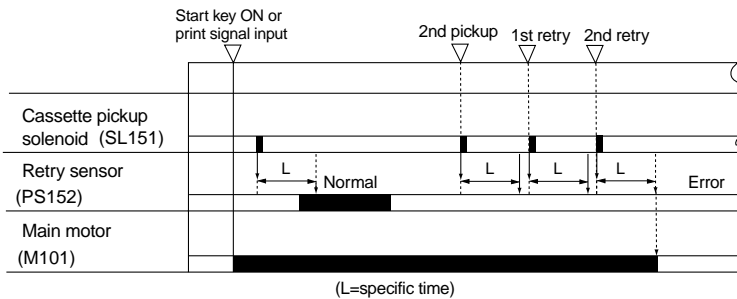

F06-201-05

2.1.4 Detecting the Size of Paper in the Cassette

The size of paper inside the cassette is detected by the DC controller PCB in relation to the position of the paper size lever of the cassette set by the user.

When the cassette is fitted to the machine, the paper size lever pushes the paper size switch (SW105) found inside the machine, enabling the machine to detect the presence/absence of a cassette and the size of paper inside it.

The paper size switches are arranged as follows, and the combination of push switches pressed by the paper size lever is used to detect the size of paper.

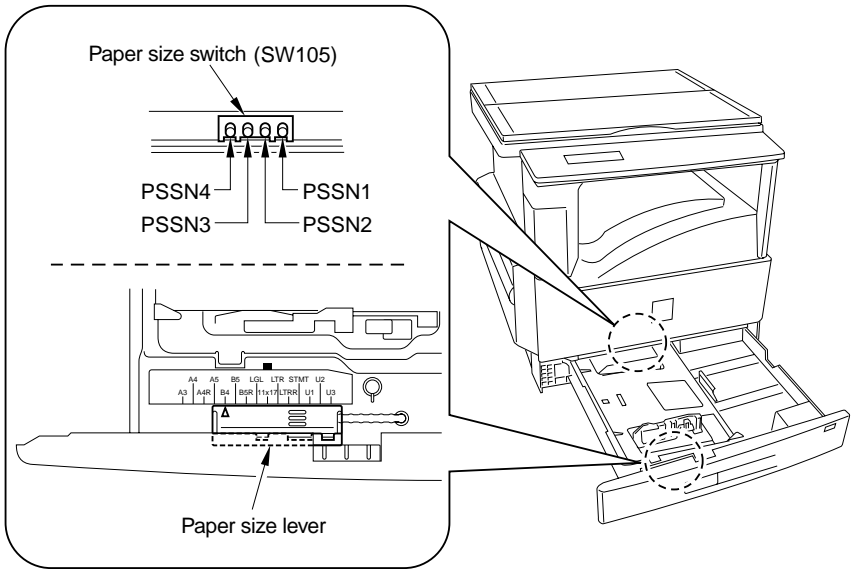

F06-201-06

	A3	A4	A4R	A5	B4	B5	B5R	LGL	11x17	LTR	LTRR	STMT	U1*	U2*	U3*
PSSN 1	●	○	●	○	○	●	●	○	●	●	●	●	○	○	○
PSSN 2	○	●	○	●	○	○	●	●	○	●	●	●	●	○	○
PSSN 3	○	○	●	○	●	○	○	●	●	○	●	●	●	●	○
PSSN 4	○	○	○	●	○	●	○	○	●	●	○	●	●	●	●

● : push switch is pressed.

○ : push switch is not pressed.

* : not used.

T06-201-01

2.2 Controlling the Pickup from the Multifeeder Tray

2.2.1 Outline

The manual feed pickup operation is designed to enable continuous pickup of sheets of paper stacked in the multifeeder tray.

The paper in the tray is held up by the holding plate, and is forced against the manual feed pickup roller. The drive of the manual pickup roller comes from the main motor (M101) by way of the manual pickup solenoid (SL101) and a gear.

The manual pickup roller and the manual pickup separation pad make sure that only one sheet of paper is picked and sent to the registration roller.

This series of operations is performed for each single sheet of paper.

The size of paper placed in the multifeeder tray is as selected by the user in the control panel.

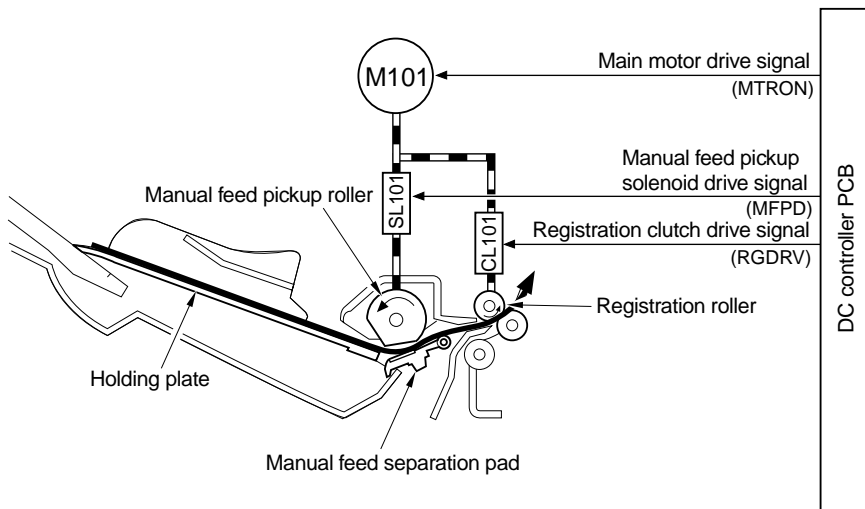

F06-202-01

2.2.2 Pickup from the Multifeeder Tray

a. Movement of the Holding Plate

While in standby, the holding plate is at the bottom supported by the cams mounted to the front and rear of the manual feed pickup roller shaft.

When the pickup roller rotates, the cams start to rotate in response, causing the holding plate to move up so that the paper placed in the multifeeder comes into contact with the pickup roller.

The separation pad is mounted opposite the pickup roller, serving to separate one sheet of paper and sending it to the inside of the machine.

b. Multifeeder Tray Pickup Drive Mechanism

The manual feed pickup roller rotates by the drive of the main motor reaching the gear of the manual feed tray pickup drive assembly. The timing at which paper is picked up is controlled by the manual feed pickup solenoid drive signal (MFPD) from the DC controller PCB.

As soon as the main motor starts to rotate, its drive is transmitted to the pickup drive transmission gear.

When the DC controller PCB generates the manual feed pickup solenoid drive signal (MFPD) and the solenoid goes ON as a result, the stopper will be released so that the pickup roller stops to rotate.

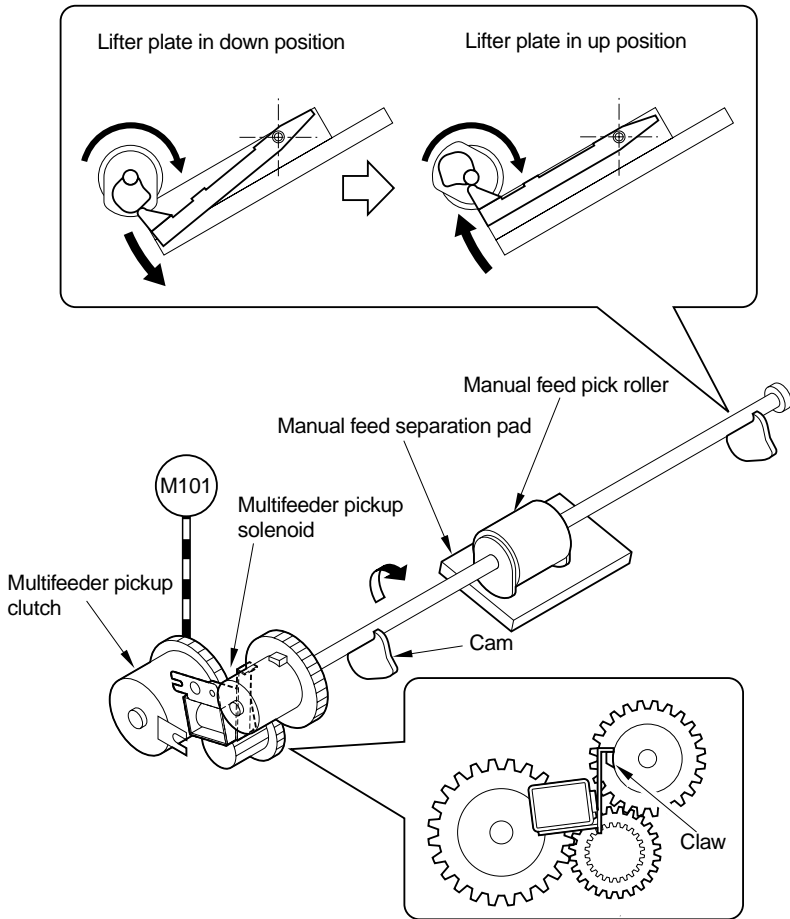

F06-202-02

2.2.3 Multifeeder Retry Operation

If paper is not picked up when the manual pick roller has rotated, the machine will execute a retry pickup operation.

The DC controller PCB keeps count of time starting when the manual feed pickup solenoid goes ON. If the registration paper sensor (PS101) does not detect the leading edge of paper within a specific period of time, it turns on the pickup solenoid once again for a pickup operation. If the registration paper sensor still does not detect the leading edge of paper within a specific period of time after a second retry operation, the machine will execute a retry pickup operation once again. If paper still does not reach the registration paper sensor after a 3rd retry pickup operation, the machine will identify the condition as a jam, and will indicate a jam message on the LCD in the control panel.

2.2.4 Setting the Paper Size for the Multifeeder Tray (user mode)

The multifeeder tray may be set to a specific paper size, selected according to how it is used:

1. If a different size is used each time paper is supplied (default),
Choose 'OFF' in user mode: 1 COMMON SETTINGS>4 USE STACK BYPASS.
2. If the same size is to be used at all times,
Choose 'ON' in user mode, and select a specific size using the cursor key: 1 COMMON SETTINGS>4 USE STACK BYPASS.

If printing is executed while the selected size differs from the size of paper placed in the multifeeder tray, the machine will indicate a message at the end of printing on the 1st sheet, and will stop printing operation.

3 Controlling the Registration Roller

3.1 Detecting the Leading Edge of Paper

The paper coming from the pickup assembly is moved farther to the transfer assembly when the registration clutch (CL101) goes ON and the registration roller starts to rotate as a result.

The DC controller PCB sends the vertical sync signal (TOP*) to the image processor PCB when the registration paper sensor (PS101) detects the leading edge of paper.

A specific period of time after the image processor PCB receives the TOP* signal, video signals (VDO*, VDO) are sent so that the leading edge of the image on the photosensitive drum and the leading edge of paper will match. The paper is then moved through the transfer, separation, and fixing assemblies to reach the delivery tray.

The original leading edge margin adjustment volume (VR101) mounted on the DC controller PCB may be used to change the timing at which the registration clutch (CL101) goes ON, thereby increasing or decreasing the leading edge margin to suit the original.

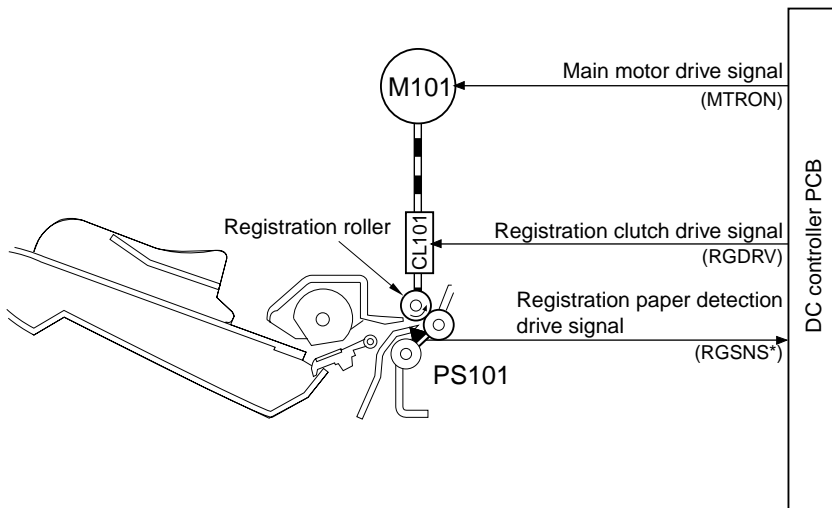

F06-301-01

4 Detecting Jams

4.1 Outline

The machine is equipped with 3 jam sensors used to motor the movement of paper. In addition to these sensors, the machine is also provided with sensors to find out the presence/absence of paper in the cassette and manual feed tray (1 pc. each).

The presence/absence of paper or of a jam is checked at such times as programmed in advance in the CPU of the DC controller PCB and in relation to the presence/absence of paper over a specific sensor at a given time. If the machine detects a jam, it will turn off the main motor (M101), and will indicate a jam message in the control panel.



Memo

If a jam occurs while the machine is in copy mode, all images stored in memory will be lost, requiring the machine to start with the original for which a jam has occurred.

The following are the sensors used to monitor the movement of paper:

Notation	Name	Delay jam	Stationary jam	Stationary jam at power-on
PS101	Registration paper sensor	Present	Present	Present
PS102	Paper full sensor	Absent	Absent	Absent
PS103	Delivery sensor	Present	Present	Present
PS105	Multifeeder paper sensor	Absent	Absent	Absent
PS151	Cassette paper sensor	Absent	Absent	Absent
PS152	Retry sensor	Present	Present	Present

T06-401-01



You can check the condition of a sensor (presence/absence of paper or jam detection) by making the following selections; service mode>test mode>6: FACULTY TEST>6-3: SENSOR.

4.2 Sequence of Jam Detection

4.2.1 Delay Jam

a. Cassette Pickup Assembly

The machine will identify the following condition as a cassette pickup assembly delay jam: after the cassette pickup solenoid goes ON, the leading edge of paper does not reach the retry sensor within a specific period of time.

Pickup assembly	Motor	Sensor
Cassette	Cassette pickup solenoid (SL151)	Retry sensor (PS152)

T05-402-01

b. Other Delay Jams

A check is made for jams other than a cassette pickup assembly delay jam as follows:

The machine will identify the following condition as a delay jam: the time it takes for paper to move from the sensor N-1 to the delay jam sensor N in question is controlled in relation to the number of clock pulses from the main motor; the delay jam sensor N in question does not go ON within a specific period of time after the sensor N-1 goes ON.

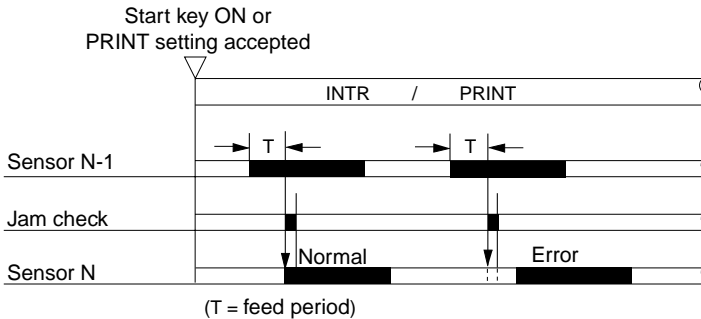

F06-402-01

Notation	Name	Delay jam
PS101	Registration sensor	Present
PS102	Paper full sensor	Absent
PS103	Delivery sensor	Present
PS105	Multifeeder paper sensor	Absent
PS151	Cassette paper sensor	Absent

T06-402-02

4.2.2 Stationary Jams

a. Ordinary Stationary Jam

The machine checks for a stationary jam as follows:

The machine will identify the following condition as a stationary jam: the time it takes for paper to move from the stationary jam sensor N in question to the next sensor is controlled in relation to the number of clock pulses from the main motor; the sensor N does not go OFF within a specific period of time after the sensor N goes ON.

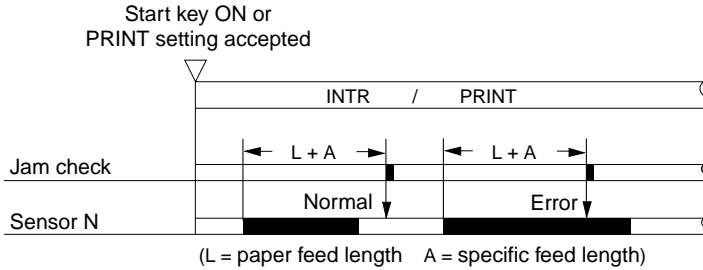

F06-402-02

b. Stationary Jam at Power-On

The machine will identify the following condition as a stationary jam: the delivery sensor (PS103) goes ON 1.4 sec after the initial rotation (INTR), or the registration sensor (PS101) goes ON at the start of initial rotation (INTR).

4.2.3 Cover Open Jam

If the front cover, left cover or left lower cover is opened while paper exits in the paper path, the machine will identify the condition as a cover open jam.

4.2.4 Jam History

The machine keeps a record of jams that have occurred. You can generate a service report to check the history or clear the history.



To indicate jam data,

Make the following selections in service mode: #10 REPORT > 07 JAM/
ERR LOG REPORT

To clear the jam history,



Make the following selections in service mode: #12 CLEAR > REPORT >
JAM.

The machine retains the following data at time of a jam, automatically using them after removal of the jam:

- remaining number of prints to make
- printing mode

5 Disassembly and Assembly

Here, instructions on how to disassemble/assemble the machine are given together with explanations of its mechanical characteristics; be sure to keep the following in mind when going through the work:

1.  Before starting the work, be sure to disconnect the power plug. Moreover, if you have removed the drum unit, be sure to keep it in a protective bag.
2. Unless otherwise specially indicated, reverse the steps used to disassemble the machine when assembling it.
3. Identify the screws by type (length, diameter) and location.
4. To ensure electrical continuity, the mounting screws used for the grounding wire and arrestors are equipped with toothed washers. Do not leave them out when assembling the machine.
5.  As a rule, do not operate the machine with any of its parts removed.

5.1 Cassette Pickup Assembly

5.1.1 Remove the Cassette Pickup Assembly

- 1) Remove the front cover.
- 2) Slide out the cassette.
- 3) Remove the 4 screws [1], and detach the 2 fixing plate [2].

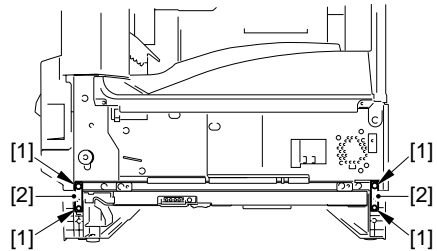

F06-501-01

- 4) Remove the rear cover and the cassette rear cover.
- 5) Remove the 4 screws [3], and detach the 2 fixing plate [4].
- 6) Remove the 2 screws (2/ washer) [5], and detach the leaf spring [6].
- 7) Disconnect the connector [7].

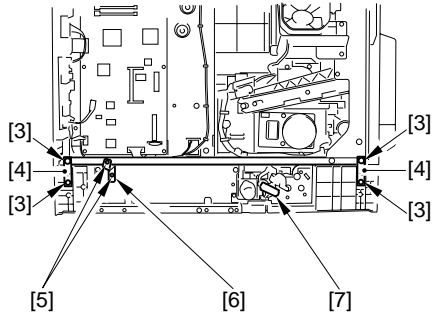

F06-501-02

8) Holding the cassette unit [9] as shown, separate it from the machine [8].

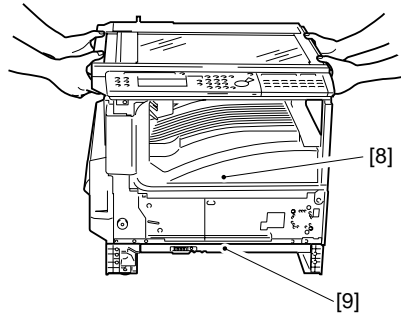

F06-501-03

9) Spread the support assembly [10] of the front/rear of the left lower cover with a little force, and detach the left lower cover [11].

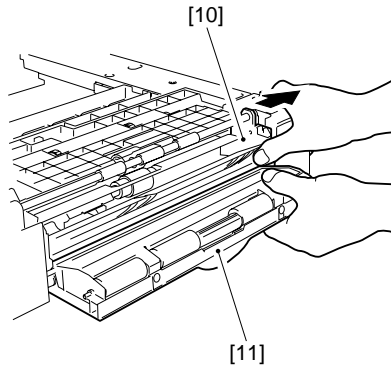

F06-501-04

10) Remove the 5 screws [12] and the screw (w/ washer) [13].

11) Disconnect the 3 connectors [14], and detach the cassette pickup assembly [15].

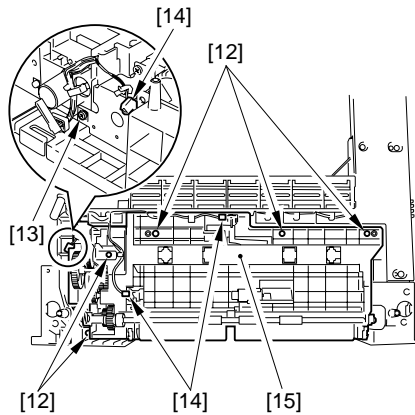

F06-501-05



When mounting, make sure that the grounding plate [15] is on the outside as shown.

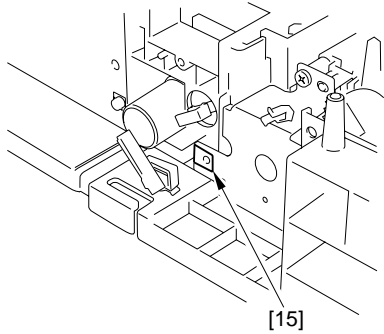

F06-501-06

5.1.2 Removing the Cassette Pickup Roller

- 1) Slide out the cassette.
- 2) Open the left lower cover.
- 3) Holding the pickup roller assembly [1] so that it faces downward, insert a screwdriver [2] or the like from the left side of the machine.
- 4) Grab the pickup roller [3], and detach it.

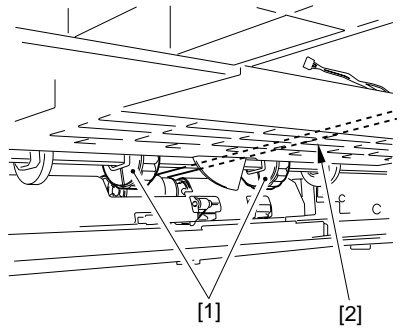

F06-501-07

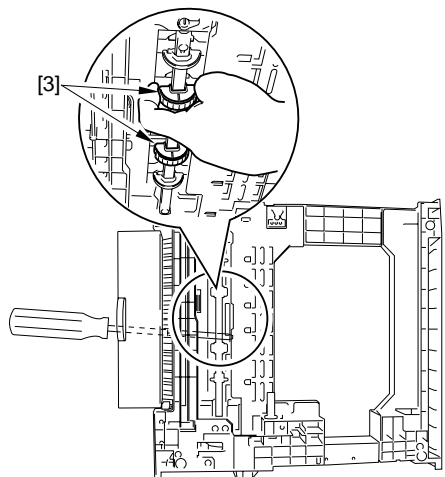

F06-501-08

5.1.3 Removing the Feeding/Separation Roller

- 1) Slide out the cassette.
- 2) Open the left lower cover.
- 3) Push down the separation roller [1] as shown; then, pick the claw [2] of the roller collar, and detach the separation roller [1] and the feeding roller [3].

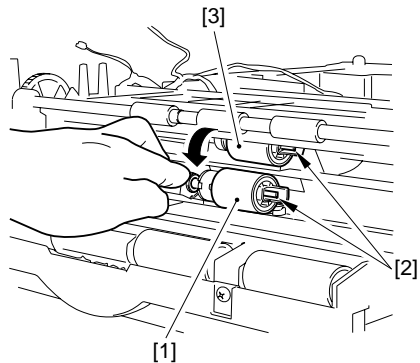

F06-501-09

5.1.4 Removing the Cassette Pickup Solenoid

- 1) Remove the cassette pickup assembly (5.1.1 in Chapter6).
- 2) Free the harness [1] from the harness guide [2], and remove the screw [3]; then, detach the cassette pickup solenoid [4].

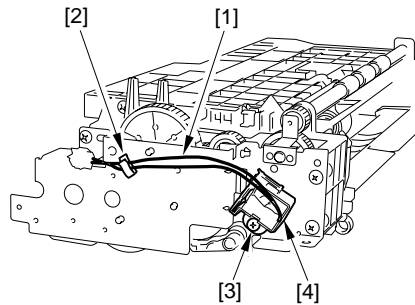

F06-501-10

5.1.5 Removing the Paper Size Detecting Switch

- 1) Remove the screw [1], and slide out the paper size detecting switch [2].
- 2) Disconnect the connector [3], and remove the paper size detecting switch [2].

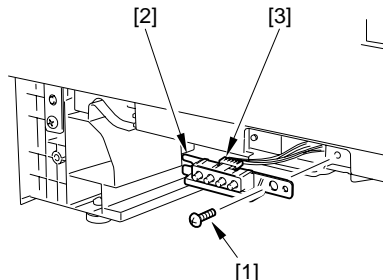

F06-501-11

5.1.6 Removing the Cassette Paper Sensor

- 1) Remove the cassette pickup assembly (5.1.1 in Chapter6).
- 2) Disconnect the connector [1], and detach the cassette paper sensor [2].

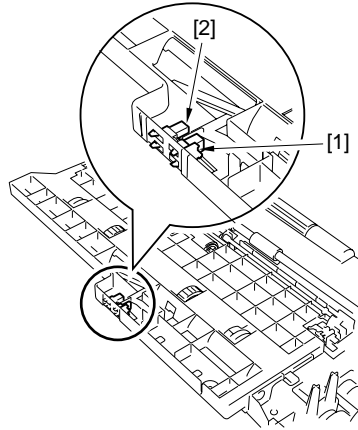

F06-501-12

5.1.7 Removing the Retry Sensor

- 1) Remove the cassette pickup assembly (5.1.1 in Chapter6).
- 2) Disconnect the connector [1], and remove the retry sensor [2].

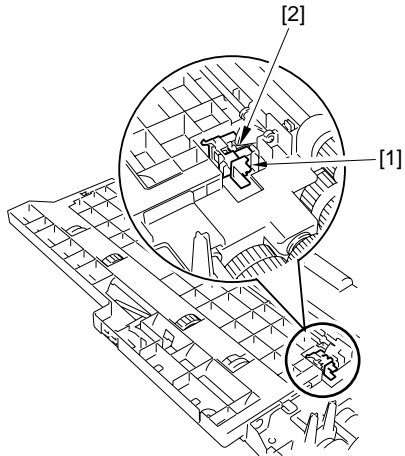

F06-501-13

5.1.8 Removing the Pickup Motor (iR2000 only)

See to 4.4.1 Removing the Pickup Motor in Chapter9.

5.2 Multifeeder Tray Assembly

5.2.1 Removing the Multifeeder Tray

- 1) Remove the left cover.
- 2) Free the 2 hooks [1], and detach the multifeeder tray [2].

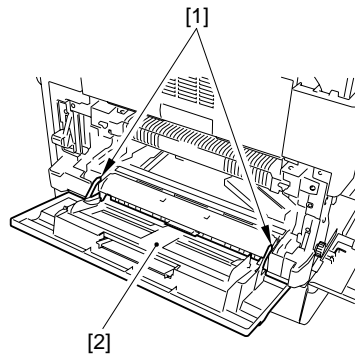

F06-502-01



After mounting the multifeeder tray, check to make sure that the holding plate [4] is pushed down by the manual feed pickup roller cam [3].

· If the holding plate is up, push down the holding plate and, while doing so, rotate the manual feed pickup roller [5] using lint-free paper (so as not to come into direct contact with its surface) until the holding plate is in low position (by the manual feed roller cam).

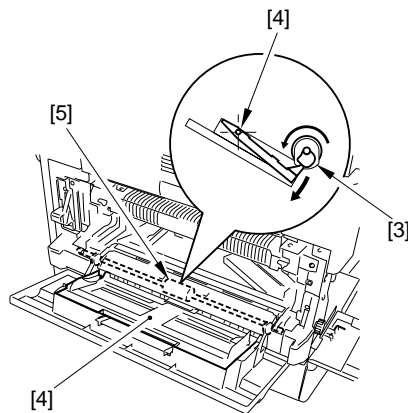

F06-502-02

5.2.2 Removing the Manual feed Pickup Roller

- 1) Remove the drum unit.
- 2) Remove the developing assembly (7.2.1 in Chapter5).
- 3) Remove the multifeder tray.
- 4) Remove the 2 stepped screws [1] using a screwdriver; then, keeping your hands as shown, detach the pickup guide assembly [2] by lifting it upward to the front.

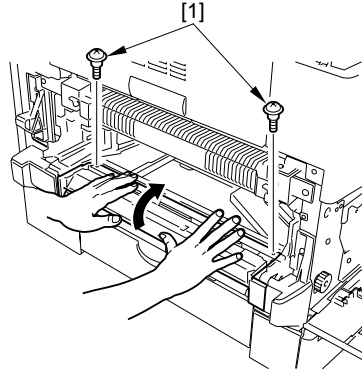

F06-502-03

- 5) Remove the manual feed pickup roller [3].



When Mounting
After mounting the manual feed pickup roller, rotate the manual feed pickup roller until it stops, and check to make sure that the cam [4] is as shown.

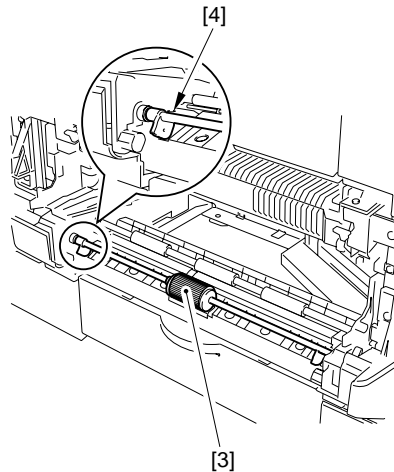

F06-502-04

5.2.3 Removing the Separation Pad

- 1) Remove the manual feed pickup roller.
- 2) Remove the separation pad [1].

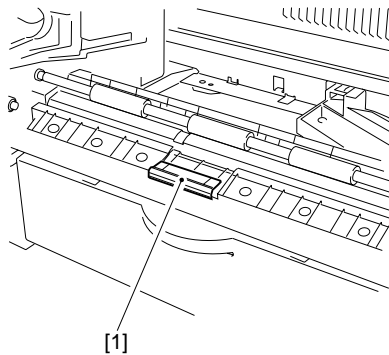

F06-502-05

5.2.4 Removing the Mulfefeeder Paper Sensor

- 1) Remove the left cover and the mulfefeeder tray.
- 2) Remove the 2 screws [1], and detach the cover [2].

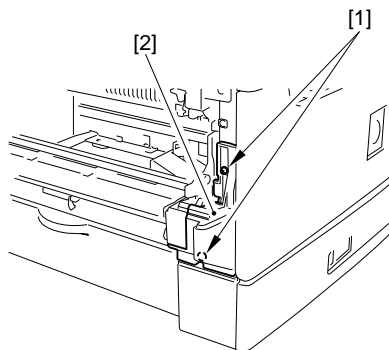

F06-502-06

- 3) Disconnect the connector [3], and free the sensor hook [4]; then, detach the mulfefeeder paper sensor [5].

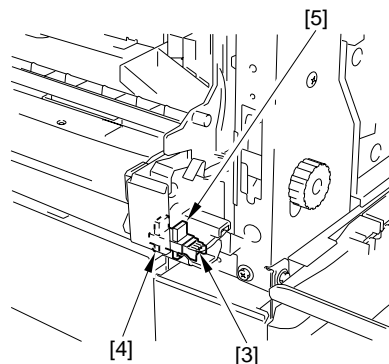

F06-502-07

5.2.5 Removing the Multifeeder Pickup Solenoid

- 1) Remove the rear cover and the left rear cover.
- 2) Remove the screw [1], and disconnect the connector [2].
- 3) Remove the multifeeder pickup solenoid [3].

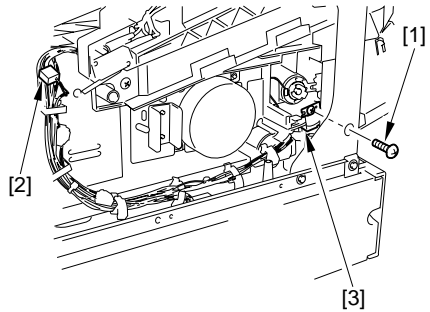

F06-502-08

5.3 Drive Assembly

5.3.1 Removing the Drive Assembly

- 1) Remove the fixing assembly (3.1 in Chapter7).
- 2) Remove the multifeeder roller (5.2.2 in Chapter6).
- 3) Remove the rear cover.
- 4) Remove the right rear over.
- 5) Remove the right upper cover.
- 6) Remove the left rear cover.
- 7) Remove the left upper cover.
- 8) Remove the copyboard cover.
- 9) Remove the cassette rear cover.
- 10) Disconnect the connector [1], and remove the 2 screws [2]; then, detach the delivery fan assembly [3].

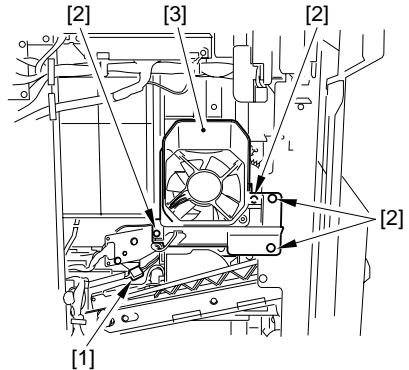

F06-503-01

- 11) Remove the 4 screws [4], and disconnect the 2 connectors [5]; then, detach the copyboard cover open/closed detecting unit [6].



When mounting the copyboard open/closed detecting unit, be sure to use the black binding screw 3 mm in diameter. Take care not to use the wrong screw.

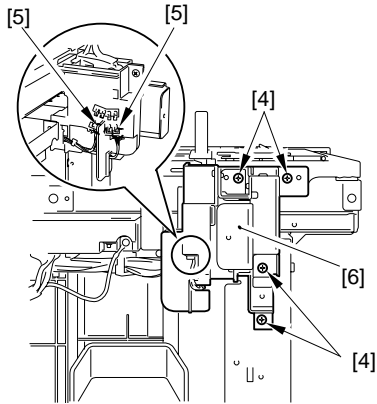

F06-503-02

- 12) Remove the 2 screws [7], and detach the fixing plate [8].

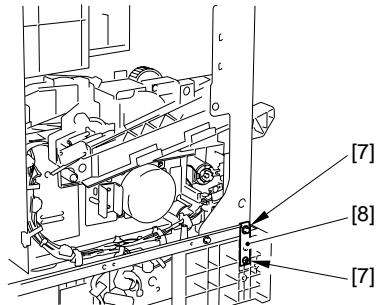

F06-503-03

- 13) Remove the 8 screws [9], and detach the support plate [10].

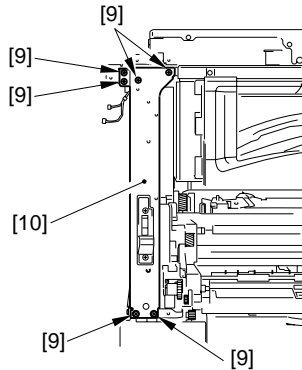
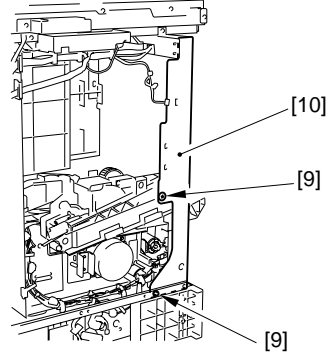

F06-503-04



In the absence of the support, take care not to impose a load on the reader unit. Take care not to use the wrong screw: the 4 screws to be used at the top are 3 mm in diameter, while the 4 screws to be used at the bottom is 4 mm in diameter.

- 14) Disconnect the connector [11], and remove the 3 screws [12]; then, detach the main motor [13].
- 15) Disconnect the connector [14], and free the harness [15] from the harness guide.
- 16) Remove the resin E-ring [16], and detach the registration clutch [17].
- 17) Remove the screw [18], disconnect the connector [19]; then, remove the multifeed pickup solenoid [20].

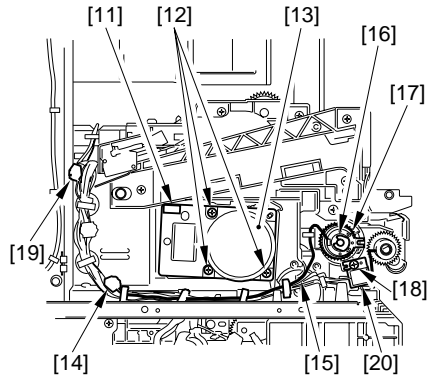

F06-503-05

- 18) Remove the 3 screws [21], and detach the left cover rail [22].

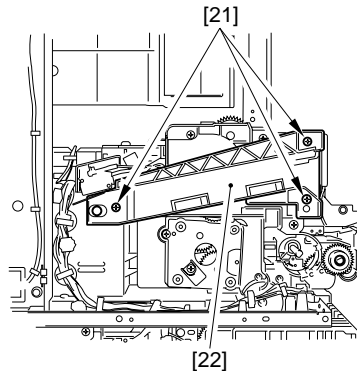

F06-503-06

- 19) Remove the shaft [25] and bushing [24] of the manual feed pickup roller gear [23].

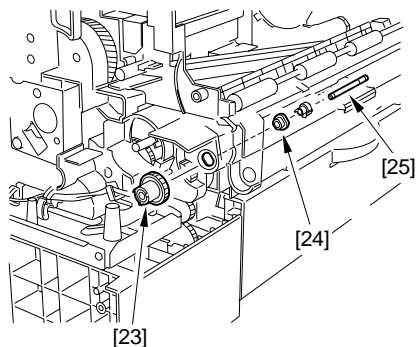

F06-503-07

- 20) Disconnect the connector [26] of the registration paper sensor.
- 21) Remove the 4 screws [27], and detach the drive assembly [28].

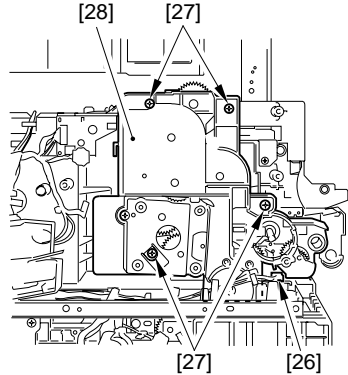

F06-503-08

5.4 Registration Roller Assembly

5.4.1 Removing the Registration Roller

- 1) Remove the drive assembly (5.3.1 in Chapter6).
- 2) Remove the 2 screws [1], and detach the leaf spring [2] from the boss [3].

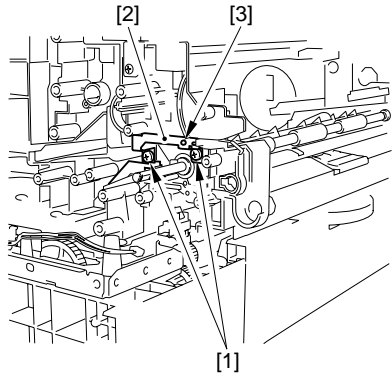

F06-504-01

- 3) Remove the screw [4], and detach the jam removing knob [5].

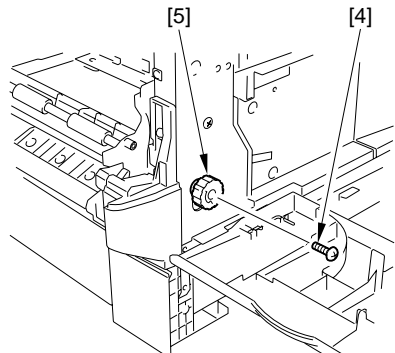

F06-504-02

- 4) Pull the registration roller [7] to the front, and detach the E-ring [7] and the bushing [8].
- 5) Remove the busing [9] at the rear, and detach the registration roller [6].

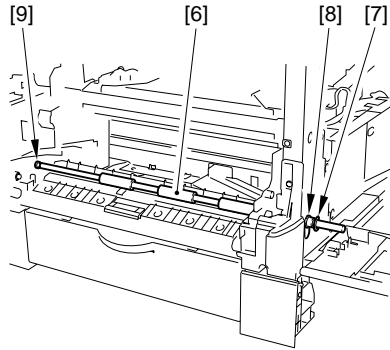

F06-504-03



When mounting the registration roller, check to make sure that the grounding plate [11] is in contact with the bushing [12] of the registration roller and the shaft [13] under the registration roller.

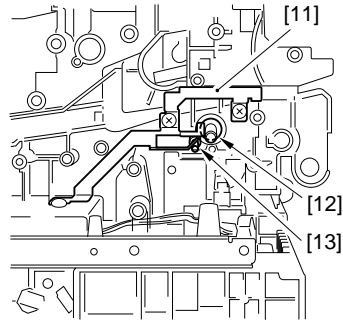

F06-504-04

5.4.2 Removing the Registration Paper Sensor

- 1) Remove the drive assembly (5.3.1 in Chapter 6).
- 2) Disconnect the connector [1].
- 3) Free the 4 claws [2], and detach the registration paper sensor [3].

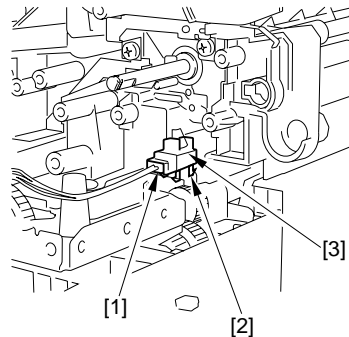

F06-504-05

5.4.3 Removing the Registration Clutch

- 1) Remove the rear cover and left rear cover.
- 2) Disconnect the connector [1], and free the harness [2] from the harness guide.
- 3) Remove the resin E-ring [3], and detach the registration clutch [4].

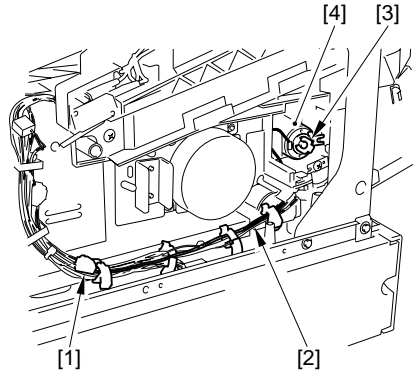

F06-504-06

CHAPTER 7

FIXING SYSTEM

1 Outline of Operation

1.1 Outline

The fixing roller of the fixing assembly and the delivery roller are driven by the main motor. After it is removed from the photosensitive drum, the paper is moved to the inside of the fixing assembly, where the toner image is fused to the fibers of the paper by the work of the fixing roller and pressure roller; thereafter, the paper is delivered outside the machine.

The fixing system has the following functions and uses the following methods:

Item	Description
Fixing method	Roller fixing
Fixing drive	From main motor (M101)
Control temperature	Varied according to selected mode
Temperature detection	[1] By main thermistor (temperature control, error detection) [2] Sub thermistor (error detection) [3] Thermal switch (error detection)
Fixing temperature control	[1] Control in response to power switch operation [2] Control according to paper type [3] Control at time of down sequence [4] Control in ESS (energy save) mode
Pressure roller cleaning	By cleaning mode in user mode
Error detection	[1] By thermistor (overheating) [2] Thermal switch (overheating)

T07-101-01

The fixing system is constructed of the following components:

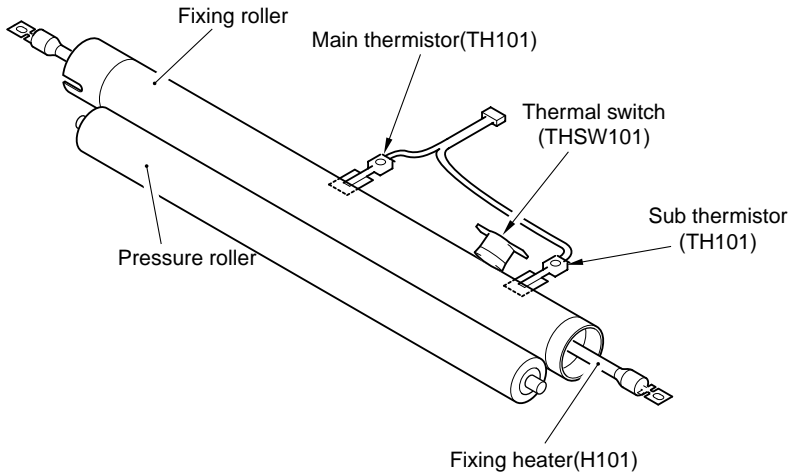

F07-101-01

Component	Description
Fixing roller	31 mm in dia.
Pressure roller	25 mm in dia.
Fixing heater (H101)	Halogen heater (800 W)
Main thermistor (TH101)	Temperature control, error detection
Sub thermistor (TH101)	Error detection
Thermal switch (THSW101)	Error detection ($230 \pm 10^{\circ}\text{C}$)

T07-101-02

2 Controlling the Fixing Temperature

2.1 Outline

The mechanism related to the control of fixing temperature consists of the following:

- [1] Controlling the fixing heater temperature
- [2] Detecting a thermistor error

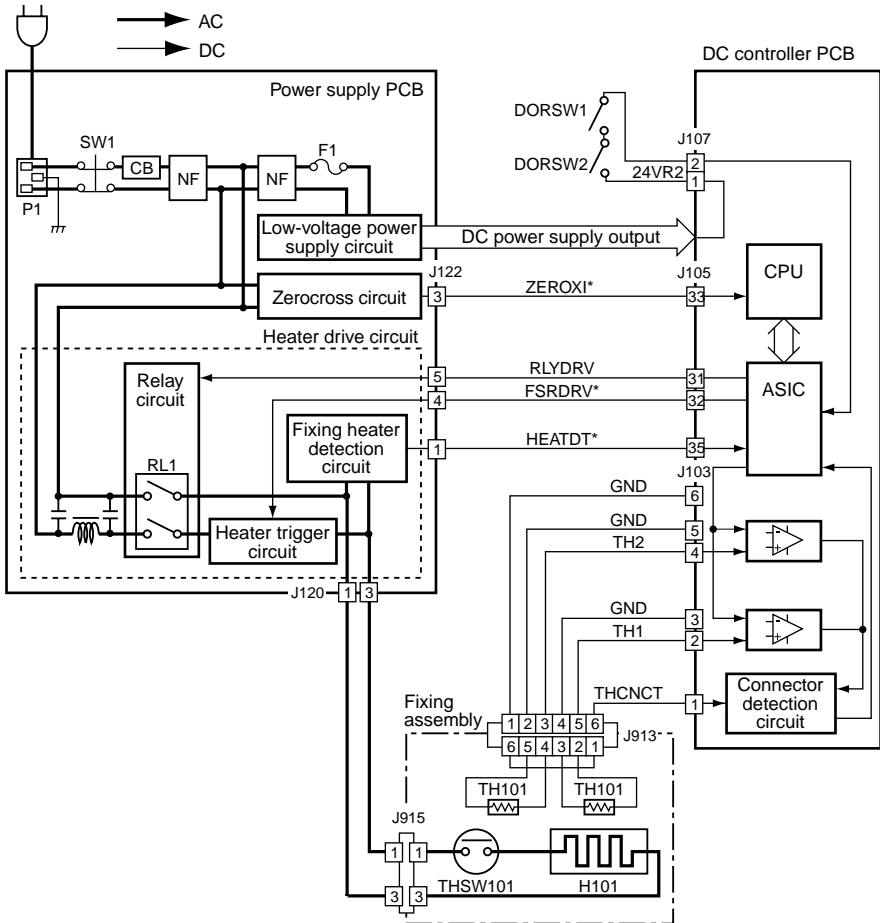

F07-201-01

2.2 Controlling the Temperature

The mechanism related to the control of fixing temperature consists of the following:

- [1] Control in response to the operation of the power switch
- [2] Control according to the type of paper
- [3] Control at time of down sequence
- [4] Control in ESS (energy save) mode

The sequence of control is as follows:

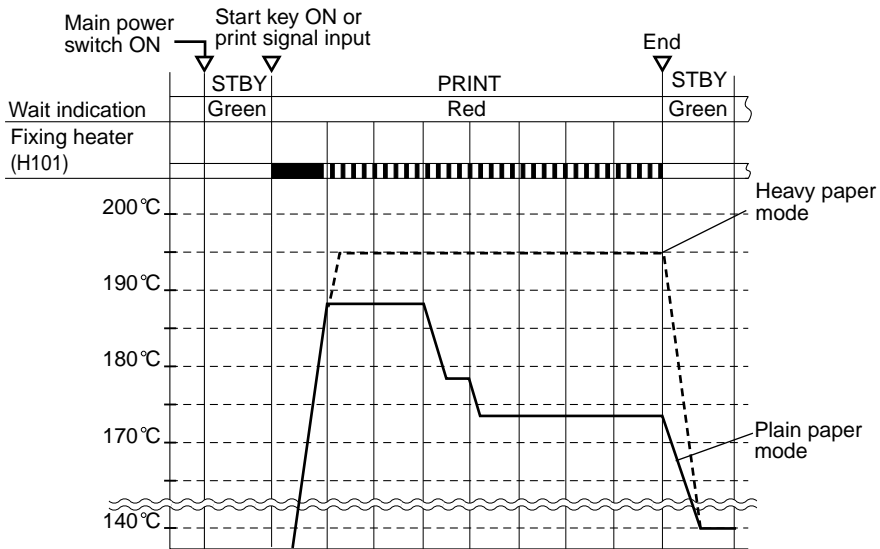

F07-202-01

2.2.1 Control at Time of Power-On

a. Conditions Ending the Wait Period

To decrease the length of the Wait period, the machine ends the period if any of the following conditions exits, thus shifting to standby state:

- 25 sec or more passes from the time when the fixing heater (H101) is first supplied with power and when the fixing temperature reaches 150°C or higher.
- 27 sec passes from the time when the fixing heater (H101) is first supplied with power and when the fixing temperature reaches 145°C or higher.
However, to ensure good fixing immediately after the power switch is turned on, the fixing heater is continuously kept ON until the target temperature is reached even when the machine remains in standby state.

b. Controlling to the Target Temperature

To ensure fixing immediately after the power switch is turned on, a target temperature is used as a reference, as determined in relation to the fixing temperature at time of when the power switch is turned on and to the state of the printer.

- If the fixing temperature is lower than 80°C when the power switch is turned on, For printing, a temperature higher than the control temperature is used (as determined by the selected mode). Printing is started when the target temperature is reached, and the target temperature is decreased in stages in relation to the passage of time (continuous printing) until the control temperature for a specific mode is reached.
- If the fixing temperature is 80°C or higher when the power switch is turned on, For printing, the control temperature is used as the target temperature (as determined by the selected mode). Printing is started when the target temperature is reached, and the target temperature is decreased in stages in relation to the passage of time (continuous printing) until the control temperature for a specific mode is reached.

2.2.2 Control According to the Type of Paper

The machine uses the following modes to suit the selected type of paper:

Mode	Control temperature during printing	Control temperature in standby	Remarks
Plain paper mode (default)	173°C	140°C	Used when printing on plain paper.
Heavy paper mode	195°C	140°C	Used when printing on paper with a coarse surface or in a low temperature environment. To ensure good fixing, the initial rotation period is extended by 5 sec; for continuous printing, the distance between sheets is increased.

T07-202-01

2.2.3 Control at Time of Down Sequence

In continuous printing, the temperature of the area not in contact with paper as detected by the sub thermistor can be abnormally high. To prevent overheating, the machine increases the distance between sheets.

- Down sequence is started when the reading of the sub thermistor is 210°C.
- Down sequence is ended when continuous printing ends.

2.2.4 Control in ESS (energy save mode)

In ESS mode, the machine may be in one of two states, depending on the selection of 'power at time of energy save mode' ('high' or 'low <default>'); hereafter, the former is referred to as ESS1 and the latter, ESS2.

Control for ESS1:

When the machine is in ESS1 state, the control temperature of the fixing heater is lowered to 120°C from 140°C (standby temperature).

The target temperature at the end of ESS1 is determined in relation to the fixing temperature and the printer state, as in the case of temperature control used at power-on.

Control for ESS2:

When the machine is in ESS2 state, the fixing heater (H101) remains OFF.

The target temperature at the end of ESS2 is determined in relation to the fixing temperature and the printer state, as in the case of temperature control at power-on.



The power save mode (energy save mode) for user mode at time of shipment from the factory is set to 15 min.

2.3 Detecting an Error

2.3.1 Outline

The machine checks for an error for the following in relation to fixing temperature control:

- [1] Temperature error detection by main thermistor
- [2] Temperature error detection by sub thermistor
- [3] Temperature error detection by thermal switch

2.3.2 Control in Response to an Error

- If the machine detects an error in the fixing assembly, the DC controller PCB operates as follows:
 - [1] It causes the FSRDRV* signal to go '1' to cut power to the fixing heater.
 - [2] It causes the RLYDRV signal to go '0' to turn off RL1, and indicates 'E000' through 'E004' on the LCD in the control panel.



When 'E000' through 'E004' is indicated, the NVRAM on the DC controller PCB remembers an error in the fixing assembly even when the power switch is turned off and then on. After turning on the power, be sure to execute the following in service mode to remove the error information: #7 PRINTER > #4 PRINTER RESET > YES = (*).

2.3.3 Conditions for Error Detection

The machine will detect an error in response to any of the following:

a. Start-Up Error

A start-up error is identified for the following (reading of the main thermistor):

- It exceeds 40°C, but does not reach 60°C in 10 sec.
- It exceeds 60°C, but does not reach 80°C in 10 sec.
- It exceeds 80°C, but does not reach 100°C in 10 sec.
- It exceeds 100°C, but does not reach 120°C in 10 sec.
- It exceeds 120°C, but does not reach 140°C in 10 sec.
- It exceeds 140°C, but does not reach 160°C in 10 sec.
- It exceeds 180°C, but does not reach 195°C in 10 sec.

b. Low Temperature Error

- The reading of the main thermistor does not reach 40°C within 14 sec after the fixing heater goes ON.

c. Low Temperature Error at Time of Temperature Control

- After the end of the Wait period, the reading of the main thermistor is 100°C or lower.
- At time of standby, the reading of the sub thermistor is 50°C or lower.

d. High Temperature Error

- The reading of the main thermistor is 220°C or higher.

e. Drive Circuit Error

- At time of initialization, the ZEROXI* signal of the power supply cannot be detected.
- The ZEROXI* signal does not arrive for 3 sec during temperature control.
- A triac short is detected (ASIC).

2.4 Protective Mechanism

The machine is equipped with the following protective mechanisms used to prevent malfunction of the fixing heater:

1. Thermistor High Temperature

The ASIC and the high temperature detection circuit on the DC controller monitor the voltage readings of the main thermistor and sub thermistor; if the main thermistor detects a voltage equivalent of the following temperature, the CPU will identify the condition as indicating overheating.

- 220°C or higher (read by main thermistor TH101)

2. Thermistor Disconnection

The connector detection circuit on the DC controller PCB monitors the THCNT signal, and the CPU will assume that the connector of the thermistor is disconnected if the signal is '0'.

3. Cutting Off the Power in Response to Overheating (as detected by the thermal switch)



If the internal temperature of the thermal switch (THSW101) exceeds about 230°C, the thermal switch will go OFF to cut the power to the fixing heater.

4. Detecting the Activation of the Fixing Heater

The fixing heater detection circuit on the power supply PCB causes the HEATDT* signal to go '0' if the FSRDRV* signal is '0' (fixing heater ON). As such, the ASIC will assume that the fixing heater activation is faulty (triac short circuit) if the HEATDT* signal goes '1'.

3 Disassembly and Assembly

Here, instructions on how to disassemble/assemble the machine are given together with explanations of its mechanical characteristics; be sure to keep the following in mind when going through the work:

1.  Before starting the work, be sure to disconnect the power plug. Moreover, if you have removed the drum unit, be sure to keep it in a protective bag.
2. Unless otherwise specially indicated, reverse the steps used to disassemble the machine when assembling it.
3. Identify the screws by type (length, diameter) and location.
4. To ensure electrical continuity, the mounting screws used for the grounding wire and arrestors are equipped with toothed washers. Do not leave them out when assembling the machine.
5.  As a rule, do not operate the machine with any of its parts removed.

3.1 Removing the Fixing Assembly

- 1) Remove the left cover.
- 2) Open the front cover.
- 3) Remove the drum unit (See to 7.1.1 in Chapter 5).
- 4) Remove the left front cover and the delivery upper cover.
- 5) Remove the right cover.
- 6) Remove the delivery cover.
- 7) Remove the fixing connector cover [1]. You will be using the cover once again; be sure to remove all glue.

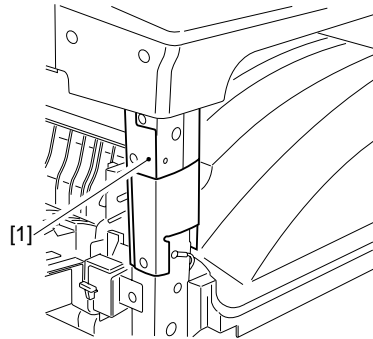

F07-301-01



When mounting the fixing connector cover, match the 2 screw holes [3] against the 2 holes [2] in the fixing connector cover removed previously. And attach the fixing connector cover [4].

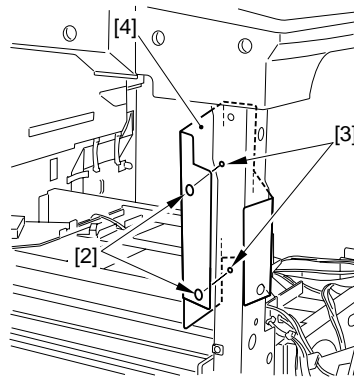

F07-301-02

- 8) Remove the 2 screws [5]; then, remove the grounding wire [6] and the fixing connector fixing plate [7].

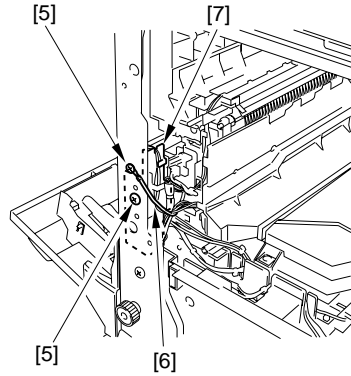

F07-301-03

- 9) Disconnect the 3 connectors [9] from the fixing connector fixing plate [8]; then, free the harness from the harness guide.

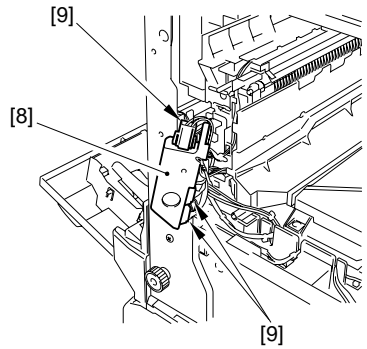

F07-301-04

10) Remove the 2 small stepped screws [10] and the 2 large stepped screws [11]. When removing the large stepped screws [12], be sure to insert a hex key (less than 2 mm in diameter) into the screw hole [13] and loosen them by turning the hex wrench.

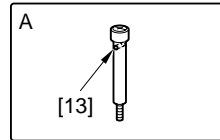
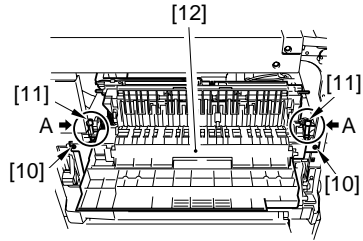

F07-301-05



1. After mounting the fixing assembly, check to make sure that the delivery lower cover [14] is behind the rear cover [15] as shown.
2. When mounting the fixing assembly, you may find it difficult to engage the fixing roller gear. If such is the case, release the locking lever [16], to which the fixing roller gear is linked.

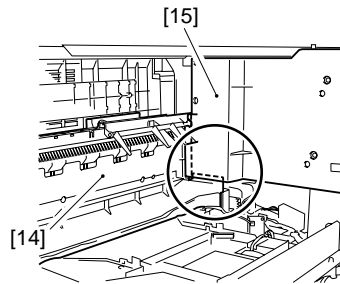

F07-301-06

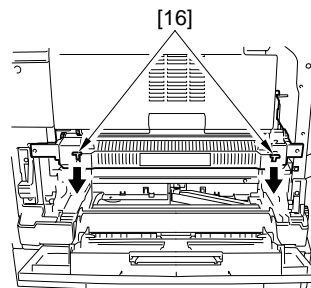

F07-301-07

3.2 Cleaning the Inside of the Fixing Assembly or Replacing Its Parts



Do not disassemble or clean the following parts found inside the fixing assembly in the field; a small inaccuracy in the torque or adjustment, or deformation by cleaning work, can cause smoking and flaming:

- Thermistor
- Thermal switch

3.3 Removing the Delivery Sensor

- 1) Remove the fixing assembly [1].
- 2) Disconnect the connector [2], and free the 4 claws [3]; then, detach the delivery sensor [4].

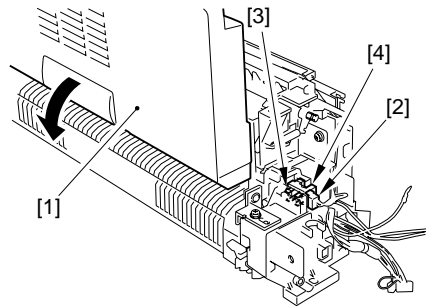

F07-303-01

3.4 Removing the Pressure Roller

- 1) Remove the fixing assembly. (See 3.1 of Chapter 7.)
- 2) Remove the screw [1], and detach the support plate [2].
- 3) Remove the fixing cover [3].

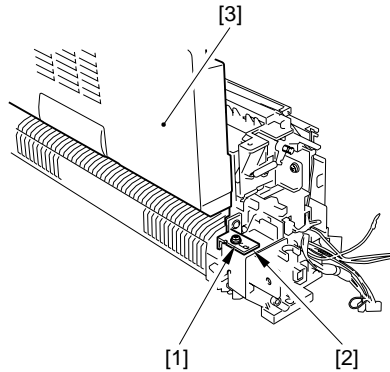

F07-304-01

- 4) Remove the screw [4], and detach the drive gear shaft plate [5] and the gear [6].
- 5) Free the claw [7], and detach the gear [8].
- 6) Remove the gear [9].

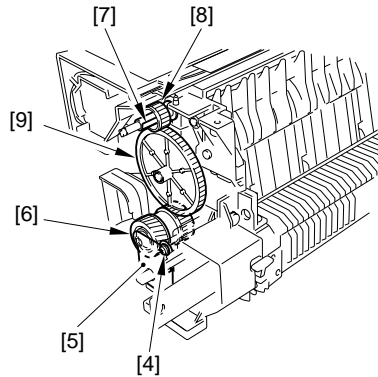

F07-304-02

- 7) Remove the 3 screws [10], and disconnect the connector [11]; then, detach the delivery roller unit [12].

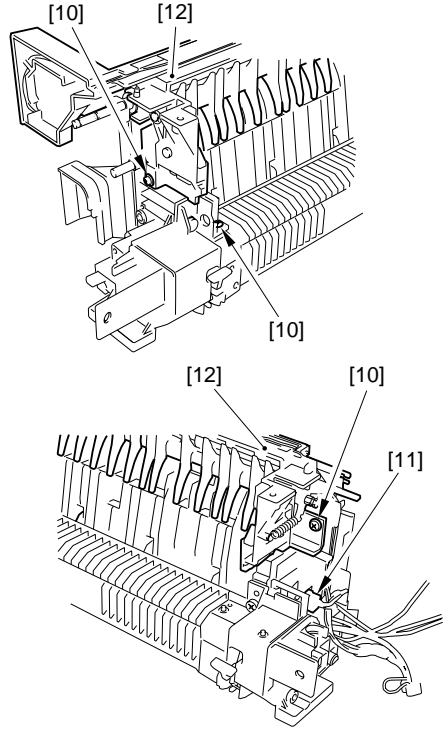

F07-304-03

- 8) Remove the 2 screws [13], and detach the delivery lower cover [14].

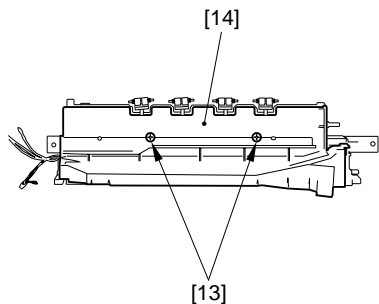

F07-304-04



The delivery roll [15] and the spring [16] tend to come off easily once the delivery lower cover has been removed. Take full care not to lose it.

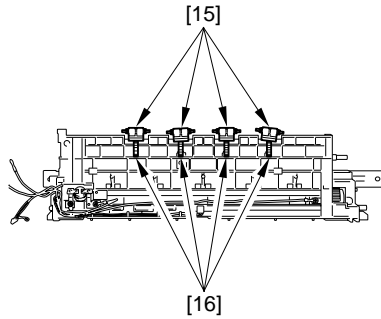

F07-304-05

- 9) Push down the pressure releasing lever [17] to remove the pressure.

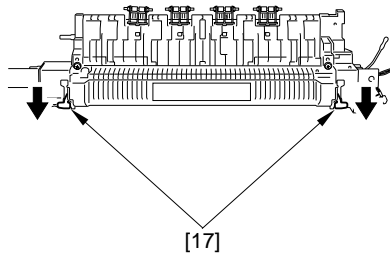

F07-304-06

- 10) Remove the 2 screws [18], and detach the 2 linking plates [19].

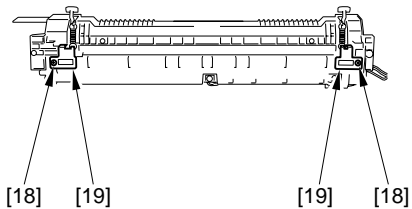

F07-304-07

- 11) Remove the 2 screws [20], and open the pressure roller assembly [21]; then, remove the D-cut shaft found on the right side.

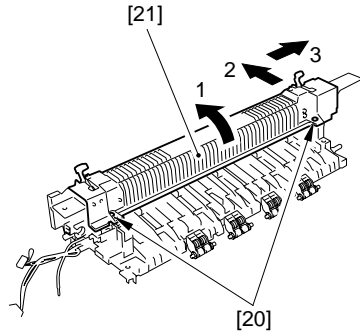

F07-304-08



1. The static eliminating brush [22] can come off. Take care not to lose it.
2. Do not tilt the fixing roller assembly [23]; otherwise, the fixing roller can come off the bushing. Be sure to place it on a flat surface.

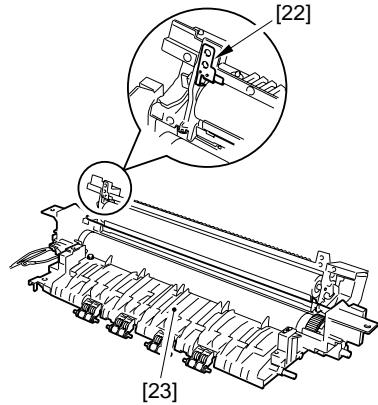

F07-304-09

- 12) Remove the 2 screws [24] for the pressure roller assembly, and detach the inlet guide [25].

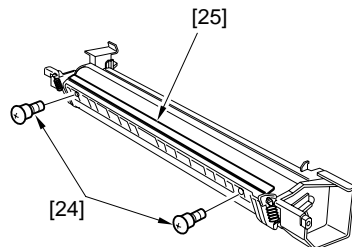

F07-304-10

- 13) Push down the pressure releasing lever to lock it in place.
- 14) Remove the left/right spring [26]; then, push down the 2 bushings [27] in the direction of the arrow to detach.
- 15) Remove the bearings [28] (2 each on left and right), and detach the pressure roller [29].

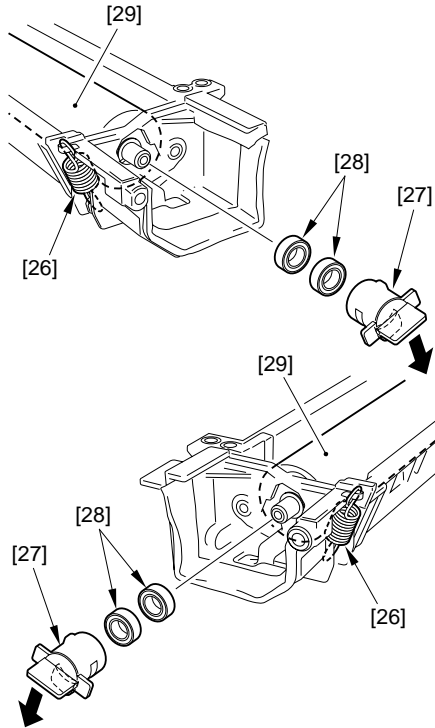

F07-304-11



If the pressure releasing lever [30] or the fixing shaft [31] has come off when the pressure roller is removed, be sure to mount them back as shown.

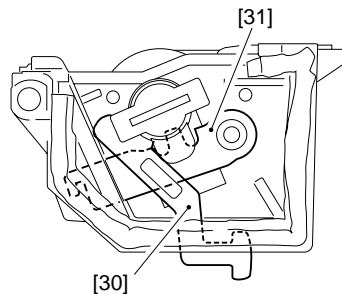

F07-304-12



When mounting the pressure roller, check to make sure that the contact plate [32] is in contact with the inlet guide [33].

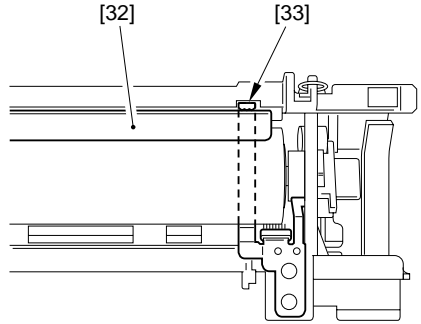

F07-304-13

3.5 Removing the Fixing Roller/Fixing Heater/Separation Claw

- 1) Remove the fixing assembly. (See 3.1 of Chapter 7.)
- 2) Remove the pressure roller assembly. (See 3.4 of Chapter 7.)
- 3) Remove the 2 screws [1] of the fixing roller assembly; then, detach the fixing roller [2] and the fixing heater [3].

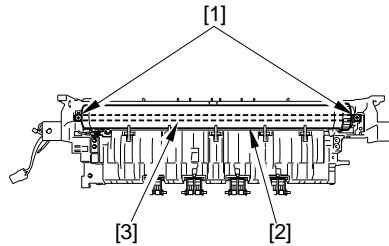

F07-305-01

- 4) Check the thermistor [4] and the thermal switch [5] for scratches, dirt, and deformation. If any, replace the fixing assembly.

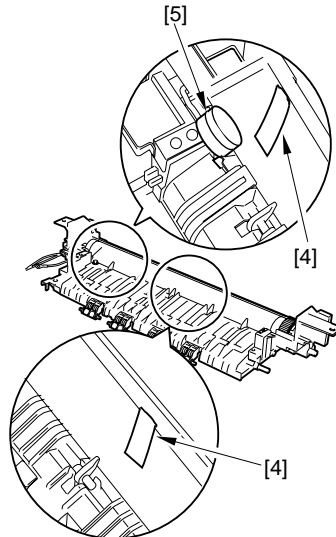

F07-305-02



Do not clean the thermistor [4] or the thermal switch [5].

- 5) Remove the spring [6], detach the separation claw [7].

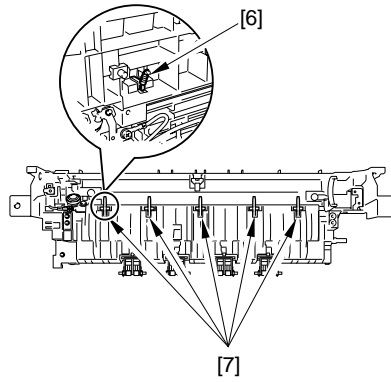

F07-305-03

3.6 Mounting the Fixing Roller/Fixing Heater/Separation Claw

- 1) Mount the 5 separation claws with the 5 springs.



Check to make sure that the contact plate [2] and bushing [3] is mounted.

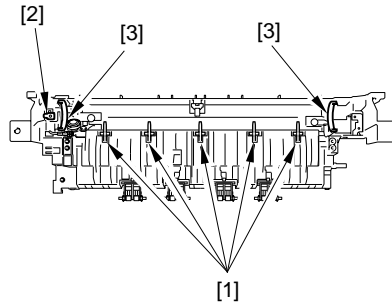

F07-306-01

- 2) Open the separation claws [1] to insert the fixing roller [4]. Obtain a sheet of A3/11x17 white paper, fold it in 4, and fit it as shown.
- 3) With the fixing heater [5] fitted in the fixing roller [4], hold the fixing roller [4] in your hand.
- 4) With attention to the separation claws [3], force the fixing roller [4] against the paper and place it on the fixing assembly.

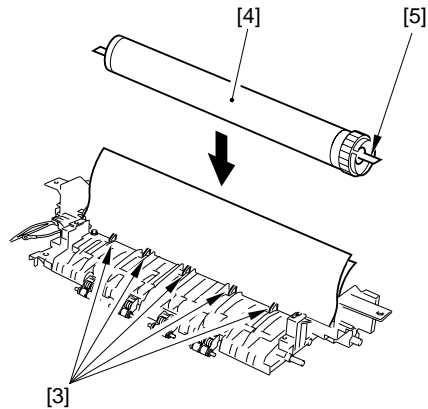

F07-306-02

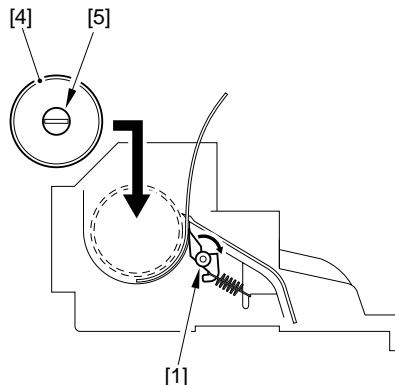

F07-306-03

- 5) Remove the paper.
- 6) Mount the fixing heater[7] with two screws[6].



1. Be sure to mount the fixing heater so that its edge with print faces upward. Further, take care not to touch the glass portion of the fixing heater.
2. When mounting the fixing roller, take care not to scratch it by any of the separation claws.

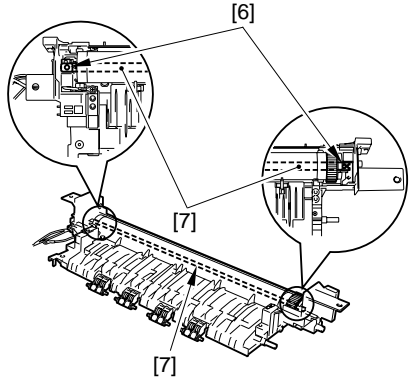

F07-306-04

- 7) Prepare a length of paper [8] (plain paper) cut to a width of about 20 mm.
- 8) Put the length of paper [8] between the thermistor [9] and the fixing roller [10] then, check to make user that the thermistor [9] is in firm contact with the fixing roller [10].

Front View

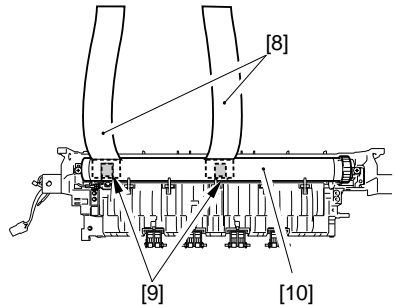

F07-306-05

Cross Section

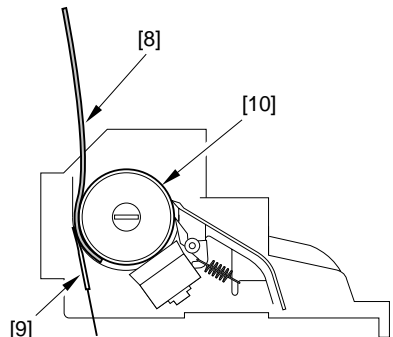

F07-306-06

- 9) After mounting the fixing roller and the fixing heater, push the fixing aluminum core [11] with your finger lightly so as to make sure that the thermal switch [12] returns to its initial position by the spring.

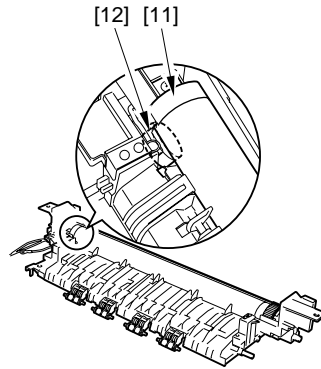

F07-306-07

- 10) Check to make sure that the static removing brush [13] is in contact with the fixing roller core [14].

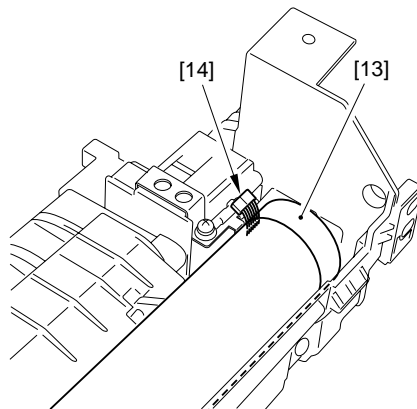

F07-306-08

- 11) After making the check, mount the fixing assembly to the machine using the steps used to remove it but in reverse.

CHAPTER 8

EXTERNALS AND AUXILIARY CONTROL SYSTEM

1 Control Panel

1.1 The machine's control panel has the following construction

The circuitry of the control panel consists of two PCBs, and is controlled by the ASIC of the image processor PCB.

The indication on the LCD is in 2 lines of 20 characters each.

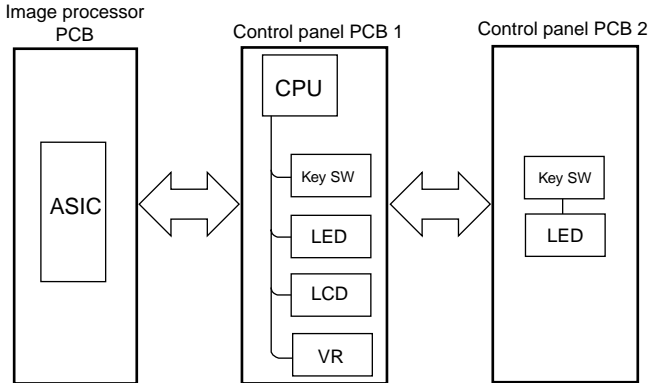

F08-101-01

2 Power supply

2.1 Power Supply

2.1.1 Outline

The machine's DC power is generated by the AC power received by the power supply PCB. The generated DC power is converted into a full-time ON system (linked to the power switch) and a remote ON/OFF system (linked to control signals), and is supplied to each load.

The output of the power supply PCB is controlled by the power switch (SW101) or signals from the printer board.

The names and functions of the parts associated with the power supply are as follows:

Name	Description
Power supply PCB	generates DC power from AC power
Power switch (SW101)	supplies AC power to the power supply PCB
Cover switch (DORSW1, DORSW2)	detects state (open/closed) of front cover and left cover cuts 24VR2 power to main motor

T08-201-01

The levels of outputs from the DC power supply of the full-time ON system are as follows:

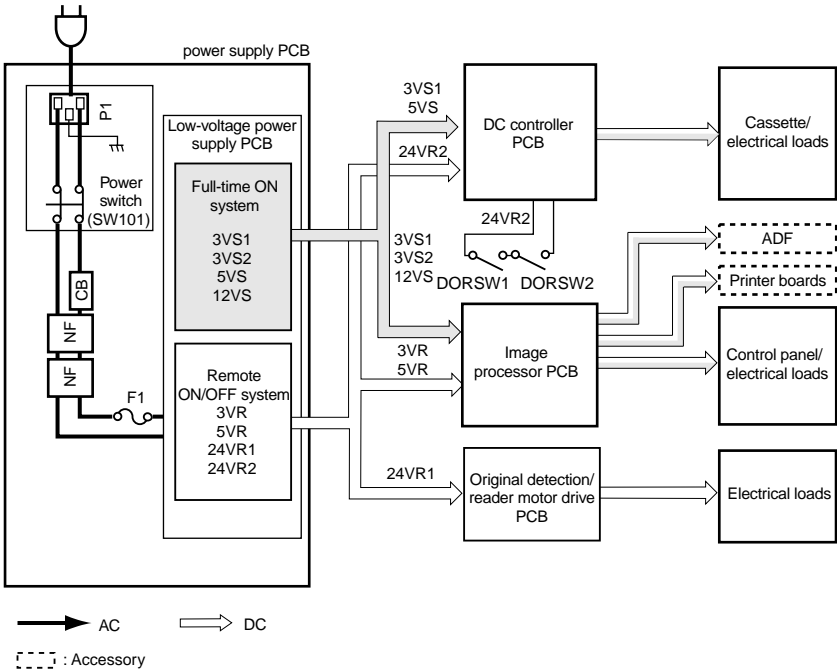

F08-201-01

2.1.2 Rated Outputs from the Power Supply PCB

The levels of outputs from the DC power supply of the full-time ON system are as follows:

Output	3VS1	3VS2	5VS	12VS
Connector	CN1-11 CN1-13 CN2-8 CN2-9	CN1-15 CN1-17 CN1-19 CN1-20	CN2-12 CN2-13	CN1-1
Output voltage tolerance	±3%	±3%	±5%	±5%
Rated output voltage	3.45V	3.45V	5.05V	12V
Rated output current	4.3A	4.3A	1.9A	0.6A
Activation level of overcurrent protection mechanism	8.0A	8.0A	4.0A	3.0A

T08-201-02

The levels of outputs from the DC power supply of the remote ON/OFF system are as follows:

Output	3VR	5VR	24VR1	24VR2
Connector	CN1-7	CN1-6	CN3-1 CN3-2	CN2-18 CN2-27
Output voltage tolerance	±5%	±5%	±5%	±5%
Rated output voltage	3.35V	5.05V	24V	24V
Rated output current	0.3A	1.0A	5.0A	5.0A
Activation level of overcurrent protection mechanism	4.0A	3.0A	8.0A	8.0A

T08-201-03

* The above levels apply when the AC input is between 85 and 135 V for the 120V model and between 187 and 264 V for the 230V model.

2.2 Protective Mechanisms

The power supply PCB is equipped with overcurrent/over-voltage protective mechanisms that will automatically cut off the output voltage to prevent faults in the power supply circuitry otherwise caused by a fault in any of the loads (e.g., short-circuit).

When the overcurrent/over-voltage protective mechanism has gone ON, correct the fault in the load, and turn on the power switch once again to reset the machine.

The circuitry is equipped with a fuse, which will blow to cut off the power in response to an overcurrent in the AC line.

2.3 High-Voltage Power Supply Circuit

The high-voltage output circuit is built into the DC controller PCB. The ASIC on the DC controller PCB sends the following commands for the generation of high voltage at such times as needed:

- primary charging roller application voltage (AC voltage + DC negative voltage)
- developing bias (AC voltage + DC negative voltage)
- transfer charging roller application voltage (DC positive voltage or DC negative voltage)

For the control of biases applied to each load, see “Image Formation System” in Chapter 5.

3 Control at Time of Energy Save Mode

3.1 Outline

The machine is equipped with energy save mode (hereafter, ESS) used to save on power the machine consumes in standby state.

The machine turns on the ESS mechanism for the following:

- [1] When the machine has remained in standby for a specific period of time*.
 - As determined in user mode. (standby time: 3 to 30 min; 15 min factory default)
- [2] When the Energy Save key in the control panel is pressed.

3.2 Control

The ESS mechanism is controlled by the image processor PCB, and is controlled as follows (for ESS1/ESS2 control, see 2.2.4 in Chapter 7):

- [1] When the machine has remained in standby state for a specific period of time,
If the machine has remained in standby state for a specific period of time at the end of which the ESS mechanism is set to go ON (as set in user mode), the ASIC on the image processor PCB generates the ESS control signal, which is used to cut off the supply voltage sent to the remote ON/OFF system.
In ESS1 control, however, 24VR2 to the DC controller PCB is retained for control of the fixing heater.
- [2] When the Energy Save key in the control panel is pressed,
If the Energy Save key on the control panel is pressed, the ESS input signal will be sent to the ASIC on the image processor PCB.
Based on the control signal, the ASIC sends the ESS control signal, which in return will be used to cut off the supply voltage to the remote ON/OFF control system.
In ESS1 control, however, 24VR2 to the DC controller PCB is retained for control of the fixing heater.



Power Consumption in Standby

Normal standby : about 30 W

ESS1 control : about 20 W

ESS2 control : about 4.8 W

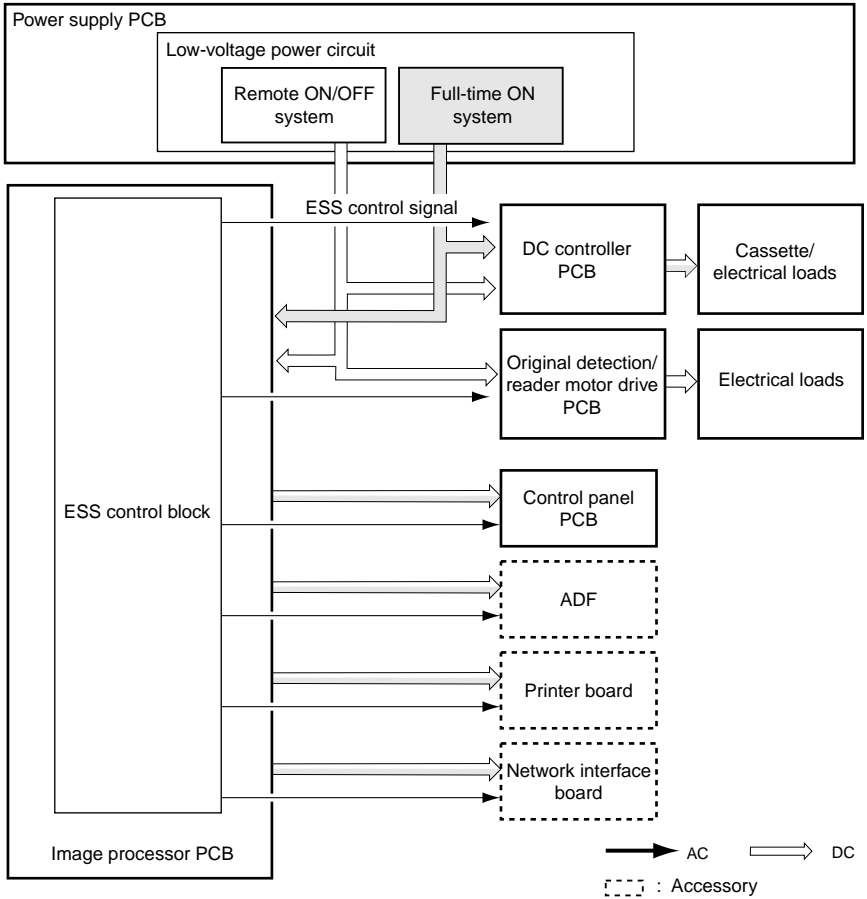

F08-301-01

3.3 Operation

While the machine is in ESS mode, all but the LED indicator of the Energy Save key in the control panel remain OFF. The machine will not start ESS mode for the following:

- [1] absence of paper, jam, absence of toner, service error (i.e., the Error lamp is ON)
- [2] presence of original in ADF (accessory)
- [3] shift to ESS enabled for printer board, network board (if mounted)

The machine ends ESS mode in response to another press on the Energy Save key in the control panel; it will also end the mode for the following:

- [1] presence of original in ADF (accessory)
- [2] copyboard cover open
- [3] print command from printer board (if mounted)
- [4] print command or start-up command from network interface board (if mounted)

4 Fan

4.1 Outline

The machine is equipped with a single fan for discharge of heat from inside it.

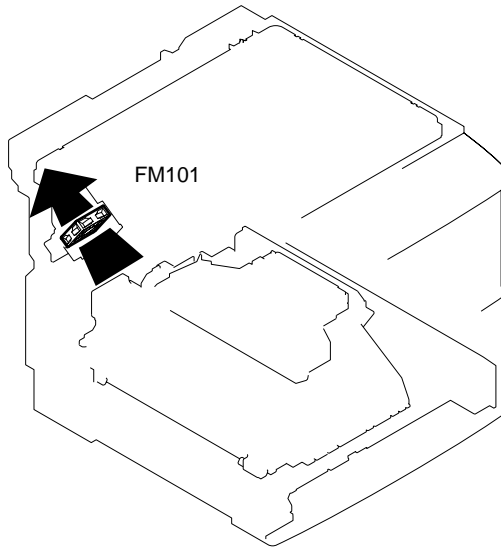

F08-401-01

4.2 Control

4.2.1 Controlling the Speed

The machine's heat discharge fan (FM101) is subjected to 2-speed control (full-speed and half-speed) as follows:

[1] Full-Speed Control

When the ASIC on the DC controller PCB causes the fan ON signal (FANON) to go '1' and the fan full-speed rotation signal (FANFULL) to go '1', the drive voltage control block supplies fan drive voltage (FANDRV) of +24 V to rotate the heat discharge fan to rotate at full speed.

[2] Half-Speed Control

When the ASIC on the DC control PCB causes the fan ON signal (FANON) to go '1' and the fan full-speed rotation signal (FANFULL) to go '0', +16V fan drive voltage (FANDRV) is supplied to rotate the heat-discharge fan at half speed.

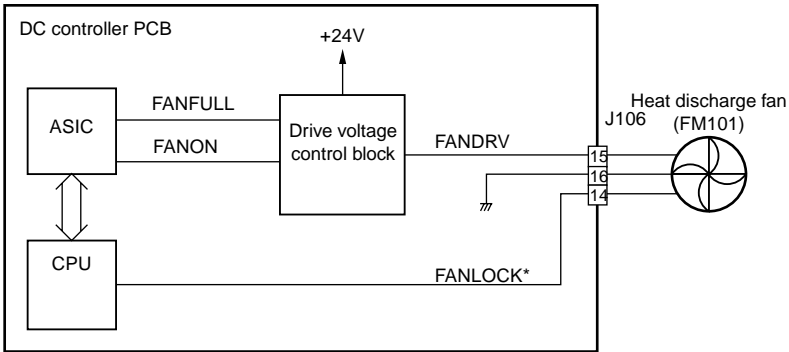

F08-402-01

4.2.2 Error Detection

As long as the heat discharge fan is rotating, the CPU on the DC controller PCB monitors the full-time fan lock detection signal (FANLOCK*); if the signal remains '0' for a specific period of time, it uses error code E805.

4.2.3 Sequence of Operation (fan drive)

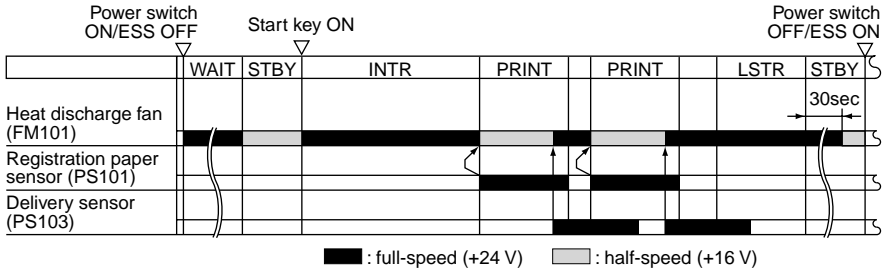

F08-402-02

5 Back-Up Battery

5.1 Back-Up Mechanism

5.1.1 Outline

The machine's image processor is equipped with a lithium battery (BAT1) for data back-up, needed in the event of a power shortage or when the power switch is turned off.



Do not throw the lithium battery into fire. It contains lithium and organic solvent (highly combustible), and it can explode or burn with strong intensity in fire.

Also, do not disassemble it, as its organic solvent can harm your skin upon contact.

Take full care when handling the battery, and be sure to dispose of it according to appropriate regulations.

5.1.2 Lithium Battery (BAT1)

The data backed up by BAT1 is control data on of user data or printer functions and service mode settings.

Battery life : 5 yr (approx.)

When the battery reaches the end of its life, the display will indicate 'DATA ERROR' when the power is turned on.

The battery cannot be replaced on its own. Upon exhaustion, the image processor PCB itself must be replaced.



If you disconnect the jumper plug (JP201) from the image processor PCB, and turn off the machine, all control data will be reset to default settings. If you must disconnect JP201, therefore, be sure to print out the control data, and enter the data after connecting JP201.



Points to Note When Replacing the Image Processor PCB

1. Before replacing the image processor PCB, print out all data.
2. The image processor PCB available as a service part is not equipped with a jumper plug (JP201) so as to avoid the exhaustion of the lithium battery.
 - You must remove JP201 from the existing image processor, and attach it to the new image processor.
3. If a few minute has passed before the machine is turned on, the display will indicate 'DATA ERROR'. If you press the OK key in the control panel, the data in control memory will be reset to factory settings, and the machine will enter standby state. If the display indicate "SYSTEM ERROR E000" you will need to restart the machine.
4. Be sure to enter the data for control memory you printed before replacing the image processor PCB.

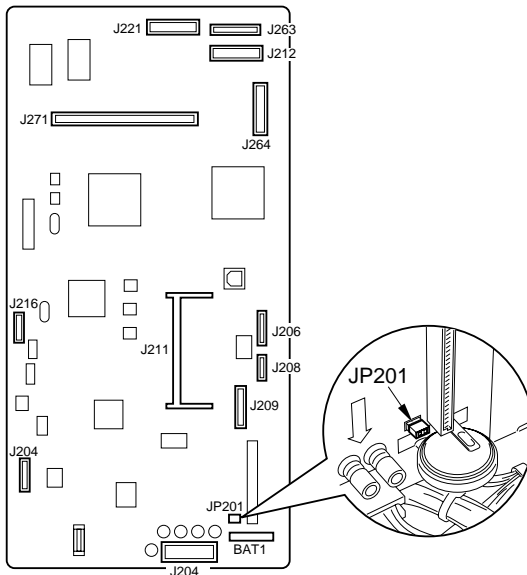

F08-501-01

5.2 Back-Up Data

5.2.1 Types of Data

The lithium battery (BAT1) on the image processor PCB serves to back up the following types of data; the types of data under a and b are stored in control memory (backed up by lithium battery BAT1):

a. User Data

It is the type of data called into use by the Function keys in the control panel.

Item	Description
USER DATA LIST	1. various copy mode settings 2. various printer mode settings

T08-502-01

b. Service Mode Data

Item	Description	Remarks
#1. SSSW	count size settings	
#2. MENU	not used	
#3. NUMERIC Param.	not used	
#4A. SPECIAL	not used	
#4B. NCU	not used	
#4C. ISDN	not used	
#5. TYPE	not used normally	
#6. SCANNER	not used normally	Note
#7. PRINTER	reduction/cassette selection settings	
#8. PDL	not used normally	
#9. COUNTER	maintenance/parts replacement guides	
#10. REPORT	report output for various service data	
#11. DOWNLOAD	downloading to ROM on various PCBs	
#12. CLEAR	initializing various data to default settings	
#13. ROM	version indication	

Note: used when replacing PCB

T08-502-02

5.2.2 Printing Out the Back-Up Data List

A list of data backed up in control memory may be printed out. Be sure to obtain a list of data before removing the jumper plug (JP201) from the image processor before replacing the image processor PCB. (You must turn off the power switch before doing so.)

a. User Data

Item	List
Settings mode data	User data list
	T08-502-03

b. Service Mode Data

Item	List
Service mode data	System data list or counter report
	T08-502-04





Memo

System Data List
 service mode #1 through #7, #13, start date output
 Counter Report:
 maintenance/part counter output
 user data list, changes from defaults on system data list, system dump list
 (not used) output.

6 Disassembly and Assembly

Here, instructions on how to disassemble/assemble the machine are given together with explanations of its mechanical characteristics; be sure to keep the following in mind when going through the work:

1.  Before starting the work, be sure to disconnect the power plug. Moreover, if you have removed the drum unit, be sure to keep it in a protective bag.
2. Unless otherwise specially indicated, reverse the steps used to disassemble the machine when assembling it.
3. Identify the screws by type (length, diameter) and location.
4. To ensure electrical continuity, the mounting screws used for the grounding wire and arrestors are equipped with toothed washers. Do not leave them out when assembling the machine.
5.  As a rule, do not operate the machine with any of its parts removed.

6.1 External Covers

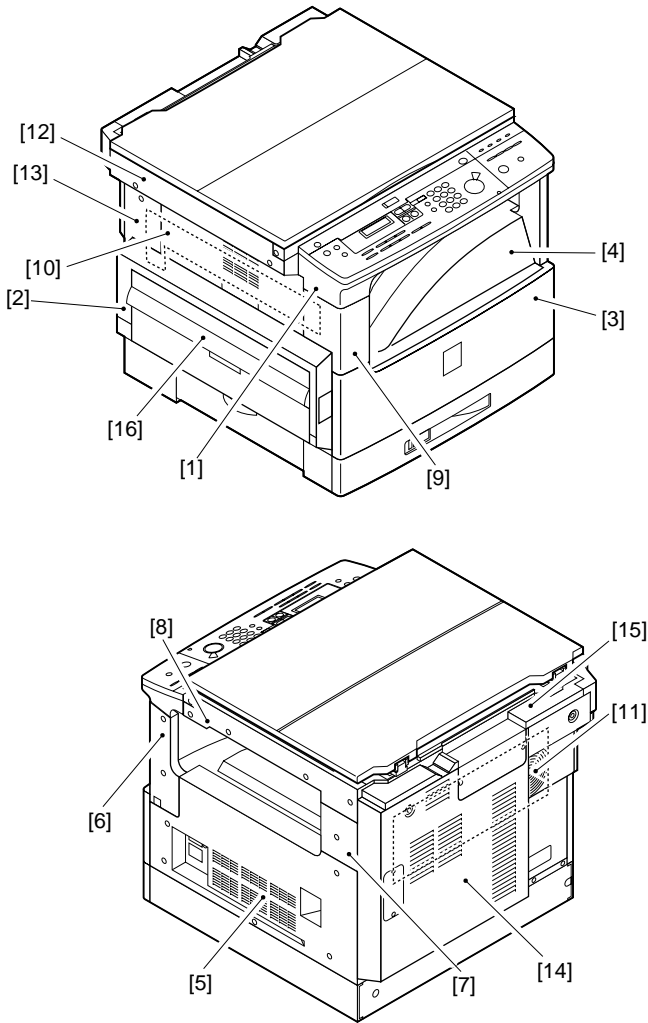

F08-601-01

- [1] Control panel lower cover (3 screws)
- [2] Left cover
- [3] Front cover (1 L-shaped pin and 1 screw)
- [4] Delivery tray (2 screws)*
- [5] Right cover (5 screws)
- [6] Right support cover (2 screws)*
- [7] Right rear cover (1 screw)
- [8] Right upper cover (5 screws)
- [9] Left front cover (2 screws)
- [10] Delivery upper cover
- [11] Delivery rear cover (4 screws)*
- [12] Left upper cover (4 screws)
- [13] Left rear over (3 screws)
- [14] Rear cover (7 screws; however, 13 screws if PCL printer board is mounted)
- [15] Rear upper cover (3 screws)*
- [16] Multifeder tray

*Must be removed in specific sequence.

Remove the external covers in the following sequence:

Target cover	Cover to remove
[4] Delivery tray ←	[5] Right cover ← [10] Delivery upper cover ← [9] Left front cover
[6] Right support cover ←	[5] Right cover
[11] Delivery right cover ←	[4] Delivery tray ← [2] Right cover ← [10] Delivery upper cover ← [9] Left front cover
[13] Left rear cover ←	[16] Multifeder tray
[15] Rear upper cover ←	[14] Rear cover ← [12] Left upper cover ← [8] Right upper cover ← ADF or copyboard cover

6.1.1 Removing the Front Cover

- 1) Open the front cover [1], and remove the screw [2]; then, remove the door tape [3].
- 2) Remove the 2 L-shaped pins [4], and detach the front cover [1].

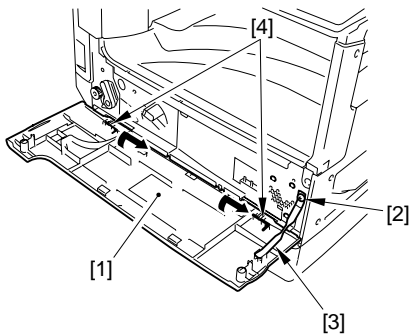

F08-601-02

6.1.2 Removing the Control Panel Lower Cover

- 1) Remove the 3 screws [1].

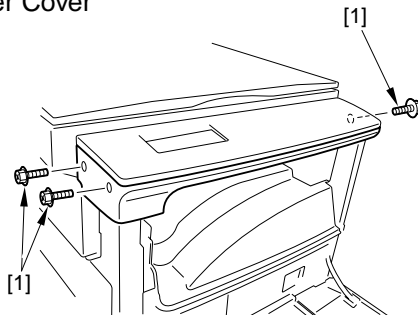

F08-601-03

- 2) Free the 4 claws [2], and detach the control panel lower cover [3].

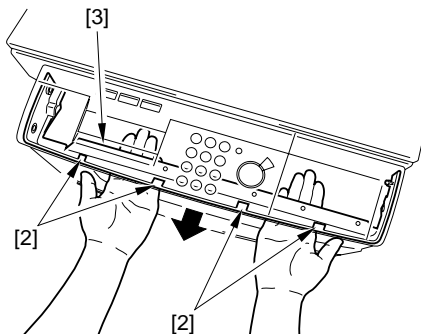

F08-601-04

6.2 Control Panel

6.2.1 Removing the Control Panel

- 1) Remove the control panel lower cover.
(See to 6.1.2)
- 2) Remove the 2 screws [1], and detach the control panel upper cover [2].

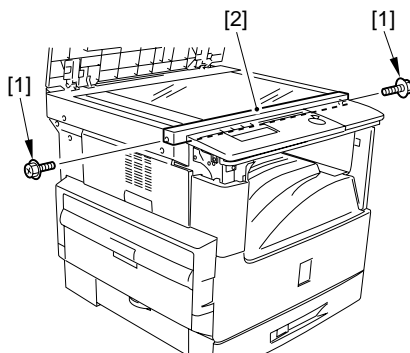

F08-602-01

- 3) Remove the 2 screws [3] each from the left and right, and 1 screw [4] each from the grounding wire on the left and right.

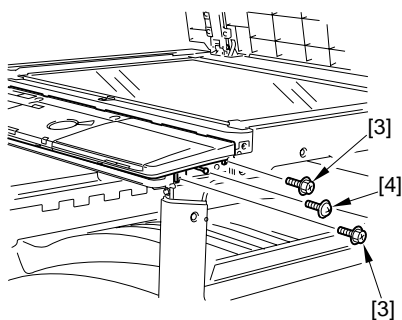
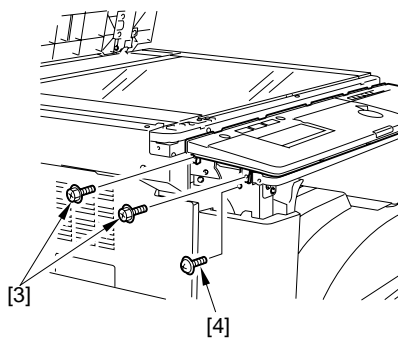

F08-602-02

- 4) Disconnect the 2 connectors [5] from behind the control panel, and detach the control panel [6].

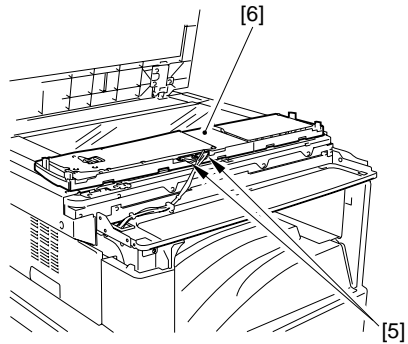

F08-602-03

6.3 Main Motor

6.3.1 Removing the Main Motor

- 1) Remove the rear cover.
- 2) Remove the printer board unit. (if equipped with printer functions; see 6.5.11)
- 3) Disconnect the connector [1].
- 4) Remove the 3 screws [2], and detach the main motor [3].

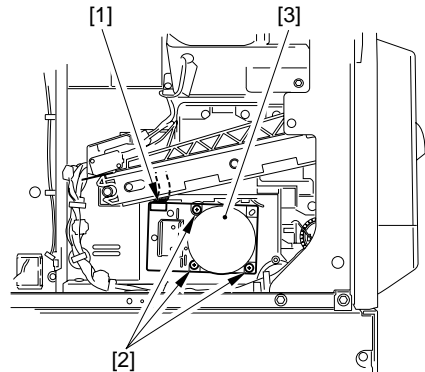

F08-603-01

6.4 Fan

6.4.1 Removing the Heat Discharge Fan

- 1) Remove the rear cover.
- 2) Remove the printer board unit. (if equipped with printer functions; see 6.5.11)
- 3) Disconnect the connector [1].
- 4) Remove the 4 screws [2], and detach the heat discharge fan assembly [3].

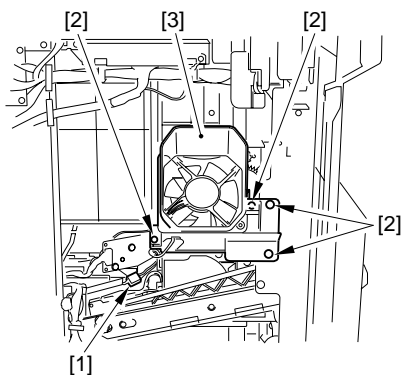

F08-604-01

- 5) Remove the 2 screws [4], and detach the heat discharge fan [5].

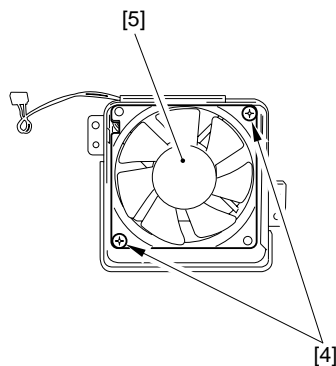

F08-604-02



When mounting the heat discharge fan, be sure to match the arrow [6] indicating the direction of air current and the arrow [7] on the hood.

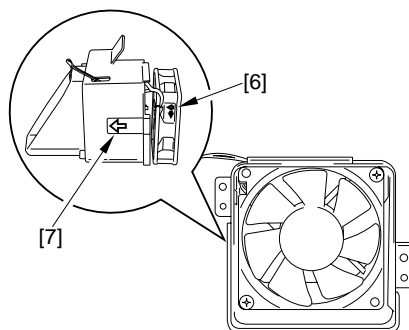

F08-604-03

6.5 PCBs

6.5.1 Removing the DC Controller PCB

- 1) Remove the power supply PCB. (6.5.9 in Chapter 8)
- 2) Disconnect all connectors [1] and the flexible cable [2] from the DC controller PCB.
- 3) Remove the 3 screws [3], and detach the DC controller PCB [4].

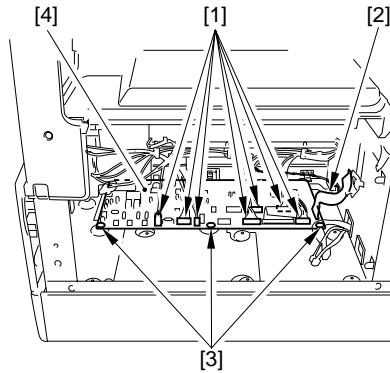

F08-605-01



When mounting the PCB, be sure that the 3 high-voltage contacts [5] are as indicated.

- 4) If you have replaced the PCB, go through the instructions given for replacement (See to 2.3.5 in Chapter 13).

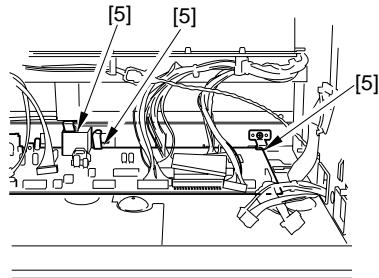

F08-605-02

6.5.2 After Replacing the DC Controller PCB

- 1) After replacing the PCB, go through the steps given under 2.1.3 of Chapter 13 to adjust the leading edge margin and to check if the image leading edge margin is as indicated.
- 2) If not, perform the steps so that the margin is as indicated.

6.5.3 Removing the Image Processor PCB

- 1) If you have replaced the PCB, go through the instructions given for replacement (See to 2.3.4 in Chapter13).
- 2) Remove the rear cover.
- 3) Disconnect all connectors and the flexible cable [1] from the image processor PCB.
- 4) Remove the 6 screws [2], and detach the image processor PCB [3].
- 5) If you have replaced the PCB, go through the instructions given for replacement (See to 2.3.4 in Chapter13).

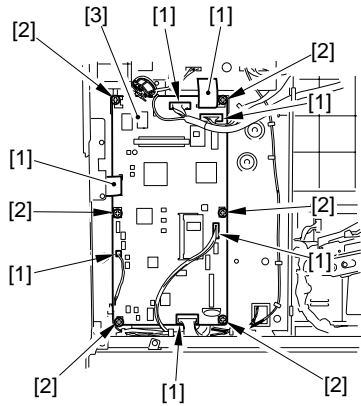

F08-605-03

6.5.4 When Replacing the Image Processor PCB

Go through the steps given for the replacement of the image processor in 2.3.4 of Chapter 13.

6.5.5 Removing the RAM DIMM

- 1) Taking care not to touch the elements, push down the socket lever [1], and detach the RAM DIMM [2].

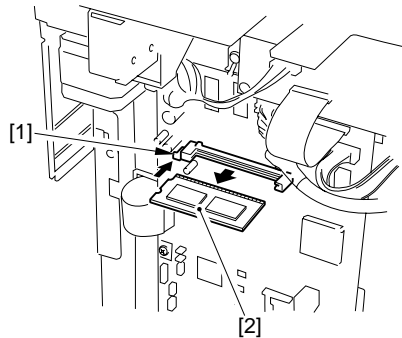

F08-605-04

6.5.6 Removing the ROM DIMM

- 1) Holding the right edge of the ROM DIMM [1], pull it to the front and slide it to remove.

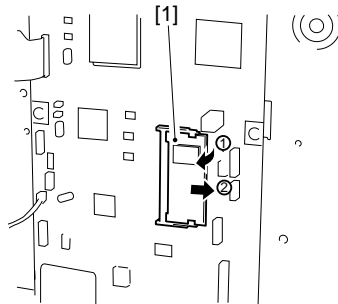

F08-605-05

6.5.7 Removing the Analog Processor PCB

- 1) Remove the rear upper cover.
- 2) Remove the 2 screws [1], and detach the copyboard glass retainer (right) [2].
- 3) Remove the copyboard glass [3].

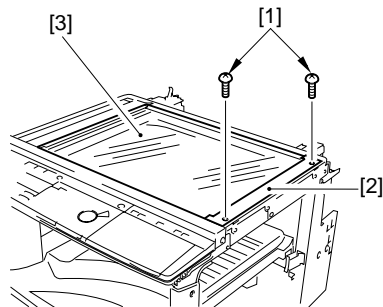

F08-605-06

- 4) Remove other screw [4], and detach the flexible cable retainer [5].
- 5) Remove the flexible cable [6].
- 6) Remove the 3 screws [7], and detach the protective panel [8].

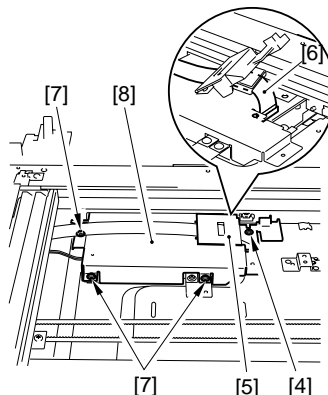

F08-605-07

- 7) Disconnect the connector [9], and remove the 3 screws [10].

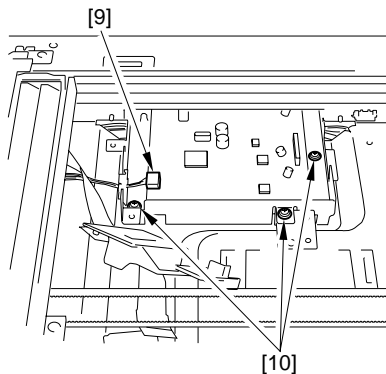

F08-605-08

- 8) Remove the printer board. (if equipped with printer functions; see to 6.5.11 in Chapter8)
- 9) Remove the 4 screws [11], detach the copyboard cover open/closed detecting unit [12].

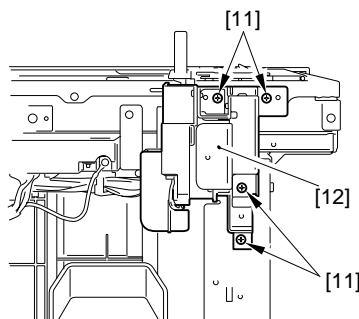

F08-605-09



When mounting the copyboard open/closed detecting unit, be sure to use the black binding screw 3 mm in diameter. Take care not to use the wrong screw.

- 10) Remove the 2 screws [13], detach the humidity preventing plate[14].

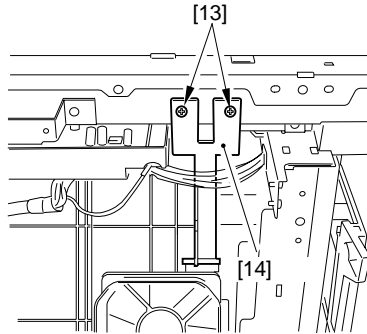

F08-605-10

- 11) Disconnect the 2 connectors [15], and remove the screw [16] of the grounding wire; then, free the harness from the 2 clamps [17].
- 12) Remove the 2 screws [18], and pull the analog processor PCB [19] to the front to detach.
- 13) If you have replaced the PCB, go through the instructions given for replacement (See to 2.3.6 in Chapter13).

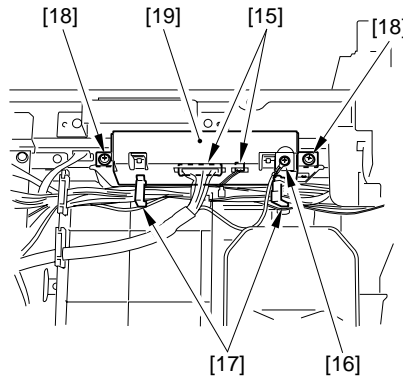

F08-605-11

6.5.8 After Replacing the Analog Processor PCB

Go through the instructions given for the replacement of the analog processor PCB in 2.3.6 of Chapter13.

6.5.9 Removing the Power Supply PCB

- 1) Remove the right cover.
- 2) Disconnect the 4 connectors [1] and the flexible cable [2] from the power supply PCB.
- 3) Remove the 7 screws [3] from the power supply PCB, and detach the power supply PCB [4].

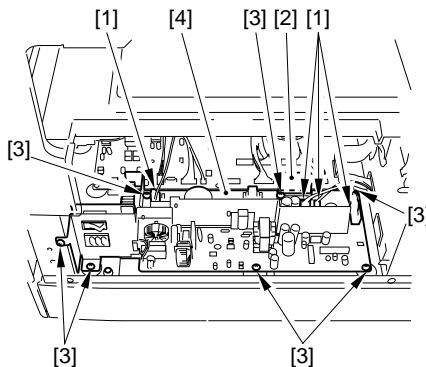

F08-605-12

6.5.10 Removing the Original Detection/Reader Motor PCB

- 1) Remove the rear over.
- 2) Remove the printer board unit. (if equipped with printer functions; see to 6.5.11 in this chapter)
- 3) Disconnect the 7 connectors [1] and the flexible cable [2].
- 4) Remove the 4 screws [3], and detach the original detection/reader motor drive PCB [4].

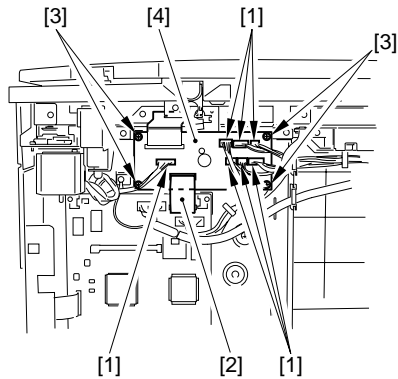

F08-605-13

6.5.11 Removing the Printer Board Unit (if equipped with printer functions)

- 1) Remove the rear cover.
- 2) Disconnect the 2 connectors [1] and the flexible cable [2] from the image processor PCB.
- 3) Remove the 7 screws [3], and detach the printer board unit [4].

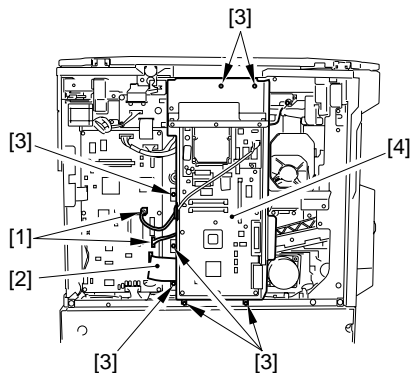

F08-605-14

6.5.12 Removing the Cassette controller PCB (iR2000 only)

See to 4.3.1 in Chapter9.

CHAPTER 9

CASSETTE UNIT

1 Outline

1.1 Outline

The machine may be equipped with a 1-cassette, 3-cassette (for iR1600), or 2-cassette (for iR2000) feeding unit.

1.2 Specifications and Construction

Item	Description
Pickup	Retard method
Paper stack	
1-cassette unit	250 sheets (80 g/m ²)
2-cassette unit	250 sheets x 2 (80/m ²)
3-cassette unit	250 cassette x 3 (80 g/m ²)
Paper size setting	By user
Paper type	Plain, recycled paper (60 to 90 g/m ²)
Paper size	A5/STMT to A3/11 x 17 (279mm x 432mm)
Pickup control	
1-cassette unit	1-cassette unit controller PCB
2-cassette unit	2/3-cassette unit controller PCB
3-cassette unit	2/3-cassette unit controller PCB
Drive source	
1-cassette unit	From main motor of host
2-cassette unit	From pickup motor of cassette unit
3-cassette unit	For cassette 1, from main motor of host; for 2/3 cassette, from cassette pickup motor mounted to 2nd cassette

T09-102-01

1.3 Arrangement of Major Rollers and Sensors

The major rollers and sensors are arranged as follows:

- 1-Cassette Unit

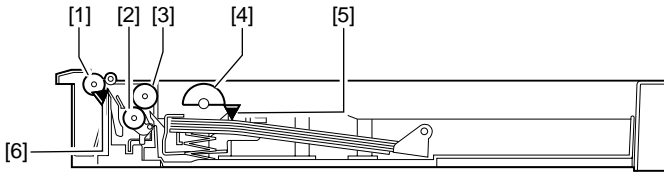

- 2-Cassette Unit

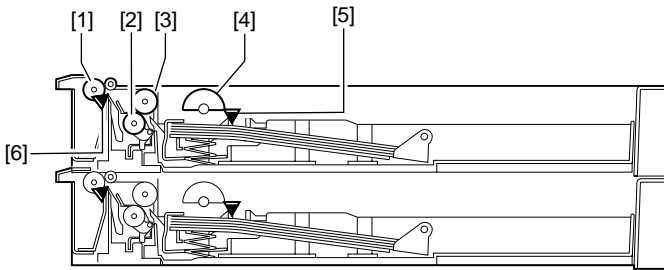

- 3-Cassette Unit

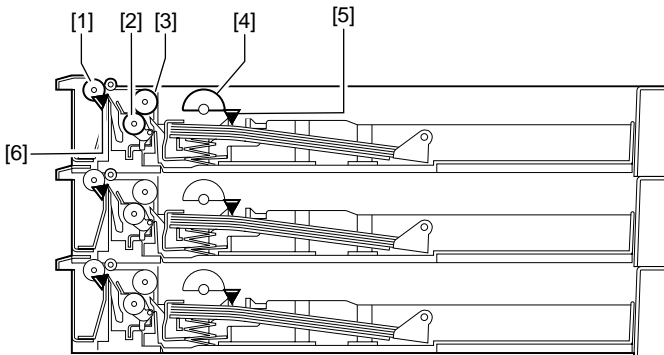

F09-103-01

Ref.	Name
[1]	Vertical path roller
[2]	Separation roller
[3]	Feeding roller
[4]	Pickup roller
[5]	Cassette paper sensor (PS151)
[6]	Re-try sensor (PS152)

T09-103-01

2 Pickup Assembly

2.1 Pickup Control System

The following diagram shows the pickup control system:

- 1-Cassette Unit

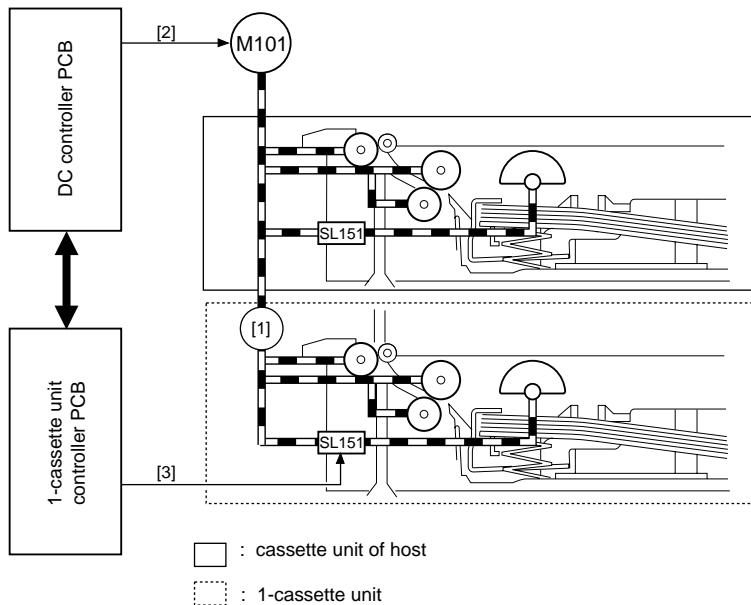

F09-201-01

Ref.	Name
[1]	Link gear
[2]	Main motor drive signal (MTRON)
[3]	Cassette pickup solenoid drive signal (CSTFD)

T09-201-01

• 2-Cassette Unit

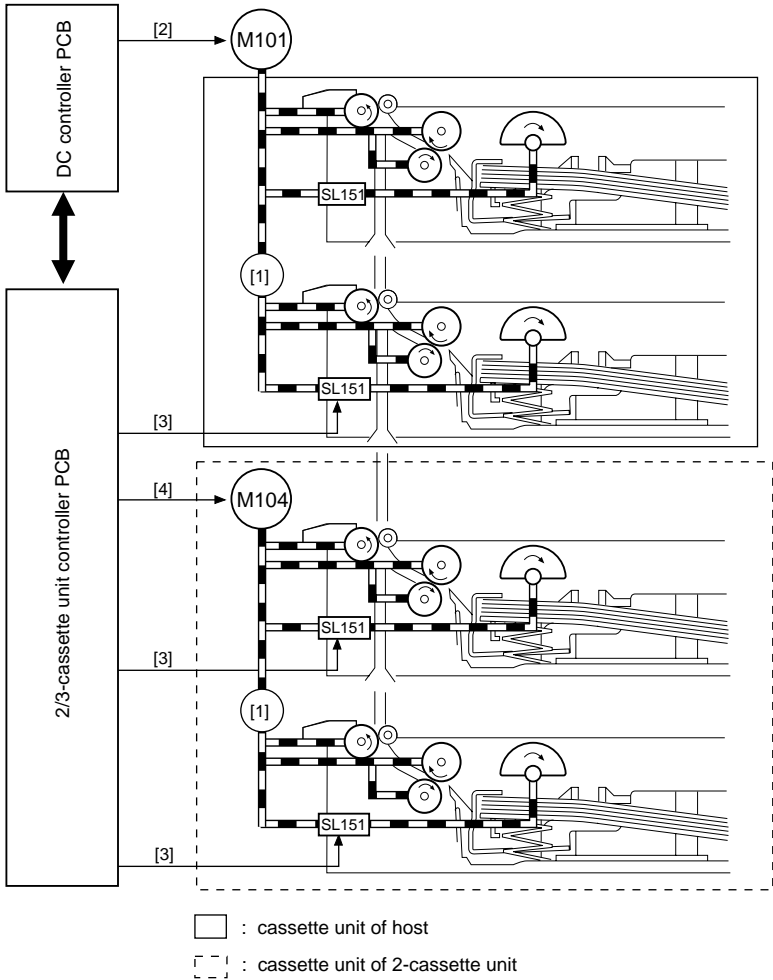

F09-201-02

Ref.	Name
[1]	Link gear
[2]	Main motor drive signal (MTRON)
[3]	Pickup solenoid drive signal (CSTFD)
[4]	Pickup motor drive signal (MTRON)

T09-201-02

• 3-Cassette Unit

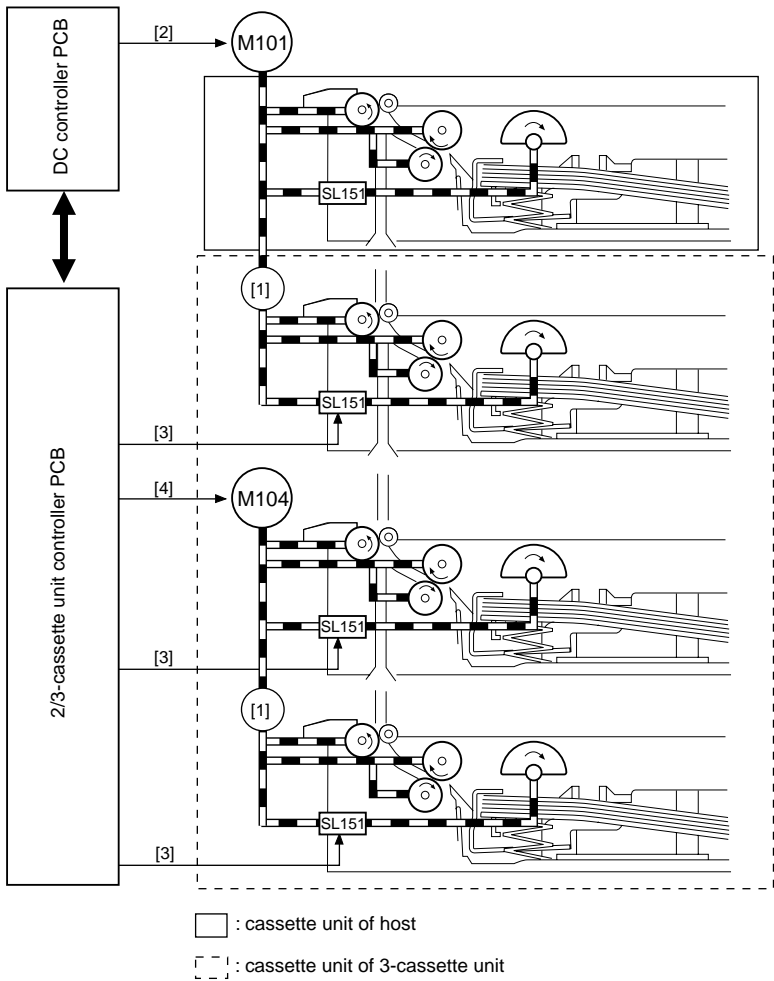

F09-201-03

Ref.	Name
[1]	Link gear
[2]	Main motor drive signal (MTRON)
[3]	Pickup solenoid drive signal (CSTFD)
[4]	Pickup motor drive signal (MTRON)

T09-201-03

2.2 Pickup Control

See 2.1 of Chapter 6.

2.3 Cassette Pickup Operation

See 2.1 of Chapter 6.

2.4 Pickup Re-Try Operation

See 2.1 of Chapter 6.

2.5 Cassette Paper Size Detection

See 2.1 of Chapter 6.

3 Detecting Jams

3.1 Outline

The re-try sensor (PS152) mounted to the cassette unit is used to monitor the movement of paper, and the cassette paper sensor (PS151) is mounted to detect the presence/absence of paper inside the cassette.

The presence/absence of paper is checked at such times as programmed in the CPU of the cassette unit controller PCB; when a jam is detected, the CPU will immediately turn off the main motor (M101) and pickup motor (M104) for the host and indicate the Jam message on the control panel.

3.2 Sequence of Jam Detection

3.1.1 Delay Jam

See 4.2.1 of Chapter 6.

3.1.2 Stationary Jam



See 4.2.2 of Chapter 6.

3.1.3 Jam History

See 4.2.4 of Chapter 6.

4 Disassembly and Assembly

Here, instructions on how to disassemble/assemble the machine are given together with explanations of its mechanical characteristics; be sure to keep the following in mind when going through the work:

1.  Before starting the work, be sure to disconnect the power plug. Moreover, if you have removed the drum unit, be sure to keep it in a protective bag.
2. Unless otherwise specially indicated, reverse the steps used to disassemble the machine when assembling it.
3. Identify the screws by type (length, diameter) and location.
4. To ensure electrical continuity, the mounting screws used for the grounding wire and ar-restors are equipped with toothed washers. Do not leave them out when assembling the machine.
5.  As a rule, do not operate the machine with any of its parts removed.

4.1 Removing the Cassette Unit

- 1) Remove the host cassette and the cassette under it.
- 2) Remove the 4 screws [1], and detach the 2 linking plates [2].

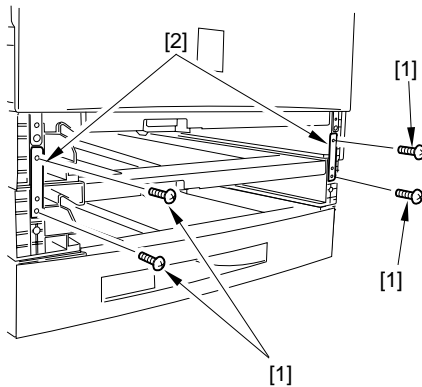

F09-401-01

- 3) Remove the cassette rear cover.
- 4) Remove the 4 screws [3] from the rear of the machine, and detach the 2 link plates [4].

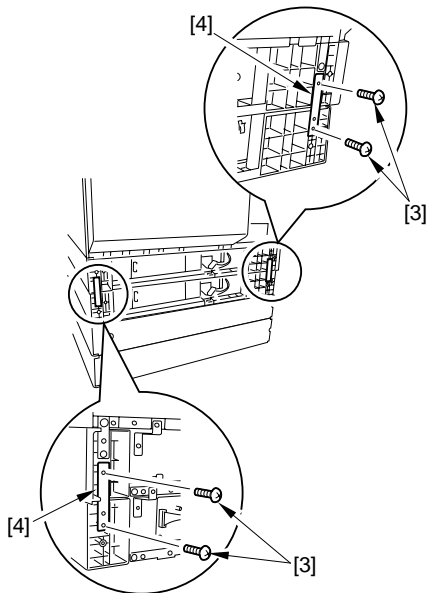

F09-401-02

- 5) Remove the washer screw [5].

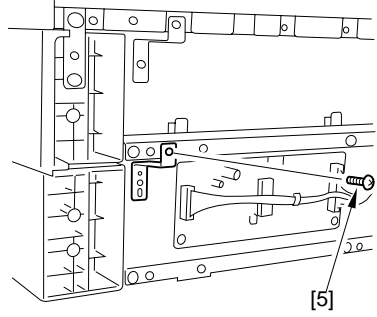

F09-401-03

- 6) Disconnect the connector [6], and free the harness from the guide.

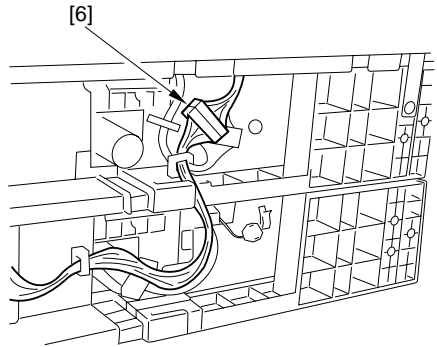

F09-401-04

- 7) Keeping your hands as indicated, detach the host.

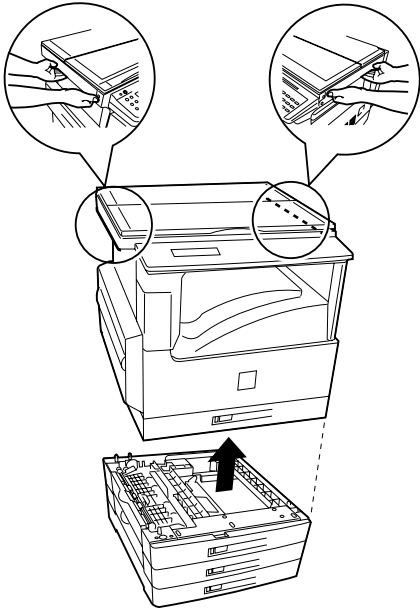

F09-401-05

4.2 Cassette Pickup Assembly

4.2.1 Removing the Cassette Pickup Assembly

See Chapter 6.

4.2.2 Removing the Cassette Pickup Roller

See Chapter 6.

4.2.3 Removing the Cassette Pickup Solenoid

See Chapter 6

4.2.4 Removing the Paper Size Switch

See Chapter 6

4.2.5 Removing the Cassette Paper Sensor

See Chapter 6

4.2.6 Removing the Re-Try Sensor

See Chapter 6.

4.3 PCBs

4.3.1 Removing the Cassette Unit Controller PCB

- 1) Remove the cassette rear cover.
- 2) Remove the 2 screws [1], and disconnect all connectors [2] from the PCB; then, detach the cassette unit controller PCB [3].

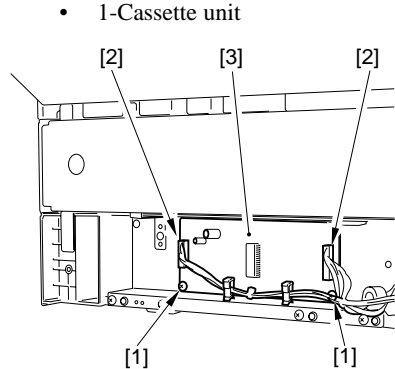

F09-403-01

- 2/3-Cassette unit

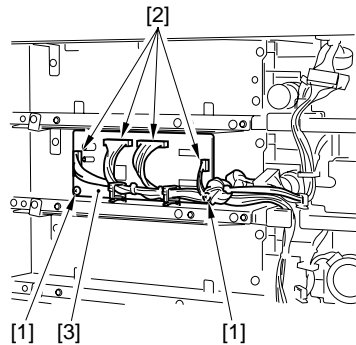

F09-403-02

4.4 Drive-Related Parts

4.4.1 Removing the Pickup Motor

- 1) Remove the cassette rear cover.
- 2) Remove the 4 screws [1], and disconnect the connector [2]; then, detach the pickup motor [3].

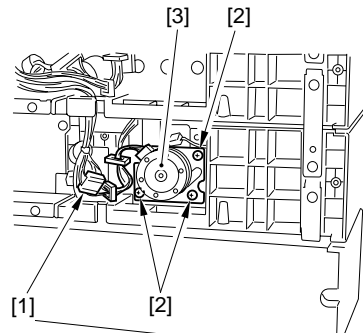

F09-404-01

CHAPTER 10

INNER 2-WAY TRAY

1 Specifications

1.1 System

Item	Description
Number of bins	2 in total 1 bin (No. 2 delivery slot) Host internal delivery tray (No. 1 delivery slot)
Stacking	Face-down
Paper type	Plain, recycled paper (from 60 to 90 g/m ²)
Paper size	A3/279.4 x 431.8mm (11x17 to A5/STMT)
Stack	100 sheets (A4, B5, LTR) 50 sheets (A3, B4, A4R, B5R, 11x17, LGL, LTRR, STMT) 20 sheets (A5R, STMT)
Power supply	DC24V/5V from host

T10-101-01

Names of Trays

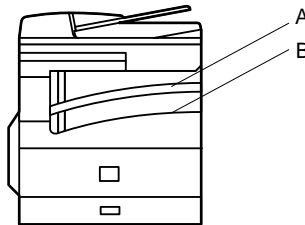

F10-101-01

tray A : No. 2 delivery slot

tray B : No. 1 delivery slot (host)

1.2 Arrangement of Rollers and Sensors

The major rollers and sensors of the inner 2-way tray are arranged as follows:

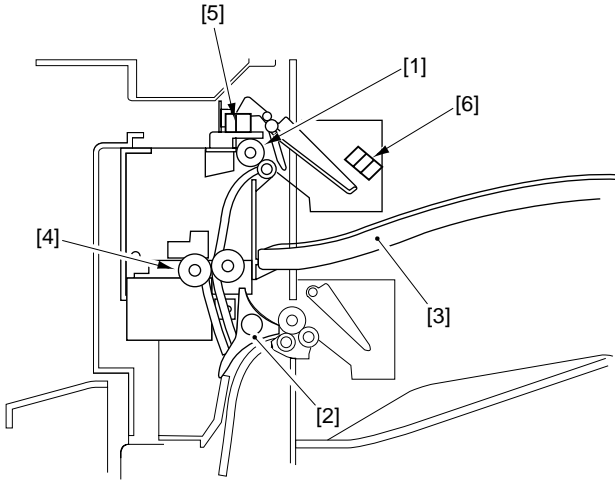

- [1] No. 2 delivery roller
- [2] Delivery flapper
- [3] No. 2 delivery tray
- [4] No. 2 delivery roller
- [5] No. 2 delivery sensor
- [6] No. 2 full detection sensor

F10-102-01

2 Controlling Delivery Operation

2.1 Controlling Delivery Operation

Paper is delivered to the No. 2 delivery slot as follows:

When paper is fed from the host's fixing assembly and its leading edge reaches the delivery sensor (PS103), the 2-way delivery solenoid (SL201) goes ON to switch the paper path to the No. 2 delivery slot.

The paper being moved is detected by the delivery sensor (PS201).

The volume of paper in the delivery tray is monitored by the No.2 full detection sensor (PS202).

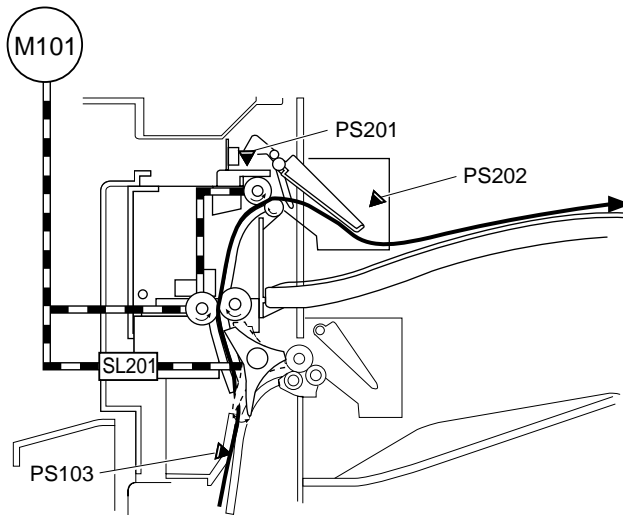

F10-201-01

2.2 Selecting a Delivery Slot (user mode)

Delivery tray A or delivery tray B may be selected for a specific type of output (copies, prints) when installing the inner 2-way tray.



user mode>01 COMMON SETTINGS>07 TRAY SETTINGS>TRAY A,
TRAY B

3 Detecting Jams

3.1 Outline

The No. 2 delivery sensor mounted to the inner 2-way tray is used to monitor the movement of paper.

The presence/absence of paper is checked in relation to the presence/absence of paper over a specific sensor at such times as programmed in the CPU of the DC controller PCB. If a jam is detected, the CPU will immediately turn off the host's main motor (M101) and indicate the Jam message in the control panel.

3.2 Sequence of Jam Detection

3.2.1 Delay Jam

See 4.2.1 of Chapter 6.

3.2.2 Stationary Jam



See 4.2.2 of Chapter 6.

3.2.3 Jam History

See 4.2.4 of Chapter 6.

4 Disassembly and Assembly

Here, instructions on how to disassemble/assemble the machine are given together with explanations of its mechanical characteristics; be sure to keep the following in mind when going through the work:

1.  Before starting the work, be sure to disconnect the power plug. Moreover, if you have removed the drum unit, be sure to keep it in a protective bag.
2. Unless otherwise specially indicated, reverse the steps used to disassemble the machine when assembling it.
3. Identify the screws by type (length, diameter) and location.
4. To ensure electrical continuity, the mounting screws used for the grounding wire and arrestors are equipped with toothed washers. Do not leave them out when assembling the machine.
5.  As a rule, do not operate the machine with any of its parts removed.

4.1 Removing the Inner 2-Way Unit

- 1) Remove the left cover.
- 2) Remove the drum unit (See to 7.1.1 in Chapter 5).
- 3) Remove the multifeeder tray.
- 4) Remove the left rear cover.
- 5) Remove the 2 screws [1], and detach the left front cover [2]; then, detach the inner deliver upper cover [3].

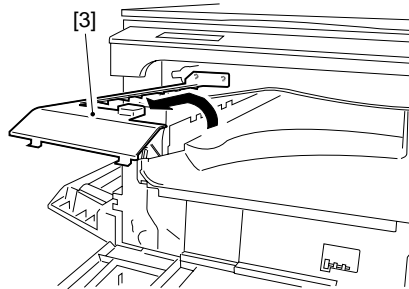
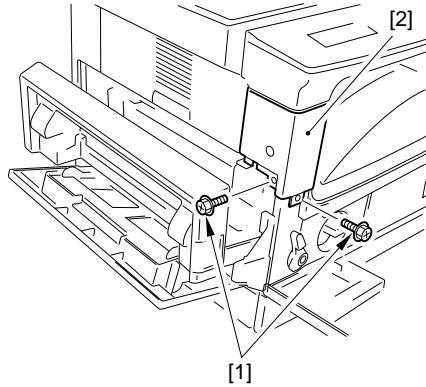

- 6) Open the front cover, and remove the 5 screws [4]; then, detach the right cover [5].
- 7) Remove the 2 screws [6], and detach the delivery tray [7].

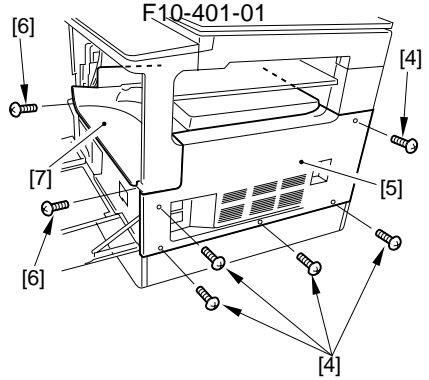

- 8) Remove the inner delivery tray [8].

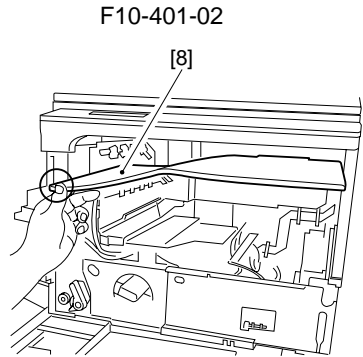

- 9) Detach the fixing connector cover [9] as shown.

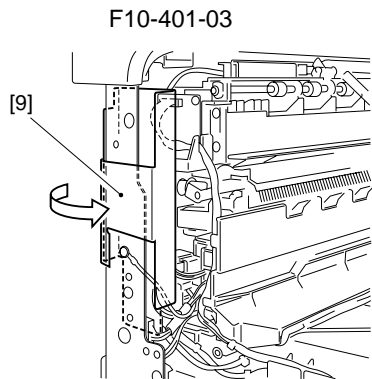

F10-401-04

10) Disconnect the connector [10] of the inner 2-way tray PCB; then, free the harness from the harness guide.

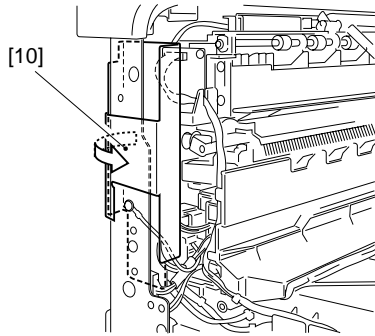

11) Remove the 2 screws [11], and remove the fixing connector fixing plate [12] and the grounding wire [13].

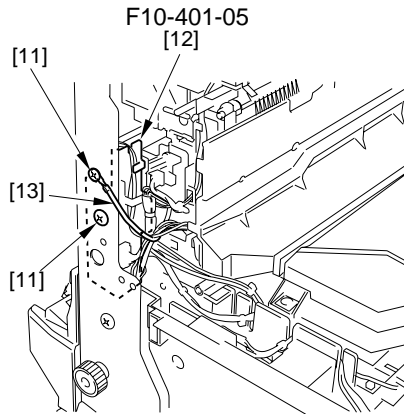

12) Disconnect the 3 connectors [14] from the fixing connector fixing plate, and free the harness from the harness guide.

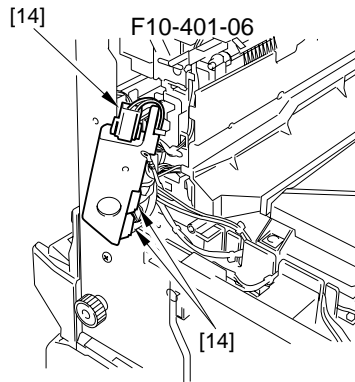

- 13) Open the fixing cover, and remove the 6 screws [15]; then, detach the fixing unit [16].

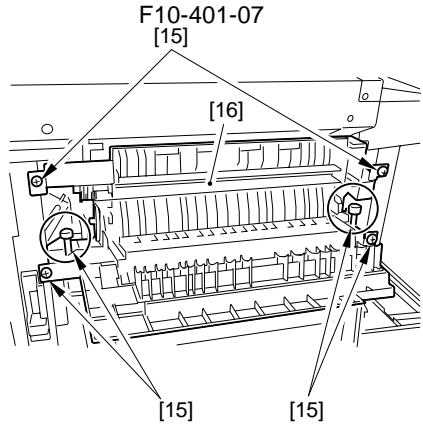

F10-401-08



1. For the screw inside the circle, be sure to use a hex wrench (less than 2 mm).
2. When removing the fixing assembly, be sure to hold it as shown. Be sure not to impose force on the sensor lever [17].

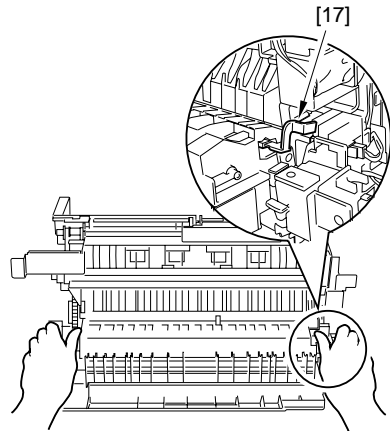

- 14) Remove the inner delivery gear [18], feeding roller drive belt [19], and pulley flange [20] of the fixing assembly.

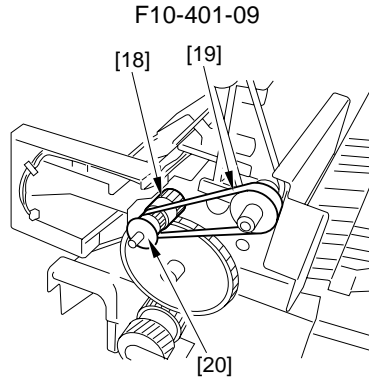

- 15) Remove the solenoid pin [21] used to link the solenoid arm and the plunger.

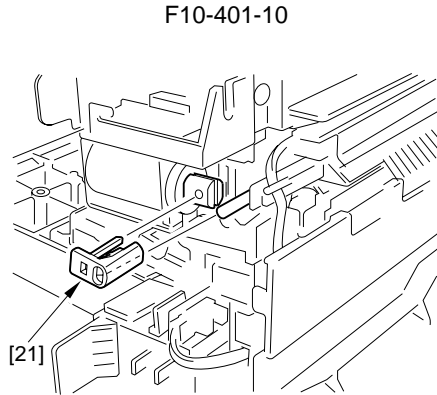

16) Remove the 2 screws [22], and detach the inner 2-way solenoid [23].

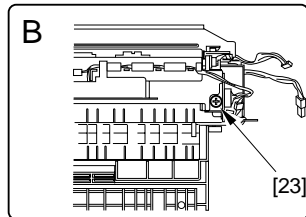
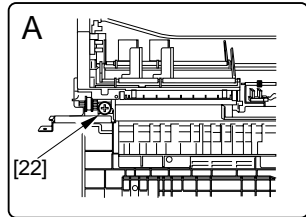
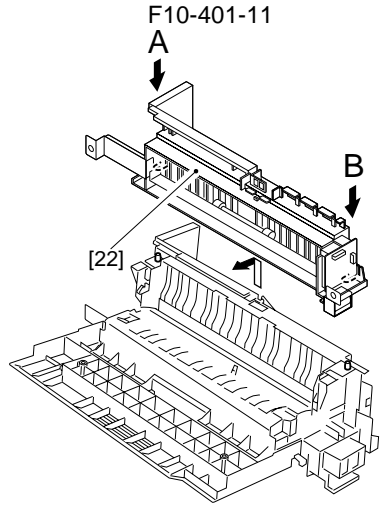

F10-401-12

CHAPTER 11

INSTALLATION

1 Selecting the Site of Installation

The site must meet the following requirements; if possible, visit the user's before the delivery of the machine:

1. There must be a power outlet that may be used exclusively for the machine and rated as indicated ($\pm 10\%$).



Do not use piping used for gas services to connect the grounding wire.

2. The site must be between 15° and 30°C (59° to 86°F) in temperature and between 10% and 80% in humidity. Avoid areas near a water faucet, water boiler, humidifier, and refrigerator.
3. Avoid areas near a source of fire or areas subject to dust or ammonium gas. If exposed to direct rays of the sun, provide curtains.
4. The level of ozone generated by the machine in sue should not affect the health of the individuals around it. Some, nevertheless, find the odor unpleasant, requiring adequate ventilation of the room.
5. The machine must remain level, its feet fully in contact with the floor.

6. The following are the spatial requirements, determined in view of maintenance work:

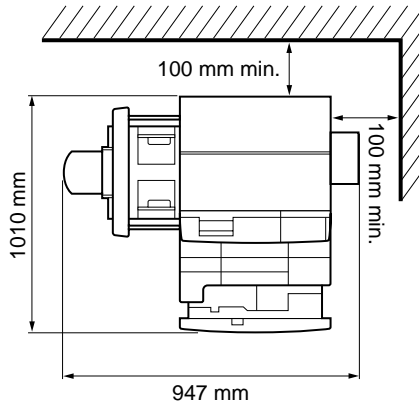

F11-101-01

7. The machine must be installed in a well-ventilated area. Be sure, however, not to install the machine near any air vent of the room.

2 Unpacking and Installing the Machine

2.1 Points to Note Before Starting the Work

Be sure to keep the following in mind for the work:



-
1. If machine is moved from a cold to warm place, condensation can develop in its pickup/feeding assembly. If such a possibility exists, leave the machine alone for 1 hr or longer, and start the work after it has become used to the temperature of the room.
(The term condensation is used to refer to the development of droplets of water on the surface of a metal piece, occurring when it is brought from a cold to warm place because of the rapid cooling of the water vapor around the metal.)
 2. Be sure to work as a group of two.
-

2.2 Installing the Machine

Install the machine in the following sequence; for details, see the e pages that follow:

- 1) unpacking and removing of the fixing members
- 2) installing the dummy drum
- 3) removing the dummy drum
- 4) supplying toner
- 5) placing paper in the cassette
- 6) placing paper in the multifeeder tray
- 7) checking the copy images
- 8) Data initialization through service operation
- 9) setting the date/time
- 10) storing the specifications report

2.3 Unpacking and Removing the Fixing Members

- 1) Unpack the machine, and take out the attachments; check to be sure that none of the following is missing:
 - power cord
 - cassette size label
 - paper size indicating plate
 - warnings sheet
 - toner cartridge (May be packed separately depending on the destination.)
 - drum unit
 - User's Manual

- 2) Holding the grips on the left and right of the machine, take out the machine. (Be sure to work as a group of two.)

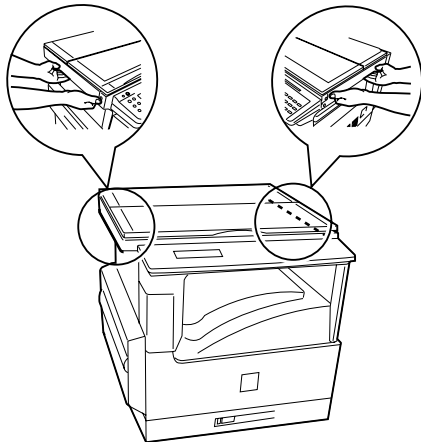

F11-203-01

- 3) Unpack the machine, and remove the plastic cover, cushioning material, and tape.
- 4) Remove the CS fixing screw [1]. Open the front cover, and store the removed screw [2] in the storage area.

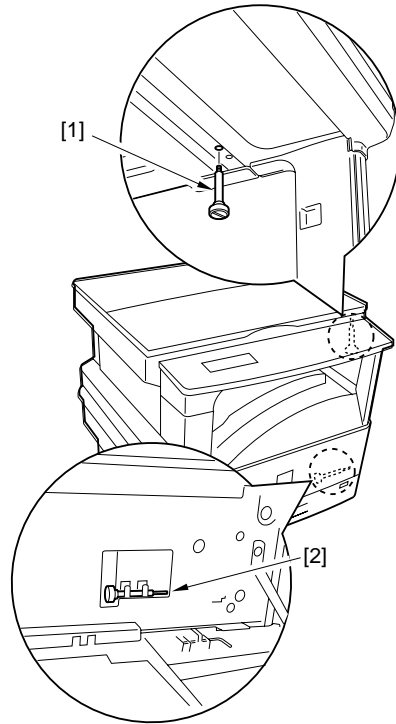

F11-203-02

2.4 Removing the Dummy Drum

- 1) Open the front cover, and remove the tape.
- 2) Turn the developing assembly locking lever [1] clockwise to unlock.

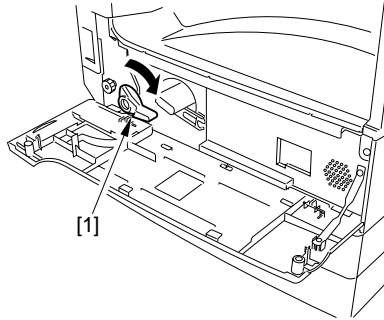

F11-204-01

- 3) Open the multifeeder tray [2], and pull the grip [3] to slide out the left cover [4].

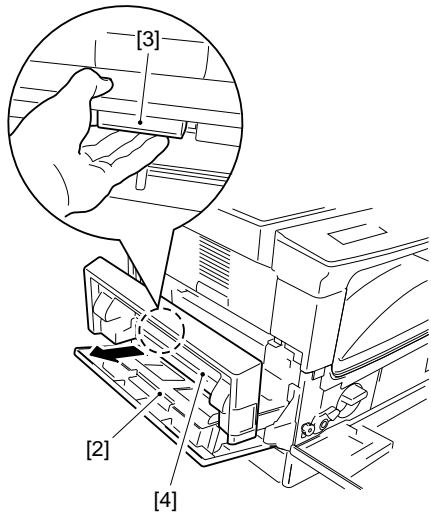

F11-204-02

- 5) Remove the tape [5] used to keep the transfer charging roller in place.

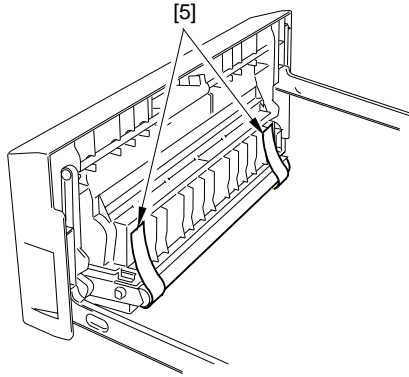

F11-204-03

- 4) Remove the tape, and remove the dummy drum [6] fitted to the machine.

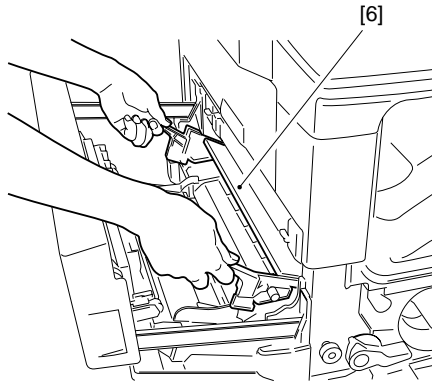

F11-204-04

2.5 Mounting the Drum Unit

- 1) Remove the 2 fixing members [1] used to keep the developing assembly in place.

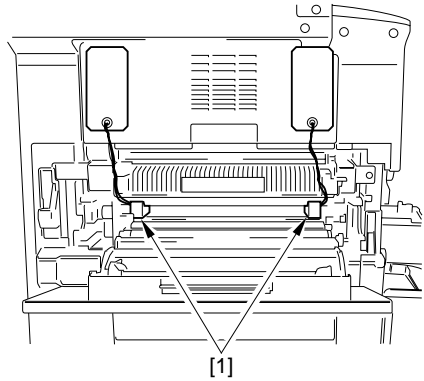

F11-205-01

- 2) Unpack the drum unit, and remove the air-bubble sheet [2].

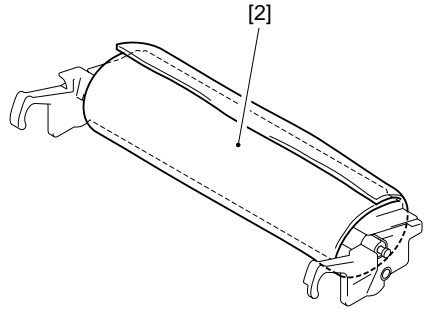

F11-205-02



At this time, do not remove the packing tape [3] used to protect the drum.

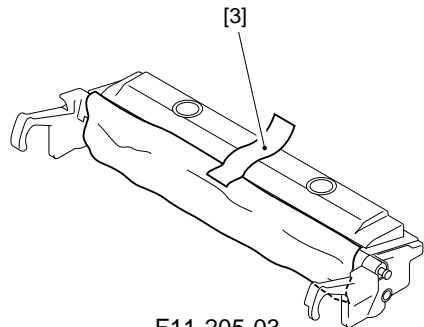

F11-205-03

- 3) Holding the grips [4] of the drum unit with both hands, fit the drum unit [5] into the machine. At this time, take the packing tape outside the machine.

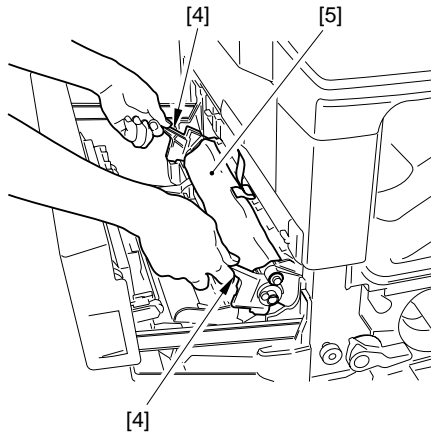

F11-205-04

- 4) Then, remove the packing tape [6] of the drum protection sheet, and remove the drum protective sheet [7].

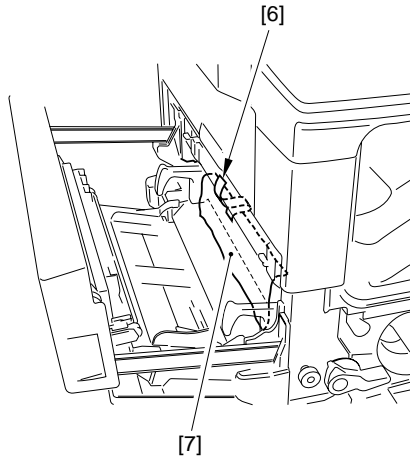

F11-205-05

2.6 Mounting the Toner Cartridge

- 1) Remove the fixing tape [1] shown in the figure.

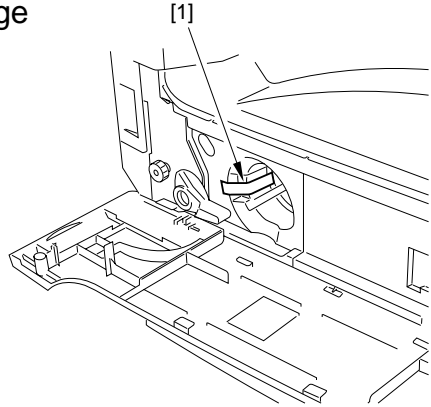

F11-206-01

- 2) Unpack the toner cartridge.
- 3) Holding the grip [2] of the toner cartridge, fit it while holding down the lever [3] and keeping the taped face upward.



Check to be sure that it has been fully fitted into the machine.

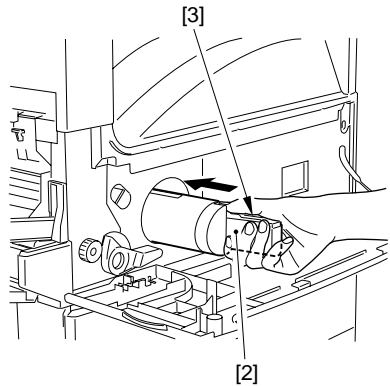

F11-206-02

- 4) Holding the grip [4] of the toner cartridge, pick the tab [5] of the tape, and pull the tape out horizontally.

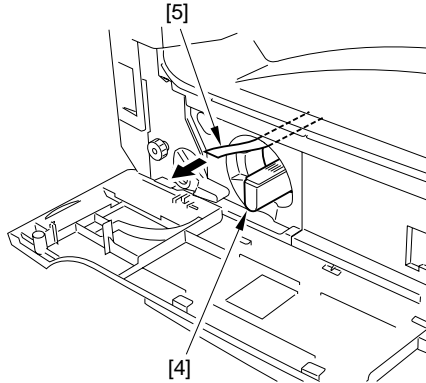

F11-206-03

- 5) While holding the grip lever [6], turn it counterclockwise.

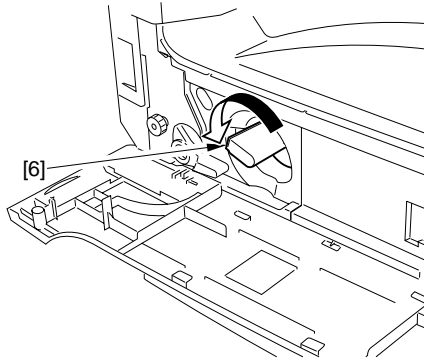

F11-206-04

- 6) Turn the developing assembly locking lever [7] counterclockwise to lock it in place.

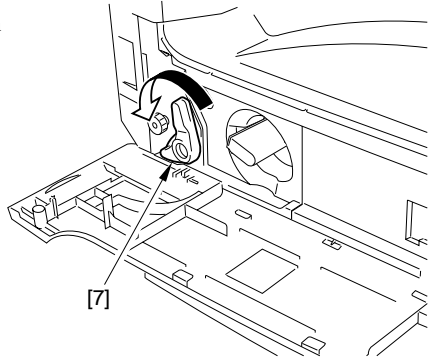

F11-206-05

- 7) Mount the left cover, and close the front cover.
- 8) Close the multifederer tray.

2.7 Putting Paper in the Cassette

- 1) Holding the grip [1] in the center of the cassette, slide out the cassette [2] until it stops.

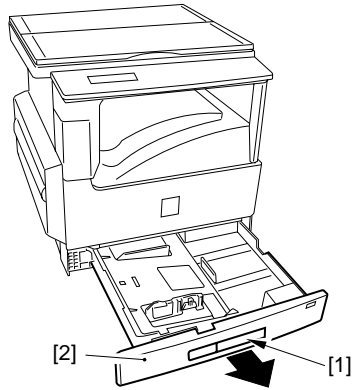

F11-207-01

- 2) Remove tapes and the cable band [3] used to keep the holding plate of the cassette in place.

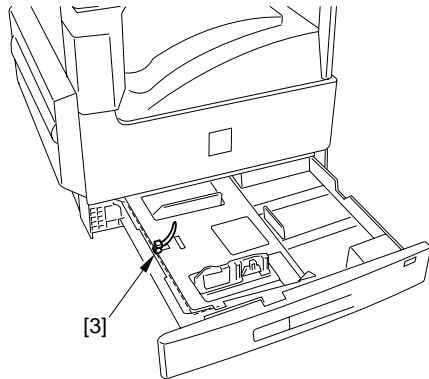

F11-207-02

- 3) Lightly press the area indicated with a marking [4] on the holding plate [5] of the cassette to lock the holding plate in place.

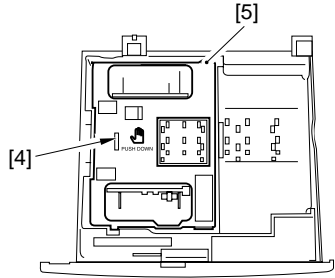

F11-207-03

- 4) Turn the tab [6] of the front of the paper width guide to release the lock; then, slide the guide [7] to suit the width of paper to use, and turn other tab once again to lock it in place.

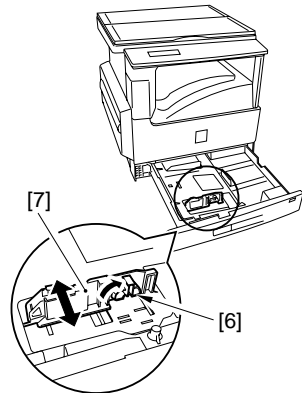

F11-207-04

- 5) Shift the paper trailing edge guide plate [9] to detach while referring to the \triangle marking [8] of the guide plate.

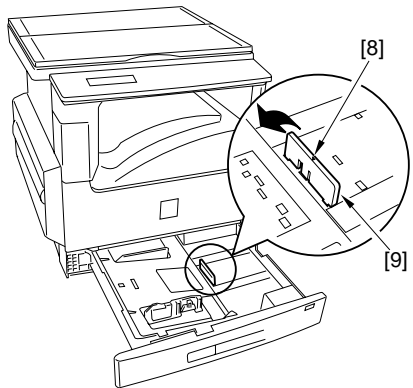

F11-207-05

- 6) As if to reverse the steps used for removal, fit the paper trailing edge guide plate [10] to suit the size of paper to use.

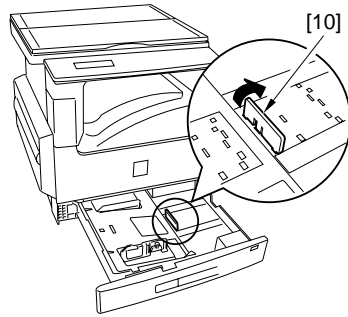

F11-207-06

- 7) Set the paper size detecting lever [11] to suit the size of paper to use.

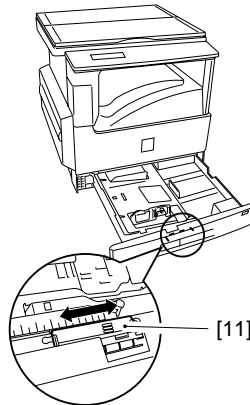

F11-207-07

- 8) Remove the plastic protective sheet of the paper size indicating plate [12], and attach the cassette size label [13] for the size of paper to use; then, set the indicating plate to the cassette.

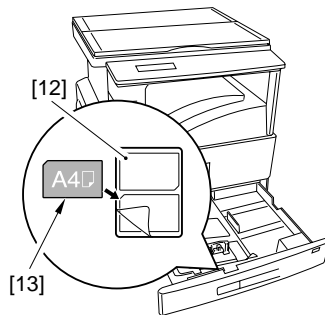

F11-207-08

- 9) With the side indicating the language of choice in view, attach the warnings sheet [14].

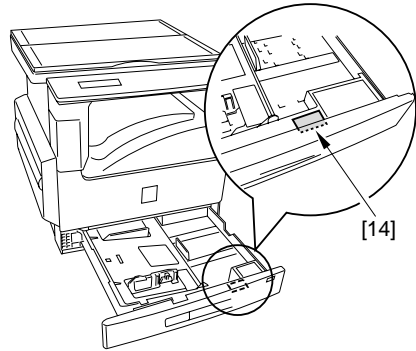

F11-207-09

- 10) Keeping the left/right and leading edges of the sheets [15] flush, place the stack of paper in the cassette.



When the cassette is slid into the machine, the lock will automatically be released if its holding plate locked it. If the lock of the holding plate is released, press the marking **PUSH DOWN** lightly before placing paper.

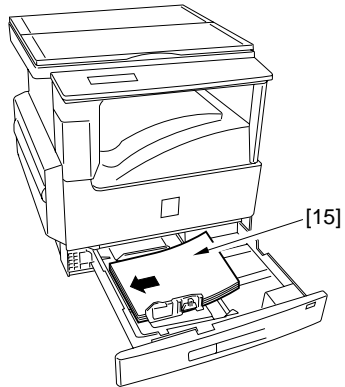

F11-207-10

- 11) Check to make sure that the claws [16] of the cassette are positioned to retain both edges of the paper.

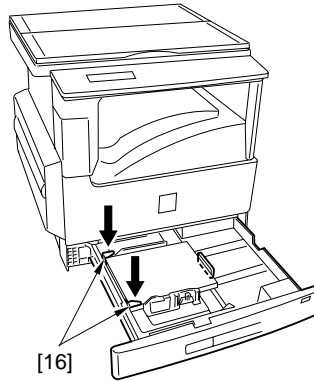

F11-205-11

- 12) Holding the grip in the middle of the cassette, fit the cassette in the machine until it stops, while taking care not to push one side of the cassette ahead of the other.

2.8 Placing Paper in the Multifeder Tray

- 1) Open the multifeder tray [1].

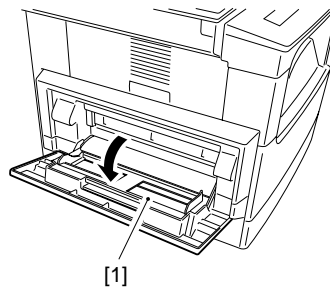

F11-208-01

- 2) Set the paper width guide [2] and the auxiliary guide [3] to suit the width and the length of paper to use.

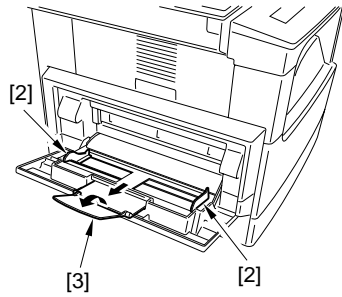

F11-208-02

- 3) Keeping the left and right edges of the sheets [4] flush, place the stack of paper in the multifeder tray. Adjust the paper width guide to suit the width of paper.



Do not force the paper width guide against the paper.

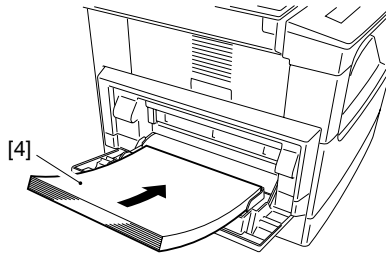

F11-208-03

2.9 Checking the Copy Images

- 1) Connect the power cord to the AC outlet, and turn on the power.



The power supply must be as rated. (The voltage may be \pm 10% of the rating, but it must have the rated amperage.)

- 2) Place an original on the copyboard glass, and make copies in cassette and manual feed modes; then, check the copy images. Also, make sure of the following:
 - There is no abnormal noise.
 - The image quality of copies made at each default ratio is normal.
 - As many copies as specified are made normally.

2.10 Data Initialization through Service Operation

- 1) Press the Additional Functions key and the ID (#) key in sequence to bring up the Service Mode screen.



SERVICE MODE
#1 SSSW

F11-210-01

- 2) Using the cursor key ◀▶, select '#12 CLEAR', and press the OK key so that the #12 CLEAR screen will appear.



SERVICE MODE
#12 CLEAR

F11-210-02

- 3) Using the cursor key ◀▶, select 'ALL', and press the OK key so that a all clear will be executed.
- 4) The machine will automatically bring up the Copy screen.
- 5) Press the Additional functions key and ID (#) key in sequence to bring up the Service Mode screen.
- 6) Using the cursor key, select '#5 TYPE', and press the OK key so that the #5 TYPE screen will appear.
- 7) Be sure to ensure that you set the country type to suit the communication standard used in your country/region using the cursor key.
- 8) Press the OK key so that the entered type settings will be stored.
- 9) Press the clear key to return the copying mode.

2.11 Setting the Date/Time (user mode)

- 1) Press the Additional Functions key to bring up the User Mode screen.
- 2) Using the cursor key ◀▶, select '3. TIMER SETTINGS', and press the OK key.
- 3) Using the cursor key ◀▶, select '1. DATE/TIME SETTING', and press the OK key so the currently used date/time is indicated.
- 4) Enter the current date/time. Move the cursor key ◀▶ to the appropriate characters, and enter numerals.

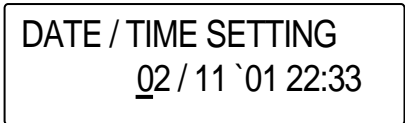

F11-211-01

- 5) Press the OK key so that the entered date/hour will be stored.
- 6) Press the clear key to return the copying mode.

2.12 Storing the Specifications Report

- 1) Press the Additional Functions key and the ID (#) key in sequence to bring up the Service Mode screen.

SERVICE MODE
#1 SSSW

F11-212-01

- 2) Using the cursor key ◀▶, select '#10 REPORT', and press the OK key so that the #10 REPORT screen will appear.

SERVICE MODE
#10 REPORT

F11-212-02

- 3) Using the cursor key ◀▶, select '8. PRINT SPEC REPORT', and press the OK key so that a specifications report will be generated.

SERVICE REPORT
8. PRINT SPEC REPORT

F11-212-03

- 4) Open the front cover, and fold the generated report [1]; then, store it away between the front cover and the jam removal instructions sheet. (Free the jam instructions sheet from the claw before fitting in the report.)

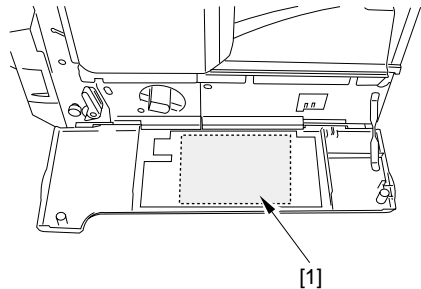

F11-212-04

- 5) Clean up the area around the machine.

2.13 Checking the Printer Functions (if equipped with printer functions)

- 1) Turn on the machine.
- 2) Press the System key in the control panel, and check to see that the LED of the key has gone ON. ('READY' will be indicated on the display; otherwise, check to be sure that the printer board has been mounted properly.)
- 3) Execute the 'TEST PRINT' as follows to make sure that printing is normal:
 1. Press the System key in the control panel (so that the LED of the key goes ON).
 2. Press the GO key so that the machine will be in off-line state. ('PAUSE' will be indicated on the display.)
 3. Press the menu key. ('TEST MENU' will be indicated on the display.)
 4. Select 'TEST PRINT' using the Item key, and press the Enter key to start test printing.
- 4) Check to see that the name and the version of the printer board are indicated on the generated test print.
- 5) Turn off the machine, and connect the network cable.
- 6) Turn on the machine.
- 7) Inform the user's system administrator that the machine has been installed, and ask him/her to make network settings.

3 Relocating the Machine

If you must relocate the machine by truck or other means of transportation after the installation of the machine, perform the following:

1. Remove all paper from the cassettes.
2. Turn off the power, and disconnect the power plug from the power outlet.
3. Start service mode, and execute '#14 CS SET' so that the carriage moves to home position. Using the fixing screw stored on the front cover, secure the carriage in place from under the reader.
- Check to make sure that the carriage will not move.
4. Take out the drum unit. Put the drum unit in a protective bag, and carry it separately.
5. Take out the developing assembly, and carry it separately.
6. The transfer charging roller can become displaced in transit. Be sure to fix it in place with tape [1] as shown. (At that time, wrap the gear assembly with lint-free paper to keep it from glue.)
7. Tape the covers and cassette in place.
8. If the machine is equipped with an ADF, place A3 or 11x17 copy paper on the copyboard glass, and tape the ADF in place.

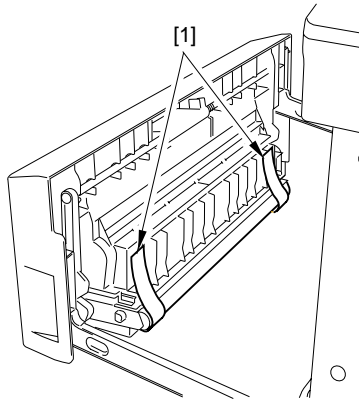

F11-301-01

4 Installing the Card Reader-E1 (accessory)

4.1 Points to Note for Installation

For installation, be sure to obtain the following:

- 1) Card Reader
 - Attachment
 - [1] Card reader
 - [2] Harness
 - [3] Screw
 - [4] Omega lock

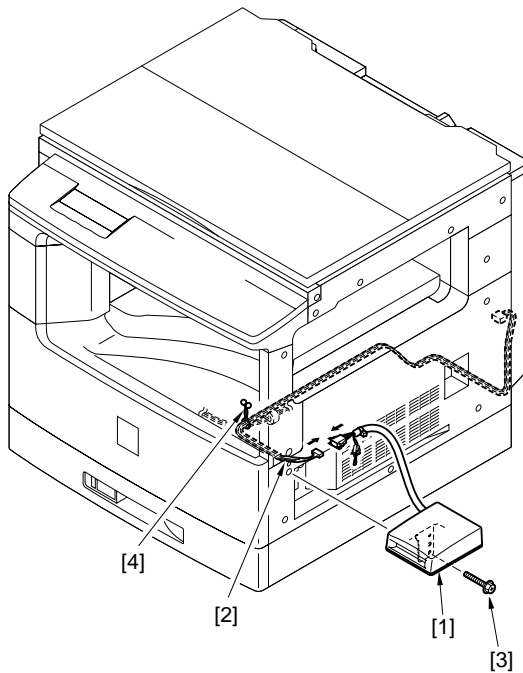

F11-401-01

4.2 Installation

- 1) Remove the 7 screws [1], and detach the rear cover [2].

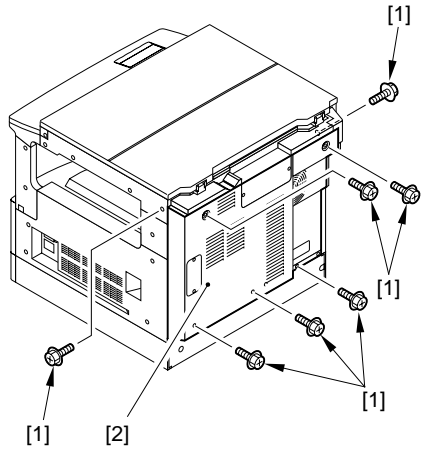

F11-402-01

- 2) Remove the 5 screws [3], and detach the right cover [4].

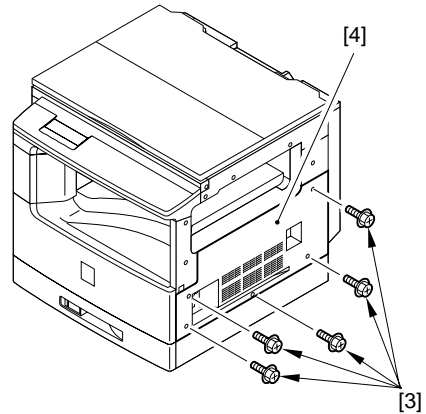

F11-402-02

- 3) Cut the dummy cover area [5] of the right front support with nippers.

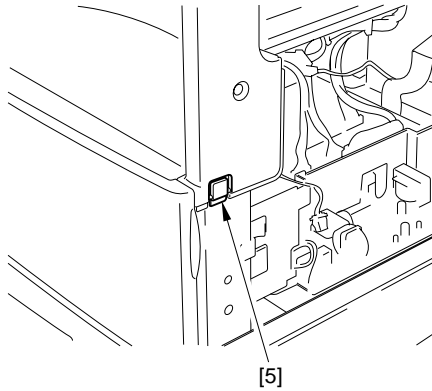

F11-402-03

- 4) Connect the connector [7] of the harness [6] that comes with the unit to J210 of the image processor PCB.
- 5) Route the harness [6] as indicated, and lead it through the opening [8].

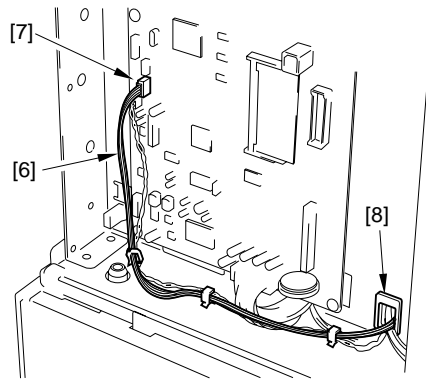

F11-402-04

- 6) Lead the harness [6] routed from the rear through the clamp and the guide, and then, lay it as indicated.
- 7) Fit the omega lock [9] that comes with the unit as indicated, and twist its both ends and fix it to the harness.

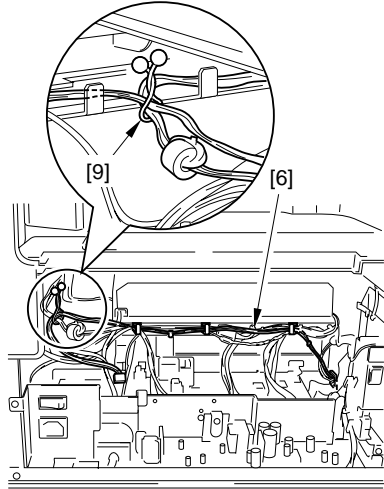

F11-402-05

- 8) Route the harness [6] farther as indicated.



Be sure to keep the connector [10] for the harness out of the hole [11] as indicated.

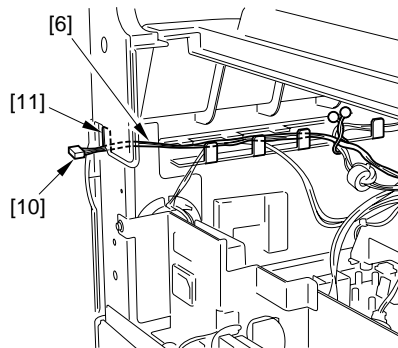

F11-402-06

- 9) Mount the removed right cover, rear cover, and right rear cover. (At this time, do not tighten the screw at [14].)



When mounting the right cover, take care so that the connector of the harness will not be inside the machine.

- 10) Connect the connector [10] of the routed harness and the connector [12] of the card reader.



Be sure to remove the shorting connector [13]; otherwise, an operation fault or error can occur.

- 12) Using the screw [14] that comes with the unit, mount the card reader [15].

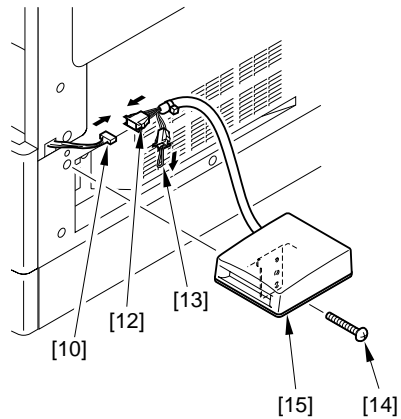

F11-402-07

5 Installing the Image RAM (accessory)

5.1 Installation

- 1) Remove the 7 screws [1], and detach the rear cover [2].

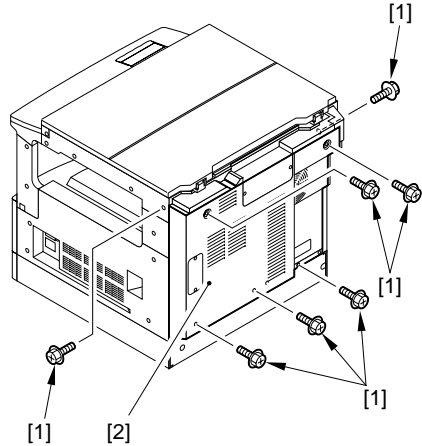

F11-501-01

- 2) Mount the RAM DIMM [4].



Take care not to damage the elements and the like.

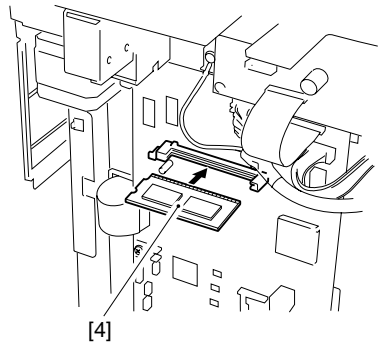

F11-501-02

- 3) Mount the removed rear cover.
- 4) Press the Additional Functions key and the ID (#) keys in sequence to start service mode.
- 5) Using the cursor key ◀▶, select 'TEST MODE', and press the OK key to start test mode.
- 6) Press '1' on the keypad so that '1: D-RAM' is indicated.
- 7) Check to be sure that the LCD indicates the new RAM size.
- 8) Press the Stop key and then the Clear key to end test mode.

CHAPTER 12

MAINTENANCE AND INSPECTION

1 Periodically Replaced Parts

Some parts of the machine require periodical replacement to ensure a specific level of machine performance (i.e., once they fail, the machine performance will be affected significantly).

If possible, plan the replacement to coincide with a scheduled service visit.



The data given is for reference only, and is subject to the site environment and characteristics of use.

1.1 Copier

The copier does not have parts that require periodical replacement.

1.2 Cassette Unit

The cassette unit does not have parts that require periodical replacement.

1.3 Inner 2-Way Tray

The inner 2-way tray does not have parts that require periodical replacement.

2 Guide to Durables

Some durables of the machine require replacement once or more over the life of the product because of wear or damage. Replace them when they fail.

2.1 Checking the Timing of Replacement

Check the timing of replacement in service mode as follows:

- 1) Start service mode, and make the following selections: #9 COUNTER>DRBL-1; then, press the OK key.
- 2) Select the appropriate item using the cursor key, and press the OK key to check the counter reading.

2.2 Copier

As of September 2001

No.	Parts name	Parts No.	Q'ty	Life	Remarks
1	Fixing roller	FB5-8132	1	150,000 copies	Actual copies made.
2	Pressure roller	FB6-1549	1	150,000 copies	Actual copies made.
3	Fixing roller bushing	FB6-1548	2	150,000 copies	Actual copies made.
4	Separation claw	FB5-8143	5	150,000 copies	Actual copies made.
5	Developing assembly	FG6-8413	1	150,000 copies	Actual copies made.
6	Transfer charging roller	FB5-8019	1	150,000 copies	Actual copies made.
7	Multifeeder separation pad	FB5-8028	1	50,000 copies	Actual copies made.
8	Multifeeder pickup roller	FF6-1671	1	50,000 copies	Actual copies made.

T12-202-01

2.3 Cassette Unit

The cassette unit does not have parts that are referred to as durables.

2.4 Inner 2-Way Tray

The inner 2-way tray does not have parts referred to as durables.

3 Basic Service Work

3.1 Basic Service Work

The machine does not have an item that requires periodical service. Nevertheless, the following work is recommended to ensure a longer product life.

As of September 2001

Work Procedure

1. Report to the person in charge, and check the general condition.
2. Correct any fault.
3. Make test copies, and check the following; if a fault is found, correct it:
 - 1) image density (against standard)
 - 2) background (for soiling)
 - 3) characters (for clarity)
 - 4) fixing, registration (for displacement), back (for soiling)
 - 5) margin (against standards; see the following)
4. Clean the parts (See to 4. of Chapter 12).
5. Make test copies.
6. Clean up the area around the machine.



Memo

Standards for Print Accuracy

Make test copies using plain paper, and check to make sure that the following are true:

image leading edge margin : 3.0 ± 1.5 mm

left margin : 3.0 ± 2.0 mm

right margin : 0.5 mm or more

If not, make adjustments by referring to 2 of Chapter 13.

4 Cleaning During a Visit

Perform the following during a visit to the user's:

1. Copyboard Glass, Reading Glass, and Back of the Copyboard Cover (retainer)

Open the copyboard cover, and wipe the parts with a cloth moistened with water (well wrung); then, wipe them with a soft, dry cloth.

2. Contact Sensor

Remove the 2 screws, and detach the copyboard glass; then, remove any dirt from the lens array of the contact sensor with a soft, dry cloth.



-
1. The contact sensor is vulnerable to static charges. Be sure to take preventive measures before cleaning it.
 2. Do not touch or wipe the glass (photoconductor) around the lens assembly.
 3. Do not use water or solvent.
-

3. Cassette Pickup Roller

- 1) Slide out the cassette, and open the left lower cover.
- 2) Turn the pickup roller by hand so that the roller faces downward; then, insert a screwdriver to the pickup roller shaft from the left lower cover side, and keep the roller in place.
- 3) Remove the pickup roller, clean it with lint-free paper. If the dirt is excessive, use alcohol.

4. Feeding Roller, Separation Roller, and Vertical Path Roller

- 1) Open the left lower cover, and clean the roller with lint-free paper while turning the roller by hand. If the dirt is excessive, use alcohol.

5. Manual Feed Pickup Roller

- 1) Open the manual feed tray, and remove the left cover.
- 2) Open the front cover, and release the developing assembly lever; then, detach the drum unit.
- 3) Remove the multifeeder tray and the pickup guide (2 screws); then, detach the manual feed pickup roller.
- 4) Clean the roller with lint-free paper. If the dirt is excessive, use alcohol.

6. Manual Feeding Separation Pad

- 1) Open the multifeeder tray, and detach the left cover.
- 2) Open the front cover, and release the developing assembly lever; then, detach the drum unit.
- 3) Remove the multifeeder tray and the pickup guide (2 screws); then, clean the manual feed serration pad with lint-free paper.

7. Registration Roller

- 1) Open the multifeeder tray, and detach the left cover.
- 2) Open the front cover, and release the developing assembly lever; then, detach the drum unit.
- 3) Remove the multifeeder tray and the pickup guide (2 screw); then, clean the roller with lint-free paper while turning it by hand. If the dirt is excessive, use alcohol.

8. Transfer Charging Roller

- 1) Open the multifeeder tray, and detach the left cover. While taking care not to touch the roller, turn the roller by hand while lightly wiping it with lint-free paper (not leaving paper lint).



Do not touch the roller. Or, do not use water or solvent to clean the roller.

9. Static Eliminator

- 1) Open the multifeeder tray, and detach the left cover. Clean the static eliminator of the transfer charging roller and the static eliminator of the pickup guide assembly with a blower brush or lint-free paper.

The following parts must be cleaned during a visit to the user's:

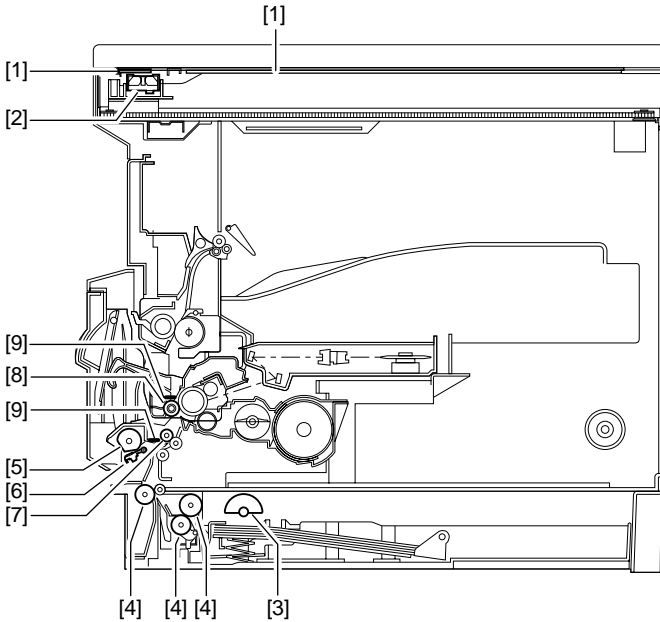

F12-401-01

- [1] Copyboard glass, Reading glass, Copyboard cover back (original retainer)
- [2] Contact sensor
- [3] Cassette pickup roller
- [4] Feeding roller, Separation roller, Vertical path roller
- [5] Manual feed pickup roller
- [6] Manual feed separation pad
- [7] Registration roller
- [8] Transfer charging roller
- [9] Pre-transfer static eliminator, Transfer static eliminator

5 Points to Note When Storing/Handling the Drum Unit

5.1 Outline

Regardless of whether its packaging seal has been removed or not, or of whether or not it has been mounted inside the machine or not, the drum unit is subject to the effects of the environment and will change over time (independently of the number of pages it has been used for).

The rate of change is determined by the site or storage conditions, and is not the same for all cases, requiring full care when storing or handling the unit.

5.2 Storage and Handling After Removing the Packaging Seal

The photosensitive drum is an organic photo conducting (OPC) drum, which will deteriorate if exposed to strong light.

5.2.1 Storage After Removing the Packaging Seal

- 1) Be sure to store it in a protective bag.
- 2) Avoid areas subject to direct rays of the sun or bright areas (i.e., near a window). Do not leave it inside a car for a long time.
- 3) Avoid areas subject to high/low temperature/humidity or areas where temperature/humidity can change rapidly.
- 4) Avoid areas subject to a corrosive gas (insecticide) or where the air is briny.
- 5) Keep the drum unit where the temperature is between 0 and 35°C.
- 6) Keep the drum unit out of reach of children.

5.2.2 Points to Note When Handling the Drum Unit

- 1) The drum unit must be transported separately from the machine. Be sure to fix the transfer charging roller in place. (See 3. of Chapter 11.) Also, be sure to keep it in a protective bag, out of light.
- 2) The photosensitive drum is vulnerable to strong light. Do not subject it to direct rays of the sun or strong light (1500 lux or higher). If exposed, it can start to produce images with white spots or black bands.
In the event images with white spots or black bands occur, leave the machine alone for a while; the faults may disappear. If the exposure is too long, however, the faults may not disappear.
- 3) Do not touch the surface of the photosensitive drum of the drum unit. Or, do not clean the photosensitive drum.

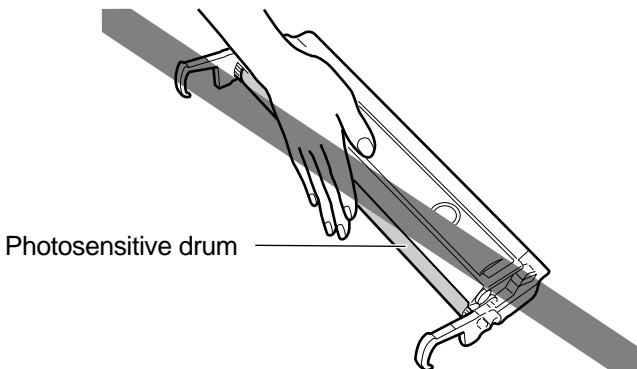

F12-502-01

- 4) Do not stand the drum unit upright or turn it over. Be sure that the side with the label faces upward.
- 5) Do not disassemble the drum unit.
- 6) Advise the user to send in used drum units to a designated address.



If exposed to light of 1500 lux in intensity (general lighting) for 5 min and then left alone in the dark for 5 min, the drum unit may recover to a degree which will not cause any practical problems. Nevertheless, avoid exposing it to direct sunshine.

The rays of the sun, in passing, is as strong as 10000 to 30000 lux in intensity.

CHAPTER 13

TROUBLESHOOTING

1 Image Adjustment Basic Procedure

1.1 Image Adjustment Basic Procedure

Go through the following to make basic adjustments:

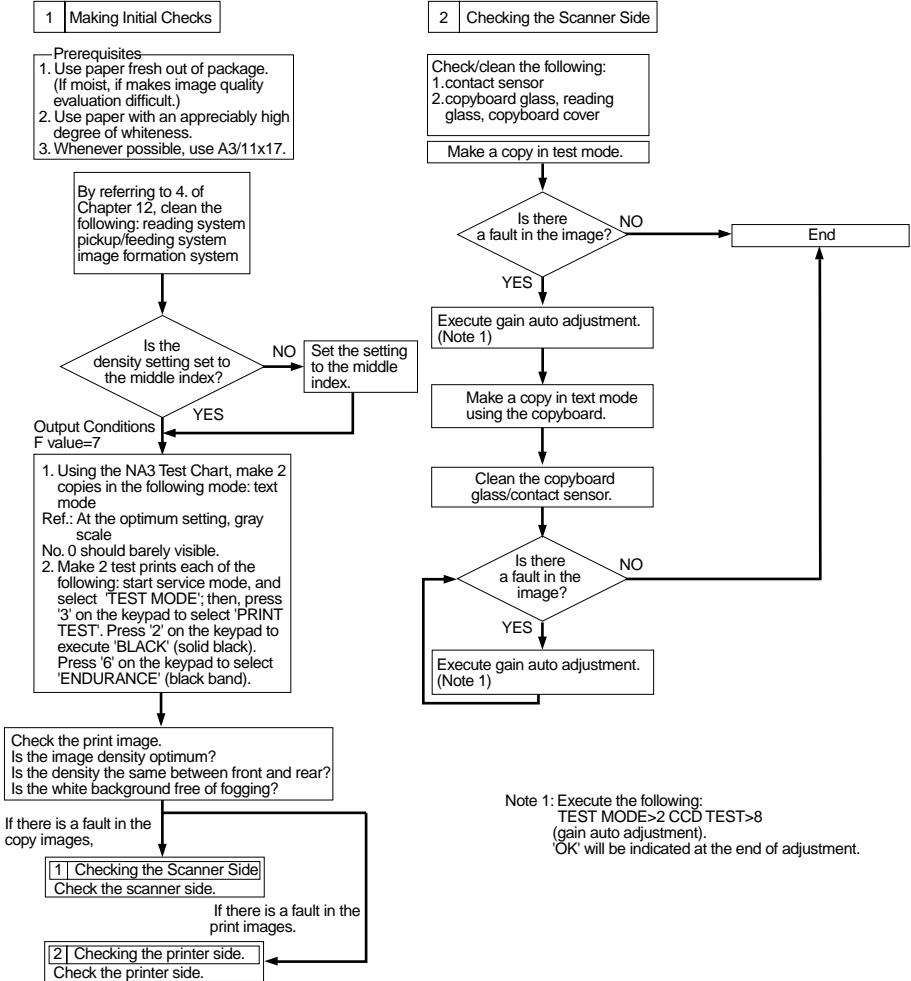

F13-101-01

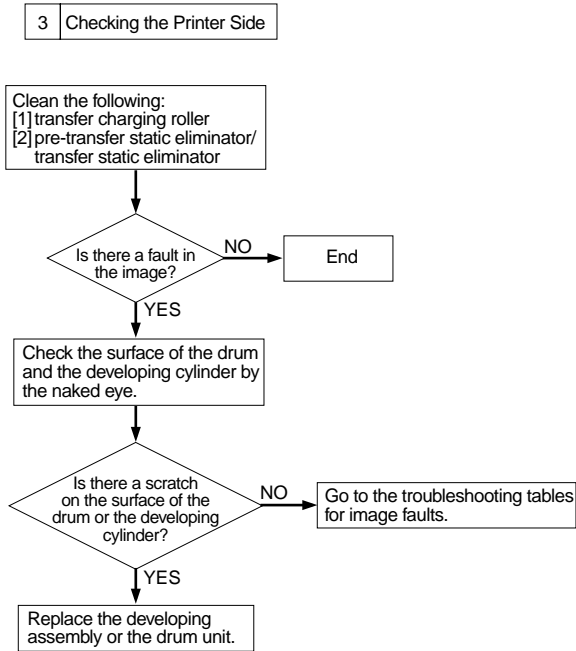

F13-101-02

2 Standards and Adjustments

2.1 Image Adjustments

2.1.1 Standards for Image Position

The image margin/non-image width on prints made in Direct must be as follows:

Image leading edge margin:

Image leading edge margin:

$A = 3.0 \pm 1.5\text{mm}$.

Image trailing edge margin:

$A = 3.0 \pm 2.0\text{mm}$.

If B4 or larger, $4.0 \pm 2.0\text{mm}$.

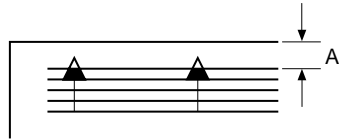

F13-201-01

Left image margin:

$B = 3.0 \pm 2.0\text{mm}$.

Right image margin:

$B = 0.5\text{mm}$ or more

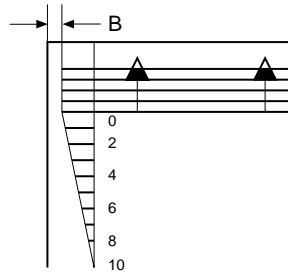

F13-201-02

Leading edge/trailing edge non-image width:

$C = 3.0 \pm 2.0\text{mm}$.

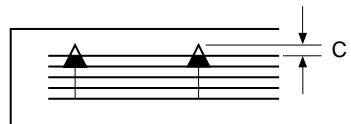

F13-201-03

2.1.2 Adjusting the Image Position

Make 10 prints each from the following sources of paper, and check to see that the image margin and non-image width are as indicated:

- cassettes
- manual feed tray

If not, go through the following to adjust the image position:

(The machine is not equipped with separate adjustment mechanisms for its cassette pickup assembly and manual feed tray pickup assembly; be sure to make the following adjustments so that they both will be as indicated.)

1) Adjusting the Leading Edge Margin for the Printer Assembly (if equipped with printer functions)

This is intended for printing that does not involve reading of an original, while 2 and 3 that follow involve reading an original.

2) Adjusting the Image Position for Copying

1. image leading edge margin adjustment (read start position in main scanning direction)
2. left/right image margin adjustment (read start position in sub scanning direction)
3. leading edge non-image width (read ratio in sub scanning direction)

2.1.3 Adjusting the Leading Edge Margin for the Printer Unit (if equipped printer functions)

- 1) Open the front cover, and detach the right cover.
- 2) Insert the door switch actuator [1] as shown.
- 3) Insert a precision screwdriver through the left opening of the inside cover, and press the test print switch (SW101) on the DC controller PCB to execute test printing.

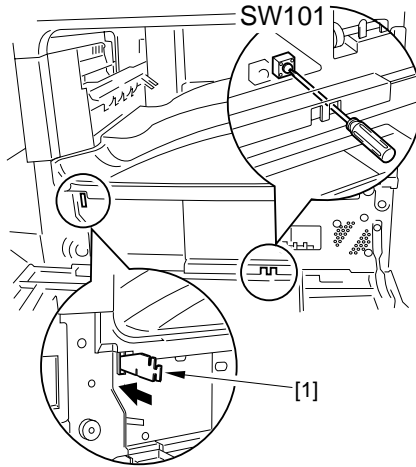

F13-201-04

- 4) Check to make sure that the leading edge of the generated image is 2.0 ± 0.5 mm.
If not, insert a precision screwdriver, and turn the volume (VR101) so that it is as indicated.
If it is less than indicated, turn the volume counterclockwise.
If it is more than indicated, turn the volume clockwise.

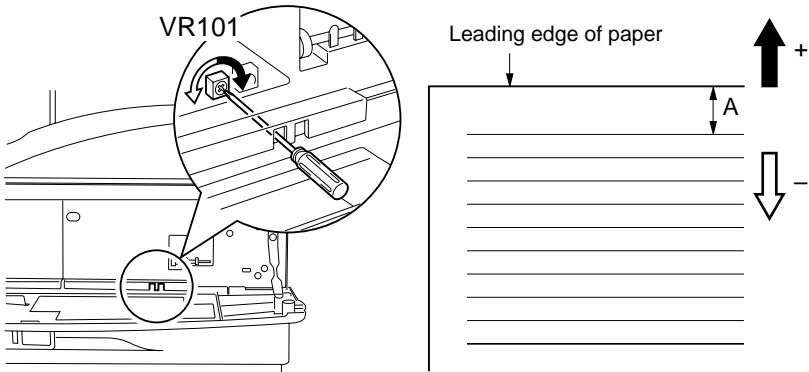

F13-201-05

2.1.4 Adjusting the Image Position for Copying

- 1) Adjust the image leading edge margin by making the following selections in service mode: #6 SCANNER>7. CCD>parameter 023.
 A higher setting will decrease the margin A.
 A lower setting will increase the margin A.
 Adjustment value of 1 = 0.1 mm (range of adjustment: 0 to 9999; default: 145)

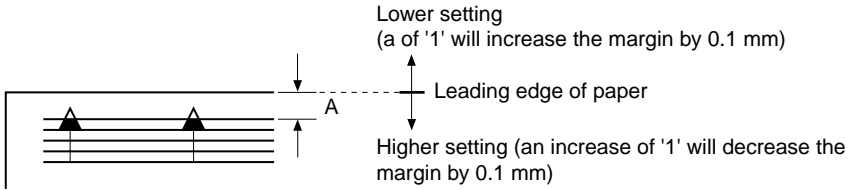

F13-201-06

- 2) Adjust the left/right image margin by making the following selections in service mode: #6 SCANNER>7. CCD>parameter 021.
 A higher setting will decrease the margin A.
 A lower setting will increase the margin A.
 Adjustment value 1 = 0.04 mm (range of adjustment: 0 to 9999; default: 128)

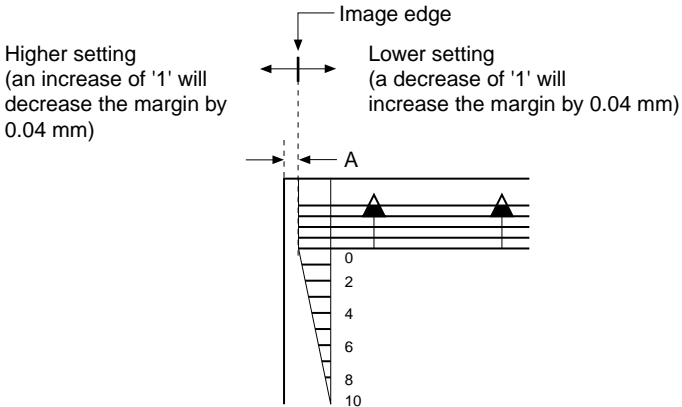

F13-201-07

- 3) Adjust the leading edge non-image width by making the following selections in service mode: #6 SCANNER>7. CCD>parameter 031.
Adjustment unit 1 = 0.1% (in positive direction; range of adjustment: 0 to 9999; default: 16)

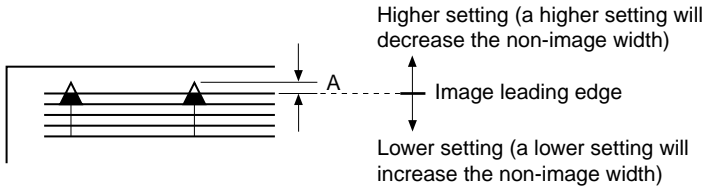

F13-201-08

2.2 Fixing System

2.2.1 Checking the Fixing Roller Pressure (nip)

The machine is not designed to allow adjustment of the nip, but an inappropriate nip can cause fixing faults; be sure to check the nip of the fixing assembly as follows:

- 1) Make a solid black copy on A3 or 11x17 paper.
- 2) Put the output in the multimeter tray with the black side facing up.
- 3) Press the Start key, and turn off the power switch as soon as the leading edge of paper reaches the delivery tray. About 10 sec thereafter, remove the paper from the machine.
- 4) Measure the width of the area indicated (where toner is glossy), and check to make sure that it is as indicated:
 - middle at a : 2.9 to 4.6 mm
 - left/right at b and c : 3.5 mm or more
 - left/right difference ($|b - c|$) : 0.5 mm or less
 - middle edge difference ($b - a, c - a$) : 0.5 mm or more

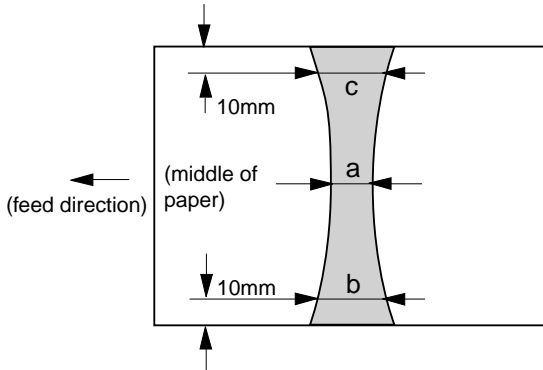

F13-202-01

2.3 Electrical Parts

2.3.1 When Replacing the Major Parts

Major part	Work
Contact sensor	gain adjustment
Image processor PCB	user data, service data settings
DC controller PCB	leading edge margin adjustment
Analog processor PCB	gain auto adjustment

2.3.2 Gain Auto Adjustment

- 1) Execute gain auto adjustment by making the following selections in service mode:
TEST MODE> 2 CCD TEST> 8.

At the end, 'OK' will be indicated. If 'NG' is indicated, check the following, and try once again:

- Is the copyboard cover (ADF) closed properly?
- Is the copyboard glass closed properly? (position of white plate)
- Is the white plate free of dirt?
- Is the lens area of the contact sensor free of dirt?

2.3.3 When Replacing the Contact Sensor

After replacing the PCB, go through the following:

- 1) Execute gain auto adjustment by making the following selections in service mode:
TEST MODE>2 CCD TEST>8.

2.3.4 When Replacing the Image Processor PCB

a. Before Starting the Work

- 1) Generate a counter report by making the following selections in service mode: #10 REPORT>COUNTER REPORT.
The counter report provides a user data list, changes made to the default settings of the system data list, and system dump list (not used).
- 2) Turn off the power switch, and disconnect the jumper plug (JP201) from the existing PCB.
- 3) If an expansion memory has been mounted, remove the memory from the image processor PCB.
- 4) Remove the ROM DIMM.
- 5) Remove the screw, and detach the counter PCB [1].



When the jumper plug (JP201) is removed, all data stored in the control memory will be lost. Be sure to check that the control data has been printed before removing the plug.

The data in the control memory includes the following:

user data : data set by the user by pressing the Additional function key in the control panel.

service mode data : service mode settings data

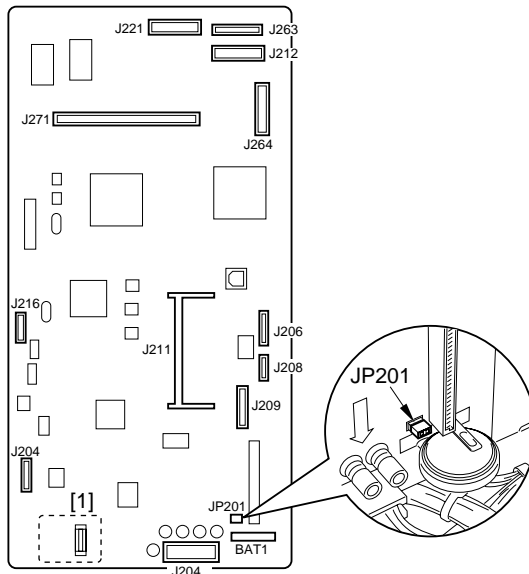

F13-203-01

b. After Replacement

- 1) Mount the counter PCB with a screw.
- 2) Mount the ROM DIMM.
- 3) Mount the expansion memory.
- 4) Connect the jumper plug (JP201) disconnected from the PCB before replacement.
- 5) Turn on the power switch; when 'DATA ERROR' is indicated, press the OK key in the control panel.
- 6) When 'SYSTEM ERROR E000' is indicated, turn off and then on the machine's power switch.
- 7) If you have replaced the image processor PCB of a machine equipped with an original sensor, make the following selections in service mode, and press the OK key to turn on the original detection function: #6 SCANNER>10. MODEL>'TYPE B'.
If the machine is not equipped with an original detection function, select 'TYPE A', and press the OK key to turn off the original detection function.
- 8) Select the following in service mode, and press the OK key: #12 CLEAR>COUNTER.
- 9) Enter the user data and service mode data.

2.3.5 When Replacing the DC Controller PCB

- 1) After replacing the PCB, adjust the leading edge margin for the printer unit. (See 2.1.3 in Chapter 13.)

2.3.6 When Replacing the Analog Processor PCB

- 1) After replacing the PCB, execute gain auto adjustment by making the following selections in service mode: TEST MODE>2 CCD TEST>8.

2.4 Checking the Sensors

2.4.1 Checking the Sensors

To find out whether a photointerrupter is good or faulty, use 'SENSOR' under 'TEST MODE' in service mode as follows:

- 1) Press the additional function key and the ID (#) key in sequence to start service mode.
- 2) Using the cursor key, select 'TEST MODE'.
- 3) Press '6' on the keypad to select '6: FACULTY TEST'.
- 4) Press '3' on the keypad to start sensor check mode, indicated by the following screen:



F13-204-01

- 5) While the above screen is indicated, press '1', '2', '3', '4', and '5' on the keypad so that the Status screen of each respective sensor will appear; for instance, when '1' is pressed on the keypad,

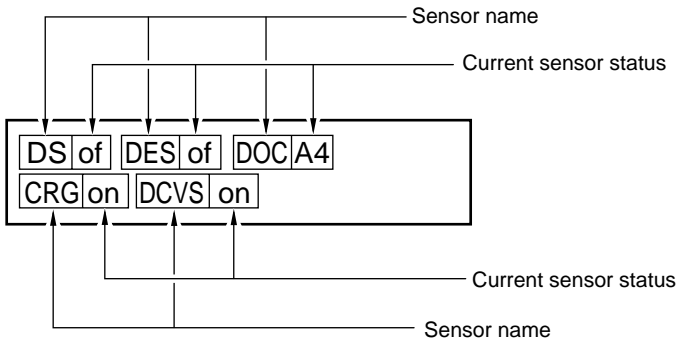

F13-204-02

- 6) Move the flag of the sensor to see that the indication alternates between 'of' and 'on', i.e., OFF and ON.
 The following shows what will take place when '1' through '4' are pressed on the keypad, indicating the sensor name and the sensor status while machine is in standby:

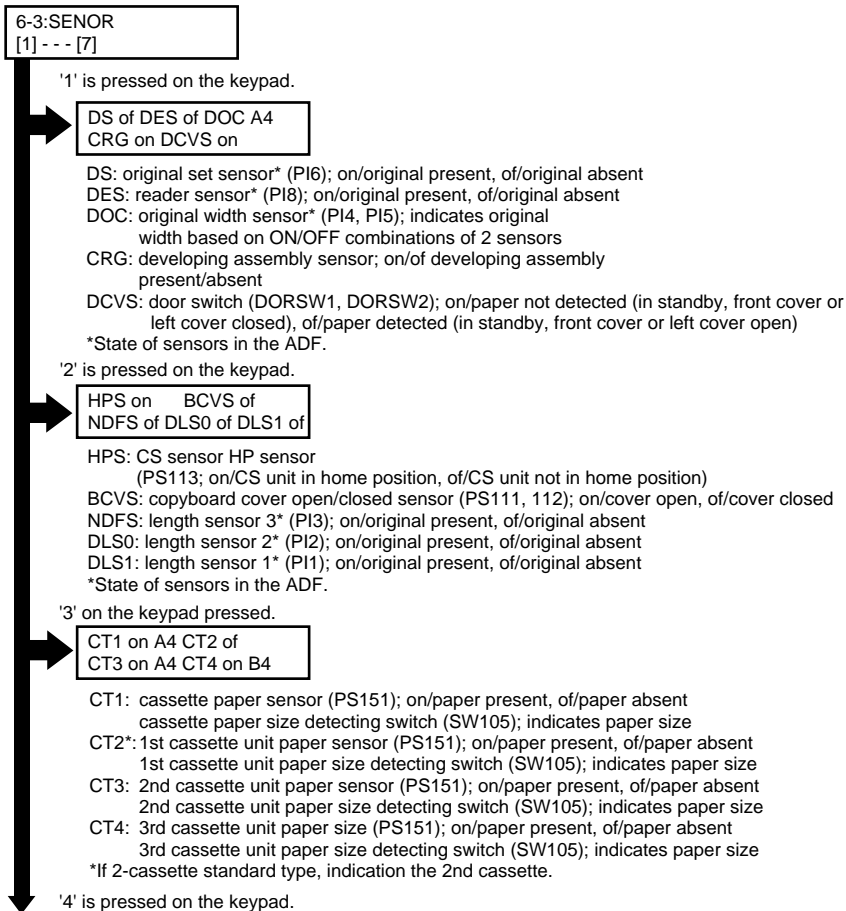

F13-204-03

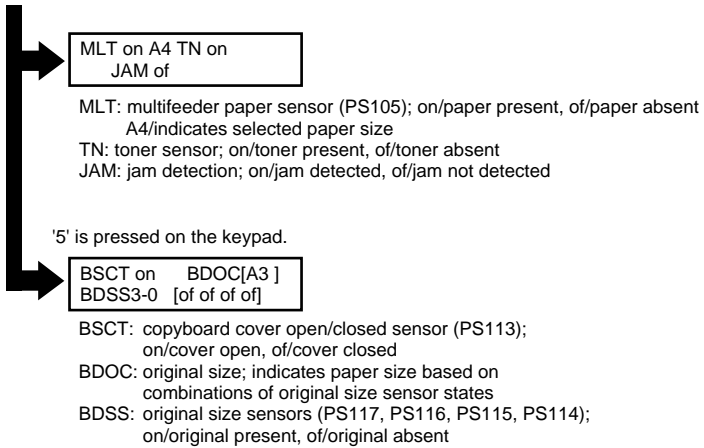

F13-204-04

3 Troubleshooting Image/Operation Faults

3.1 Making Initial Checks on Image Faults

3.1.1 Site of Installation

- 1) The voltage of the power source must be as rated ($\pm 10\%$). Be sure that the power plug remains connected day and night.
- 2) The machine must not be subjected to high temperature/humidity (near a water faucet, water boiler, humidifier). The machine must not be installed in a cold or dusty area or near a source of fire.
- 3) The machine must not be subjected to ammonium gas.
- 4) The machine must not be subjected to the direct rays of the sun. As necessary, curtains must be provided.
- 5) The machine must be installed in a well ventilated area.
- 6) The machine must be kept level.
- 7) The machine must be supplied with power night and day.

Check the sight against the above requirements.

3.1.2 Checking the Originals

Find out if the fault is caused by the original used or by the machine:

- 1) The copy density is optimum if set to 5 ± 1 (density setting).
- 2) An original with a reddish background can cause poor contrast (as in sales slips).
- 3) The density of the original can significantly affect the output.



-
- A diazo copy used as an original or an original with transparency can produce copies that can be mistaken as being “foggy.”
 - An original prepared in light pencil or with greenish characters can produce copies that can be mistaken for being “too light.”
-

3.1.3 Copyboard Cover and Copyboard Glass (standard white plate)

Check the copyboard cover and copyboard glass (standard white plate) for dirt and a scratch. If soiled, clean it with a solution of mild detergent or alcohol; if scratched, replace them.

3.1.4 Checking the Transfer Charging Roller/Static Eliminator

- 1) Check the transfer roller and the transfer/pre-transfer static eliminator for dirt and a fault (damage).
- 2) Check to make sure that the transfer roller and the transfer/pre-transfer static eliminator are mounted correctly.

3.1.5 Checking the Drum Unit

- 1) Check to be sure that the surface of the photosensitive drum is free of a scratch. Otherwise, replace the drum unit.

3.1.6 Checking the Paper

- 1) Check to see if paper of a recommended type is used. Advise the user that the use of paper not of a recommended type may not bring the best results.
- 2) Check to find out if the paper is moist. Try paper fresh out of package. Advise the user on the correct method of storing paper; moist paper will adversely affect transfer, causing poor images, separation faults, jams, or wrinkling.

3.1.7 Image Adjustment Basic Procedure

If the image is uneven in density (different between front and rear), is too light, or is foggy, go through the Image Adjustment Basic Procedure before referring to the tables that follow.

3.1.8 Others

In winter, bringing a machine from a cold to warm place can cause condensation inside the machine, leading to various problems.



-
- 1) Condensation in the CS unit will generate darker images.
 - 2) Condensation in the charging system will cause electrical leakage.
 - 3) Condensation on the pickup/feed guide can cause paper feeding faults.
If condensation has developed, dry wipe the part, or leave the machine alone and powered for 60 min.
-

Blank Page

Blank Page

2. Samples of Image Faults

Note: The samples are made artificially to provide an idea of faulty copies, and may not represent actual faults. (The NA-3 Test Sheet was copied in DIRECT mode on A4 paper, and reduced for printing.)

1. The copy is too light (halftone only).

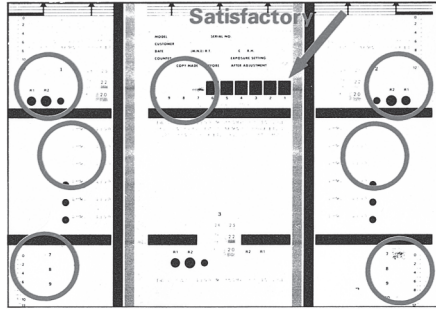

2. The copy is too light (both halftone and solid black). 3. The copy is too light (entire copy, appreciably).

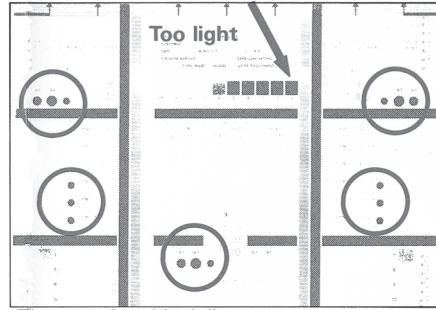

4. The copy has uneven density (darker along front).

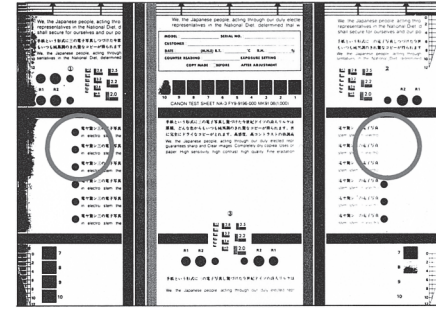

5. The copy has uneven density (lighter along front).

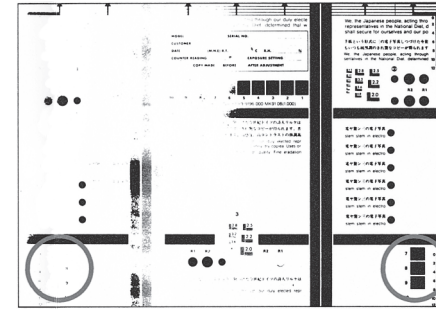

6. The copy is foggy (entire copy).

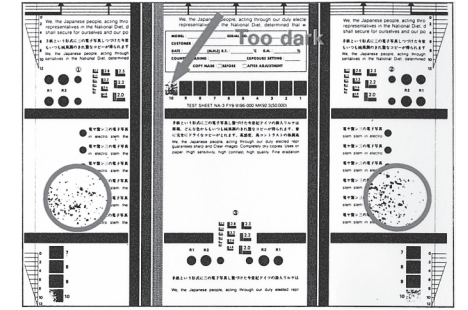

7. The copy is foggy (feeding direction).

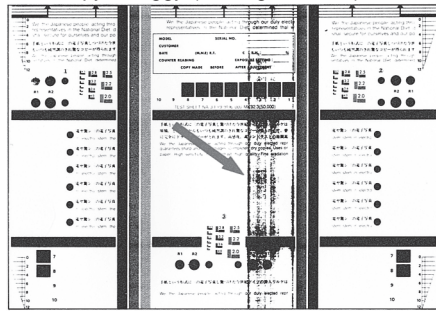

8. The copy has black lines (feeding direction, fuzzy, thick).

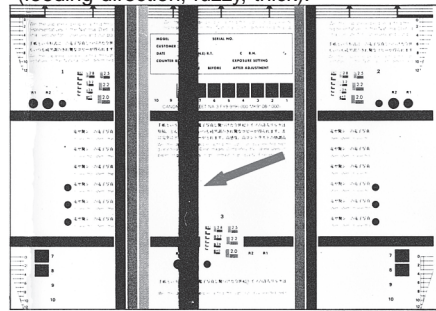

9. The copy has black lines (feeding direction, fine).

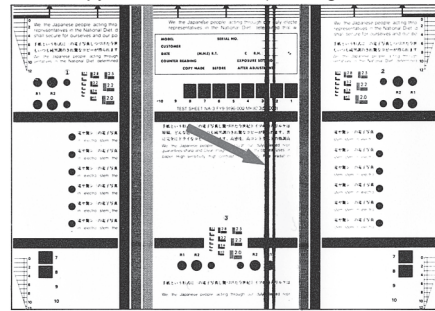

10. The copy has white strips (feeding direction).†

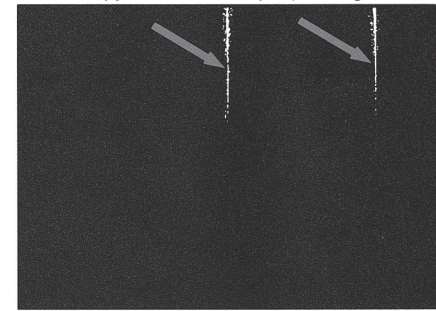

11. The copy has white lines (feeding direction).*

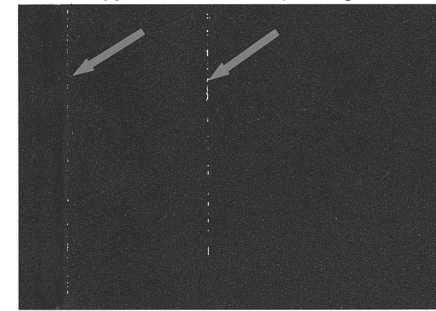

12. The copy has white strips (cross-feeding direction).

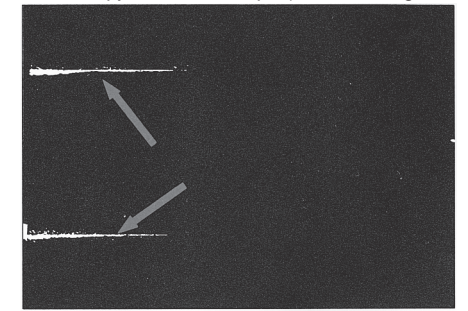

13. The back of the copy is soiled.

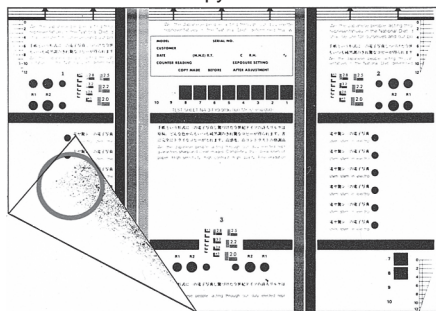

14. The copy has poor fixing.

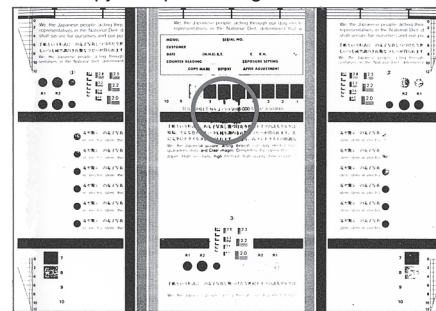

15. The copy has displaced registration (leading edge, extremely excessive margin).

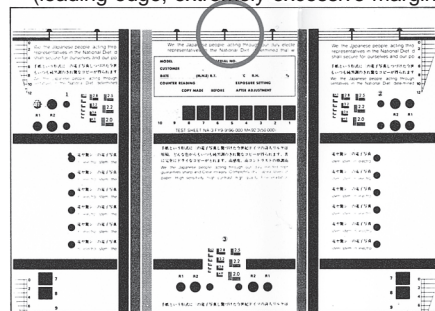

16. The copy has displaced registration (leading edge, excessive margin).

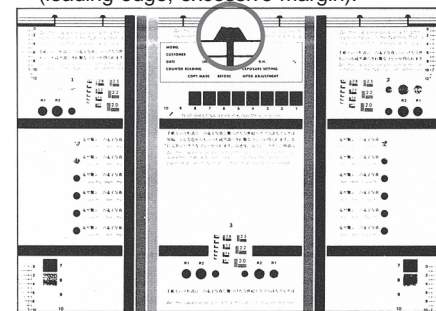

17. The copy has displaced registration (leading edge, no margin).

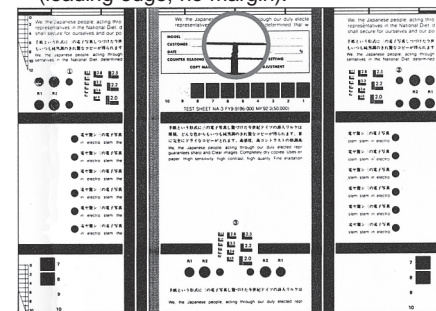

18. The copy has blurred images.

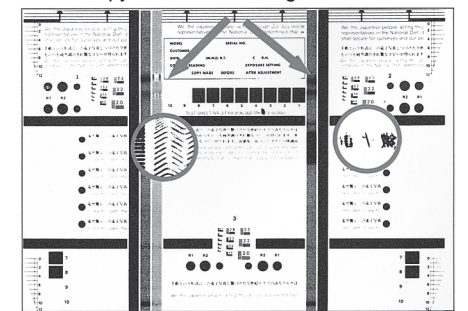

19. The copy is foggy (cross-feeding direction).

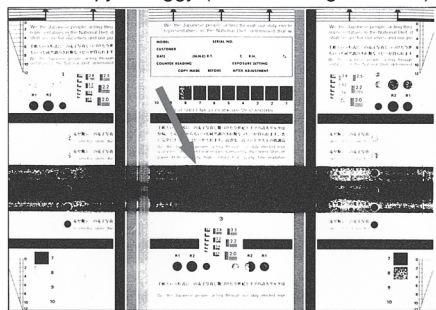

20. The copy has poor sharpness.

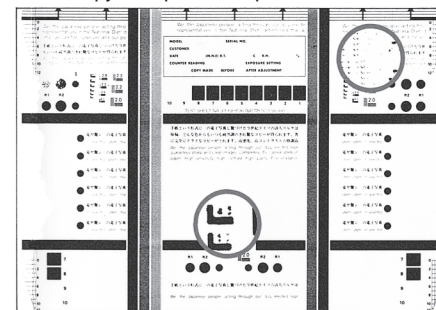

21. The copy is blank.

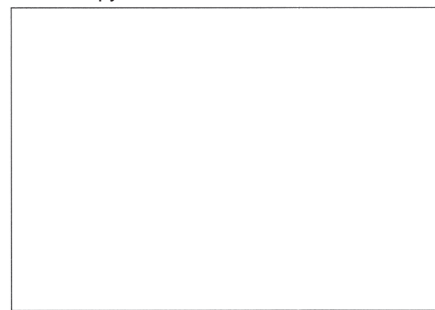

22. The copy is solid black.



* Copies made with the copyboard lifted; faults may also appear on normally made copies.

† Strips may vary in width.

3.3 Troubleshooting Image Faults

3.3.1 The copy is too light. (halftone only)

3.3.2 The copy is too light. (both halftone and solid black)

3.3.3 The copy is too light. (entire copy, appreciably)

Image density	<p>1) Is the image density setting appropriate? NO: Correct the image density setting.</p>
Paper	<p>2) Try paper fresh out of package. Is the fault corrected? YES: 1. The paper may be moist. Advise the user on the correct method of storing paper. 2. Advise the user that the use of paper not of a recommended type may not bring the best results.</p>
Machine state	<p>3) Execute 'PRINT'. Is the output image normal? (See 5.5.5 of Chapter 13.) YES: Go to step 14.</p>
Developing assembly	<p>4) Is the developing assembly firmly locked to the photosensitive drum? (Check to see that the rolls of the developing assembly are in firm contact.) NO: Mount the developing assembly correctly.</p>
Machine state	<p>5) Turn off the power switch in the middle of copying operation, and open the left cover. At this time, is the toner image on the surface of the photosensitive drum before transfer more or less normal? YES: Go to step 12.</p>
High-voltage contact (developing assembly and high-voltage leaf spring)	<p>6) Is the high-voltage leaf spring used to supply high voltage to the developing assembly soiled? (Check by removing the developing assembly.) YES: Clean the developing assembly.</p>
High-voltage contact (high-voltage leaf spring and DC controller PCB)	<p>7) Is the connector between the high-voltage leaf spring and the DC controller PCB normal? NO: Correct the connection. If the fault cannot be corrected, replace the faulty part.</p>

Connector	<p>8) Is the connection between the connector (J102) on the DC controller PCB and the connectors (J907, J908) of the laser scanner unit normal? NO: Correct the connection.</p>
Drum unit	<p>9) Try replacing the drum unit. Is the fault corrected? YES: End.</p>
Developing assembly	<p>10) Try replacing the developing assembly. Is the fault corrected? YES: End.</p>
Laser scanner unit, DC controller PCB	<p>11) Try replacing the laser scanner unit. Is the fault corrected? YES: End. NO: Replace the DC controller PCB.</p>
High-voltage contact (transfer charging roller and high-voltage left spring)	<p>12) Is there high-voltage spring used to supply high voltage to the transfer charging roller soiled? YES: Clean the leaf spring.</p>
High-voltage contact (high-voltage leaf spring, DC controller PCB), Transfer charging roller	<p>13) Is the connection between the high-voltage leaf spring and the DC controller PCB normal? YES: Replace the toner charging roller. NO: Correct the connection. If the fault cannot be corrected, replace the faulty part.</p>
Contact sensor (rod lens array)	<p>14) Clean the rod lens array of the contact sensor. Is the problem corrected? YES: End.</p>
Gain auto adjustment	<p>15) Execute gain auto adjustment. Is the fault corrected? (See 2.3.2 of Chapter 13.) YES: End.</p>
CS unit	<p>16) Are the CS unit and the spacers mounted correctly? Also, are the spacers free of wear? NO: Correct the mounting. If the fault cannot be corrected, replace the faulty part.</p>

Connector	<p>17) Is the connection of the connectors (J1, J3) on the analog processor PCB and the connector (J221) on the image processor PCB, and the connector (J30) on the contact sensor normal?</p> <p>NO: Correct the connection. If the flexible cable has a scratch, replace it.</p>
Contact sensor	<p>18) Try replacing the contact sensor. Is the fault corrected?</p> <p>YES: End.</p>
Analog processor PCB, Image processor PCB	<p>19) Try replacing the analog processor PCB. Is the problem corrected?</p> <p>YES: End.</p> <p>NO: Replace the image processor PCB.</p>

- 3.3.4 The copy has uneven density. (darker along front)
- 3.3.5 The copy has uneven density. (lighter along front)

Image density	<p>1) Is the image density setting appropriate? NO: Correct the image density setting.</p>
Machine state	<p>2) Execute 'PRINT'. Is the output image normal? (See 5.5.5 of Chapter 13.) YES: Go to step 7.</p>
Developing assembly	<p>3) Is the developing assembly locked to the photosensitive drum firmly? (Check to see if the rolls of the developing assembly are firmly in contact.) NO: Mount the developing assembly correctly.</p>
Transfer charging roller	<p>4) Clean the transfer charging roller. Is the fault corrected? YES: End.</p>
Transfer charging roller	<p>5) Try replacing the transfer charging roller. Is the fault corrected? YES: End.</p>
Drum unit	<p>6) Try replacing the drum unit. Is the fault corrected? YES: End.</p>
Contact sensor (rod lens array)	<p>7) Clean the rod lens array of the contact sensor. Is the fault corrected? YES: End.</p>
Gain auto adjustment	<p>8) Execute gain auto adjustment. Is the fault corrected? (See 2.3.2 of Chapter 13.) YES: End.</p>
CS unit	<p>9) Are the CS unit and the spacers mounted correctly? Also, are the spacers free of wear? YES: Replace the contact sensor. NO: Correct the fault. If the correction is not possible, replace the faulty part.</p>

3.3.6 The copy is foggy. (entire copy)

Image density	<p>1) Is the image density setting appropriate? NO: Correct the image density setting.</p>
Machine state	<p>2) Execute 'PRINT'. Is the output image normal? (See 5.5.5 of Chapter 13.) YES: Go to step 5.</p>
Developing assembly	<p>3) Is the developing assembly locked to the photosensitive drum firmly? (Check to see if the rolls of the developing assembly are firmly in contact.) NO: Mount the developing assembly correctly.</p>
Drum unit, Developing assembly	<p>4) Is the drum grounding shaft of the drum unit free of dirt and deformation? YES: Correct the fault. If the fault cannot be corrected, replace the drum unit. NO: Replace the developing assembly.</p>
Contact sensor (rod lens array)	<p>5) Clean the rod lens array of the contact sensor. Is the fault corrected? YES: End.</p>
Gain auto adjustment	<p>6) Execute gain auto adjustment. Is the fault corrected? (See 2.3.2 of Chapter 13.) YES: End.</p>
CS unit	<p>7) Are the CS unit and the spacers mounted correctly? Also, are the spacers free of wear? YES: Replace the contact sensor. NO: Correct the fault. If the correction is not possible, replace the faulty part.</p>

3.3.7 The copy is foggy. (feeding direction).

3.3.8 The copy has black lines. (feeding direction, fuzzy, thick)

3.3.9 The copy has black lines. (feeding direction, fine)

Machine state	<p>1) Execute 'PRINT'. Is the output image normal? (See 5.5.5 of Chapter 13.) YES: Go to step 5.</p>
Developing assembly	<p>2) Is the coating of toner on the developing cylinder even? NO: Rotate the developing assembly cylinder to see if the coating becomes even. If not, replace the developing assembly.</p>
Drum unit	<p>3) Is there a scratch or black line in the peripheral direction of the surface of the photosensitive drum? YES: Replace the drum unit.</p>
Fixing assembly	<p>4) Execute fixing roller cleaning in user mode. Is the fault corrected? YES: End. NO: Replace the fixing assembly.</p>
Contact sensor (rod lens array)	<p>5) Clean the rod lens array of the contact sensor. Is the fault corrected? YES: End.</p>
Gain auto adjustment	<p>6) Execute gain auto adjustment. Is the fault corrected? (See 2.3.2 of Chapter 13.) YES: End.</p>
CS unit	<p>7) Are the CS unit and the spacers mounted correctly? Also, are the spacers free of wear? YES: Replace the contact sensor. NO: Correct the fault. If the fault cannot be corrected, replace the faulty part.</p>

3.3.10 The copy has white strips. (feeding direction)

3.3.11 The copy has white lines. (feeding direction)

Machine state	<p>1) Execute 'PRINT'. Is the output image normal? (See 5.5.5 of Chapter 13.) YES: Go to step 6.</p>
Developing assembly	<p>2) Is the coating of toner on the developing cylinder even? NO: Rotate the developing cylinder to see if the coating becomes even. If not, replace the developing assembly.</p>
Drum unit	<p>3) Is there a scratch or black line in the peripheral direction of the surface of the photosensitive drum? YES: Replace the drum unit.</p>
Transfer charging roller, Pre-transfer static eliminator	<p>4) Is the transfer charging roller or the pre-transfer static eliminator coated with foreign matter? YES: Clean the transfer roller or the transfer static eliminator. If the fault is not corrected, replace the transfer charging roller or the transfer static eliminator.</p>
Fixing assembly	<p>5) Execute fixing roller cleaning in user mode. Is the fault corrected? YES: End. NO: Replace the fixing assembly.</p>
Gain auto adjustment	<p>6) Execute gain auto adjustment. Is the problem corrected? (See 2.3.2 of Chapter 13.) YES: End.</p>
Contact sensor, Standard white plate	<p>7) Clean the rod lens array of the contact sensor and the copyboard glass (standard white plate). Is the fault corrected? YES: End.</p>
Shading position correction	<p>8) For shading position correction in service mode, set a level between '90' and '72' for '6 SCANNER>7 CCD>parameter '19'. Is the fault corrected? YES: End. NO: Replace the copyboard glass. If the fault cannot be corrected, go to step 9).</p>
CS unit	<p>9) Are the CS unit and the spacers mounted correctly? Also, are the spacers free of water? YES: Replace the contact sensor. NO: Correct the fault. If the fault cannot be corrected, replace the faulty part.</p>

3.3.12 The output has white strips. (cross-feeding direction)

Paper	<p>1) Try paper fresh out of package. Is the problem corrected? YES: 1. The paper may be moist. Advise the user on the correct method of storing paper. 2. Advise the user that the use of paper not of a recommended type may not bring the best results.</p>
Machine state	<p>2) Execute 'PRINT'. Is the output image normal? (See 5.5.5 of Chapter 13.) YES: Go to step 5.</p>
Developing assembly	<p>3) Is there a scratch on the surface of the developing assembly? YES: Replace the developing assembly.</p>
Drum unit	<p>4) Is there a scratch in the surface of the photosensitive drum? YES: Clean the drum. If the fault is not corrected, replace the drum unit.</p>
Contact sensor	<p>5) Clean the rod lens array of the contact sensor. Is the fault corrected? YES: End.</p>
Gain auto adjustment	<p>6) Execute gain auto adjustment. Is the fault corrected? (See 2.3.2 of Chapter 13.) YES: End.</p>
CS unit	<p>7) Are the CS unit and the spacers mounted correctly? Also, are the spacers free of wear? YES: Replace the contact sensor. NO: Correct the fault. If the fault cannot be corrected, replace the faulty part.</p>

3.3.13 The back of the copy is soiled.

Paper, Selected mode

1) Is the selected fixing mode suited to the paper used?

YES: Select the appropriate mode.

Exposure system

2) Turn off the power switch immediately before the paper moves past the fixing assembly. Is the back of the paper soiled at this time?

NO: Go to step 4.

Registration roller, Transfer charging roller

3) Is the fault at specific intervals?

YES: If it is at intervals of about 50 mm, clean the registration roller.

If it is at intervals of about 55 mm, clean the transfer charging roller.

If the dirt cannot be removed, replace the roller.

NO: Clean the guide.

Fixing assembly

4) Execute fixing roller cleaning in user mode. Is the fault corrected?

YES: End.

NO: Replace the fixing assembly.

3.3.14 The copy has a poor fixing.

Paper	<p>1) Try paper fresh out of package. Is the fault corrected? YES: 1. The paper may be moist. Advise the user on the correct method of strong paper. 2. Advise the user that the use of paper not of a recommend type may not bring the best results.</p>
Paper, Selected mode	<p>2) Is the selected fixing mode suited to the paper used? YES: Select the appropriate mode.</p>
Pressure roller	<p>3) Is the roller pressure (nip) as indicated? YES: End.</p>
Fixing assembly	<p>4) Try replacing the fixing assembly. Is the fault corrected? YES: Replacing the fixing assembly. NO: Replace the DC controller PCB.</p>

3.3.15 The copy has displaced registration. (leading edge extremely excessive margin).

3.3.16 The copy has displaced registration. (leading edge, excessive margin)

3.3.17 The copy has displaced registration. (leading edge, no margin)

Original	<p>1) Is the original placed correctly? NO: Place the original correctly.</p>
ADF	<p>2) Is an ADF used? YES: Adjust the leading edge for the ADF as instructed in the ADF Service Manual.</p>
Pickup roller, Feed roller, Separation roller	<p>3) Try replacing the pickup, feeding, and separation roller of the source of paper (cassette). Is the problem corrected? YES: Replace the roller in question.</p>
Image position	<p>4) Try image position adjustment in service mode. Is the fault corrected? (See 2.1.2 of Chapter 13.) YES: End.</p>
Registration clutch, DC controller PCB	<p>5) Is the registration clutch operating normally? YES: Replace the DC controller PCB. NO: Replace the registration clutch.</p>

3.3.18 The copy has blurred images.

Machine state	<p>1) Execute 'PRINT'. Is the output image blurry? (See 5.5.5 of Chapter 13.) YES: Go to step 5.</p>
CS unit drive belt	<p>2) Is the drive belt wound around the drive pulley of the reader unit too taut or too loose? YES: Correct the drive belt. If the fault cannot be corrected, replace the drive belt.</p>
Carriage rail	<p>3) Move the carriage slowly by hand. Does it move smoothly? NO: Clean the surface of the carriage rail with alcohol; then, apply a small amount of lubricant.</p>
Rear motor, Original detection/Reader motor drive PCB, Image processor PCB	<p>4) Is the rear motor operating normally? YES: Replace the original detection/reader motor drive PCB. If the fault is not corrected, replace the image processor PCB. NO: Replace the reader motor.</p>
Feeding assembly	<p>5) Is there foreign matter or burrs on the feed guide? NO: Correct the fault. If the fault cannot be corrected, replace the faulty part.</p>
Photosensitive drum	<p>6) Does the fault occur at intervals of about 97 mm? YES: Check the ends of the drum (area in contact with developing rolls) for a scratch and foreign matter.</p>
Developing assembly, Drum unit	<p>7) Does the fault occur at intervals of about 50 mm? YES: Check the developing assembly, and mount it correctly. If the fault cannot be corrected, replace the developing assembly. NO: Replace the drum unit.</p>

3.3.19 The copy is foggy. (cross-feeding direction)

Machine state	1) Make a copy in Direct. Does the fault occur in the same location? YES: Go to step 3.
Wiring	2) Is the wiring of the CS unit, original detection/reader motor drive PCB, and image processor PCB normal? NO: Correct the wiring.
Photosensitive drum	3) Does the fault occur at intervals of about 97 mm? YES: Check the drum unit, and mount it correctly. If the fault is not corrected, replace the drum unit.
Developing assembly, Drum unit	4) Does the fault occur at intervals of about 50 mm? YES: Check the developing assembly, and mount it correctly. If the problem is not corrected, replace the developing assembly.
Reader unit, Feeding system	5) Make a reduced copy (about 50% to 60%), and compare it against a copy made in Direct. Is the location of the fault different? YES: Check the rear unit. NO: Check the feeding system.

3.3.20 The copy has poor sharpness.

Sharpness setting

1) Is the sharpness setting of user mode correct?

NO: Set sharpness to a correct setting.

Copyboard glass

2) Is the copyboard glass soiled with oil? Is there foreign matter on the copyboard glass stay?

YES: Clean the copyboard glass.

Contact sensor

3) Clean the rod lens array of the contact sensor. Is the fault corrected?

YES: End.

Gain auto adjustment

4) Execute gain auto adjustment. Is the fault corrected? (See 2.3.2 of Chapter 13.)

YES: End.

CS unit

5) Are the CS unit and the spacers mounted correctly? Also, are the spacers free of wear?

NO: Correct the fault. If the fault is not corrected, replace the faulty part.

Transfer charging roller

6) Try replacing the transfer charging roller. Is the problem corrected?

YES: End.

Developing assembly, Drum unit

7) Try replacing the drum unit. Is the problem corrected?

YES: End.

NO: Replace the developing assembly.

3.3.21 The copy is blank.

Developing assembly

- 1) Is the developing assembly firmly locked against the photosensitive drum? (Check to see if the rolls of the developing assembly are in firm contact.)**

NO: Mount the developing assembly correctly.

Laser shutter arm, Laser shutter

- 2) Are the laser shutter arm and the laser shutter operating normally? Are they damaged?**

YES: Replace the faulty part.

High-voltage leaf spring

- 3) Is the connection between the contact of the high-voltage left spring and the developing assembly normal?**

NO: Clean the contacts. If the fault is not corrected or deformation/damage is found, replace the faulty part. In the cassette of the leaf spring of the developing assembly, replace the developing assembly.

Drum unit

- 4) Try replacing the drum unit. Is the fault corrected?**

YES: End.

Developing assembly

- 5) Try replacing the developing assembly. Is the fault corrected?**

YES: End.

High-voltage leaf spring, DC controller PCB

- 6) Is the connection between the contact for the developing bias on the DC controller PCB and the contact of the leaf spring for the developing bias normal?**

YES: Replace the DC controller PCB.

NO: Clean the contact. If the problem is not corrected, or deformation/damage is found, replace the faulty part.

3.3.22 The copy is solid black.

Machine state	<p>1) Execute ‘PRINT’. is the output image normal? (See 5.5.5 of Chapter 13.) NO: Go to sep 6.</p>
Contact sensor	<p>2) Is the contact sensor ON during copying? NO: See “The contact sensor fails to go ON.”</p>
Connector	<p>3) Is the connection of the connectors (J1, J3) on the analog processor PCB, the connector (J221) on the image processor PCB, and the connector (J30) on the contact sensor normal? NO: Correct the connection. If the flexible cable has a scratch, replace it.</p>
Contact sensor	<p>4) Try replacing the contact sensor. Is the problem corrected? YES: End.</p>
Analog processor PCB, Image processor PCB	<p>5) Try replacing the analog processor PCB. Is the problem corrected? YES: End. NO: Replace the image processor PCB.</p>
High-voltage leaf spring	<p>6) Is the connection between the contact of the leaf spring for the primary charging bias and the contact of the developing assembly normal? NO: Clean the contacts. If the problem is not corrected, or if the damage/deformation is found, replace the faulty part.</p>
Drum unit	<p>7) Try replacing the drum unit. Is the problem corrected? YES: End.</p>
Developing assembly	<p>8) Try replacing the developing assembly. Is the problem corrected? YES: End.</p>
High-voltage leaf spring	<p>9) Is the connection between the contact for the primary charging bias on the DC controller PCB and the contact of the developing assembly normal? YES: Replace the DC controller PCB. NO: Clean the contacts. If the fault is not corrected, or deformation/damage is found, replace the faulty part.</p>

3.4 Troubleshooting Malfunctions

3.4.1 AC power is absent.

Initial checks	<ol style="list-style-type: none"> 1) Is the power plug connected to the power outlet? 2) Is the rated AC voltage present at the power outlet? 3) Does the power switch operate normally?
Power supply PCB	<ol style="list-style-type: none"> 4) IS the fuse (F1) on the power supply blown? YES: Remove the cause, and replace the power supply PCB.
Wiring, Connector	<ol style="list-style-type: none"> 5) Is the wiring (continuity) and connection (connector contact) of the wiring of the connectors (CN1, CN2, CN3) on the power supply PCB normal? NO: Correct the connection. If the flexible cable or the harness has a scratch, replace it. YES: Replace the power supply PCB.

3.4.2 DC power is absent.

AC power supply

1) Is AC voltage present?

NO: See 3.4.1 "AC power is absent."

Power supply PCB

2) Is the output voltage of each power supply PCB correct?

<u>Connector</u>		<u>Output voltage</u>
CN-11, 13	CN2-8, 9	3SV1
CN-15, 17, 19, 20		3SV2
CN2-12, 13		5VS
CN1-1		12VS
CN1-7		3VR
CN1-6		5VR
CN3-1, 2		24VR1
CN2-18 to CN2-27		24VR2

YES: Check the wiring from each power supply PCB to each load.

NO: If a fault is found, replace the power supply PCB.

3.4.3 Pickup operation fails. (cassette)

Main motor (M101)	1) Is 'E010' (fault in main motor) indicated? YES: See the descriptions for 'E010' in 6.2.1.
Machine state	2) Is the pickup roller rotating? NO: Go to step 6.
Paper	3) Is the cassette fitted correctly? NO: Replace the cassette.
Pickup roller	4) Is there wear or cracking in the surface of the pickup roller? YES: Replace the pickup roller.
Pickup drive assembly gear	5) Is there damage/foreign matter on the gear of the pickup roller drive assembly? YES: If damage is found, replace the gear. If foreign matter is found, remove it.
Cassette pickup solenoid (SL: 151)	6) Are the connection and the wiring between the connector (J906) of the cassette pickup sensor and the connector (J106) on the DC controller PCB normal? NO: Correct the connection or the wiring.
Cassette pickup solenoid, DC controller PCB	7) Does the cassette pickup solenoid operating normally? NO: Replace the cassette pickup solenoid.
Cassette controller PCB (if 2-cassette type)	8) Try replacing the cassette controller PCB. Is the fault corrected? YES: End.
DC controller PCB, Image processor PCB	9) Try replacing the DC controller PCB. Is the fault corrected? YES: Replace the DC controller PCB. NO: Replace the image processor PCB.

3.4.4 Pickup operation fails. (multifeeder tray)

Main motor (M101)	<p>1) Is 'E010' (fault in main motor) indicated? YES: See the descriptions for 'E010' in 6.2.1.</p>
User mode setting	<p>2) Is multifeeder tray selected in the control panel? NO: Select the multifeeder tray.</p>
Paper	<p>3) Is paper placed correctly in the multifeeder tray? NO: Place the paper correctly.</p>
Holding plate lift mechanism	<p>4) Does the holding plate move up in keeping with pickup timing? NO: Check the spring used to push up the holding plate.</p>
Pickup roller	<p>5) Is there wear or cracking in the surface of the manual feed pickup roller? YES: Replace the pickup roller.</p>
Pickup drive assembly gear	<p>6) Is there damage/foreign matter on the gear of the pickup roller drive assembly? YES: If damage is found, replace the gear. If foreign matter is found, remove it.</p>
Multifeeder pickup solenoid (SL101)	<p>7) Is the connection between the connector (J904) of the multifeeder pickup solenoid and the connector (J106) on the DC controller PCB normal? NO: Correct the connection.</p>
Multifeeder pickup solenoid, DC controller PCB	<p>8) Does the multifeeder pickup solenoid operating normally? YES: Replace the DC controller PCB. NO: Replace the multifeeder solenoid.</p>

3.4.5 Pickup operation fails. (cassette unit)

Main motor (M101)	<p>1) Is 'E010' (main motor fault) indicated? YES: See the descriptions for 'E010' in 6.2.1.</p>
Machine state	<p>2). Is the pickup roller rotating? NO: Go to step 5.</p>
Paper	<p>3) Is the cassette fitted correctly. NO: Fit the cassette correctly.</p>
Pickup roller	<p>4) Is there wear, scratches, or cracks in the surface of the pickup roller? YES: Replace the pickup roller.</p>
Pickup drive assembly gear	<p>5) Is there damage/foreign matter in the pickup roller drive assembly? YES: If damage is found, replace the damaged gear. If foreign matter is found, remove it.</p>
Cassette pickup solenoid (SL151)	<p>6) Is the connection between the connector of the cassette pickup solenoid and the connector of the cassette unit controller PCB normal? NO: Connect the connectors correctly.</p>
Cassette pickup solenoid	<p>7) Does the cassette pickup solenoid operate normally? NO: Replace the cassette pickup solenoid.</p>
Pickup motor (M104; for 3rd/4th cassette)	<p>8) Does the pickup motor operate normally? YES: Replace the pickup motor. NO: Replace the cassette pickup solenoid.</p>
Cassette unit controller PCB/DC controller PCB	<p>9) Try replacing the cassette unit controller PCB. Is the fault corrected? YES: Replace the cassette unit controller PCB. NO: Replace the DC controller PCB.</p>

3.4.6 The vertical path roller fails to rotate.

Main motor (M101)	<p>1) Is 'E010' (fault in main motor) indicated? YES: See the descriptions for 'E010' in 6.2.1.</p>
Machine state	<p>2) Is the pickup roller rotating? YES: Check the vertical path roller drive assembly for damage/foreign matter. If damage is found, replace the gear. If foreign matter is found, remove it. NO: See "Pickup operation fails" for the source of paper used.</p>

3.4.7 The registration roller fails to rotate.

Connector	<p>1) Is the connection between the connector (J905) of the registration clutch and the connector (J106) on the DC controller PCB normal? NO: Correct the connection.</p>
Registration clutch	<p>2) Try replacing the registration clutch. Is the problem corrected? YES: Replace the registration clutch. NO: Replace the DC controller PCB.</p>

3.4.8 The contact sensor fails to go ON.

Contact sensor	<p>1) Turn off the power switch, and disconnect the power plug from the power outlet. Is the contact sensor mounted corrected? NO: Mount it correctly.</p>
Analog processor PCB	<p>2) Is the connection between the connector (J10) on the analog processor PCB and the connector (J30) of the contact sensor normal? NO: Correct the connection.</p>
Image processor PCB	<p>3) Is the connection between the connector (J3) on the analog processor PCB and the connector (J221) on the image processor PCB normal? NO: Correct the connection.</p>
Contact sensor, Analog processor PCB	<p>4) Try replacing the contact sensor. Is the problem corrected? YES: End. NO: Replace the analog processor PCB.</p>

3.4.9 The speaker fails to operate.

Volume setting	<p>1) Is the speaker volume setting in user mode correct? YES: End.</p>
Image processor PCB	<p>2) Is the connection of the connector (J244) of the image processor PCB correct? NO: Correct the correction.</p>
Speaker, Image processor PCB	<p>3) Try replacing the speaker. Is the problem corrected? YES: End. NO: Replace the image processor PCB.</p>

3.4.10 The 'Add Toner' message fails to go OFF.

Developing assembly

- 1) **Is the leaf spring of the contacts between the developing assembly and the machine soiled with toner or the like?**
YES: Clean the contacts. If the leaf spring has a scratch or deformation, replace it.

DC controller PCB

- 2) **Is the leaf spring of the high-voltage contact of the DC controller PCB deformed?**
NO: Correct the fault. If the leaf spring has a scratch or deformation, replace it.

Developing assembly

- 3) **Try replacing the developing assembly. Is the fault corrected?**
YES: Replace it.
NO: Replace the DC controller PCB.

3.4.11 The 'Add Paper' message fails to go OFF. (machine and cassette unit)

Cassette	<p>1) Is the cassette fitted correctly? NO: Fit the cassette correctly.</p>
Paper size lever	<p>2) Is the paper size lever of the cassette displaced or damaged? YES: Correct the fault. If damage is found, replace it.</p>
Cassette holding plate lift mechanism	<p>3) Is the holding plate in up position when the cassette is fitted? NO: Turn over the cassette, and check the holding plate retaining lever and the spring for damage.</p>
Cassette paper sensor (PS151)	<p>4) Is the flag of the cassette paper sensor displaced or damaged? YES: Replace the flag.</p>
Connector	<p>5) Check the following for connection:</p> <ul style="list-style-type: none"> • If the cassette is of the machine, J101 of the DC controller PCB • If the cassette is of the cassette unit, Is the connector of the cassette unit controller PCB in firm contact? <p>NO: Correct the connection.</p>
Cassette paper sensor (PS151)	<p>6) Try replacing the paper sensor. Is the fault correct? YES: End.</p>
Paper detecting switch (SW105), DC controller PCB, Cassette unit controller PCB	<p>7) Try replacing the paper detecting switch. Is the problem corrected? YES: End. NO: If the cassette is of the machine, replace the DC controller PCB; if the cassette is of the cassette unit, replace the cassette unit controller PCB.</p>

3.4.12 The 'Add Paper' message fails to go OFF. (multifeeder tray)

Multifeeder paper sensor (PS105)	<p>1) Is the flag of the multifeeder paper sensor operating normally? NO: Correct the fault. If damage is found, replace it.</p>
Connector	<p>2) Is the connection of the connector J108 on the DC controller PCB normal? NO: Correct the connection.</p>
DC controller PCB	<p>3) Try replacing the multifeeder paper sensor. Is the problem corrected? YES: Replace the multifeeder paper sensor. NO: Replace the DC controller PCB.</p>

3.4.13 The 'Jam' message fails to go OFF.

Sensor flag	<p>1) Is the flag of the following sensors used to detect a jam damaged or displaced?</p> <ul style="list-style-type: none"> • retry sensor (PS152) • registration paper sensor (PS101) • delivery sensor (PS103) • No. 2 delivery sensor (PS201; if equipped with inter 2-way tray) <p>YES: Correct the fault. If damage is found, replace it.</p>
Sensor, DC controller PCB, Cassette unit controller PCB	<p>2) Check each sensor in test mode ('sensor test'). Is each of them normal? NO: Replace any fault sensor. YES: Replace the DC controller PCB or the cassette unit controller PCB.</p>

3.4.14 The 'Waste Toner Full' message does not go OFF.

Drum unit	1) Is the drum unit full of waste toner? YES: Replace the drum unit.
Connector connection, Wiring	2) Are the connection and wiring of the connector J113 on the DC controller PCB and the connector J999 on the waste toner case full sensor normal? NO: Correct the connector or wiring.
Waste toner case full sensor	3) Try replacing the waste toner case full sensor. Is the fault corrected? YES: End.
Drum unit, DC controller PCB	4) Try replacing the drum unit. Is the problem corrected? YES: End. NO: Replace the DC controller PCB.

3.4.15 The 'Controller Card Set' message does not go ON.

3.4.16 The 'Control Card Set' message does not go OFF.

Connector	1) Is the connector (J210) on the image processor PCB normal? NO: Correct the connection.
Connector	2) Is the dummy connector removed? It is expected to be removed at time of installation. NO: Remove the connector.
DC controller PCB	3) Try replacing the control card or the card reader. Is the fault corrected? YES: Replace the control card or the card reader. NO: Replace the image processor PCB.

3.5 Troubleshooting Feeding Faults

3.5.1 Outline

A jam, if it occurs in the machine, tends to occur in any of the following locations:

1. pickup assembly
2. transfer/feeding assembly
3. fixing/delivery assembly

The tables that follow are arranged according to location; you can also find out the nature of any jam by making the following selections in service mode: #10 REPORT>JAM/ERR LOG REPORT.

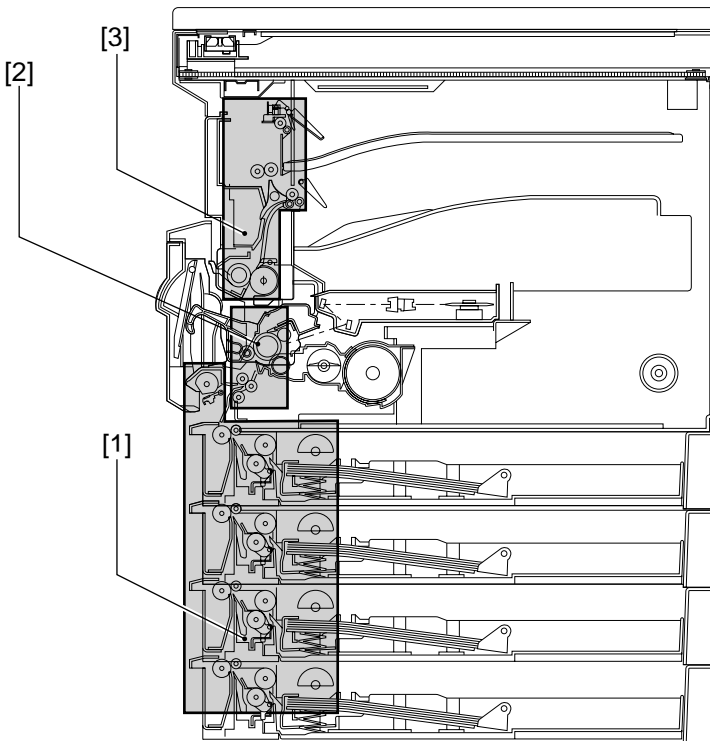

F13-305-01

3.5.2 Pickup Assembly

Machine state	<p>1) Do the pickup roller of the selected paper source (cassette, manual feed tray) and the feed roller of the cassette rotate during printing? NO: See "Pickup operation fails" for each source of paper.</p>
Cassette	<p>2) Is the cassette fitted correctly? Is the paper size lever set correctly? NO: Correct the fault.</p>
Cassette	<p>3) Try a different cassette. Is the fault correct? YES: Check the faulty cassette.</p>
Paper	<p>4) Is the paper curled or wavy? YES: Replace the paper. Advise the user on the correct method of storing paper.</p>
Paper	<p>5) Try paper of a type recommended. Is the fault corrected? NO: Advise the user to use recommended paper.</p>
Roller	<p>6) Is the surface of the pickup roller of the cassette and manual feed tray and the feeding roller of the cassette normal? YES: Check the sensor lever of the retry sensor (PS152) and registration paper sensor (PS101). NO: Clean the rollers. If damage/deformation is found, replace it.</p>

3.5.3 Transfer/Feeding Assembly

Paper	<p>1) Try paper of a recommended type. Is the fault corrected? YES: Advise the user to use recommended paper.</p>
Paper	<p>2) Is the paper curled or wavy? YES: Replace the paper. Advise the user on the correct method of storing paper.</p>
Feeding assembly	<p>3) Is there foreign matter/burrs in the feeding assembly? YES: Remove it. Or, correct the fault.</p>
Sensor	<p>4) Is there paper over any of the sensors used to detect a jam? Or, are the flag and the wiring of the sensor normal?</p> <ul style="list-style-type: none"> • retry sensor (PS152) • registration paper sensor (PS101) • delivery sensor (PS103) <p>YES: Remove it. Or, correct the fault. If the fault cannot be corrected, replace the sensor.</p>
Registration clutch (CL101)	<p>5) Check the wiring from the connector J106 on the DC controller PCB to the registration clutch (CL101). Is it normal? NO: Correct the connection of the connectors.</p>
Registration clutch	<p>6) Try replacing the registration clutch. Is the problem corrected? YES: End. NO: Replace the DC controller PCB.</p>

3.5.4 Fixing/Delivery Assembly

Machine state	<p>1) Is the machine equipped with an inner 2-way tray? Is the jam in the delivery tray A (No. 2 delivery slot)? NO: Go to step 3.</p>
2-way solenoid, wiring	<p>2) Are the 2-way solenoid and the wiring to the solenoid normal? NO: Correct the fault.</p>
Sensor	<p>3) Is there paper over any of the following sensors? Also, are the flag and wiring for the sensor normal?</p> <ul style="list-style-type: none"> • retry- sensor (PS152) • registration paper sensor (PS101) • delivery sensor (P103) • No. 2 delivery sensors (PS201; for inner 2-way tray) <p>YES: Remove the paper. Or, correct the fault.</p>
Fixing assembly	<p>4) Try replacing the fixing assembly. Is the problem corrected? YES: End. NO: Replace the DC controller PCB.</p>

3.5.5 Feeding Fault (double feeding)

Paper	<p>1) Is there more paper than allowed in the cassette (250 sheets)? YES: Advise the user not to put more paper than allowed in the cassette.</p>
Paper	<p>2) Is the paper curled or wavy? YES: Replace the paper. Advise the user on the correct method of storing paper.</p>
Machine state	<p>3) Does the fault occur when the cassette is used as the source of paper? NO: Go to step 5.</p>
Separation claw, Torque limiter	<p>4) Is the separation claw of the cassette deformed? YES: Correct the fault. If the fault cannot be corrected, replace the separation roller. NO: Replace the torque limiter.</p>
Multifeeder tray	<p>5) Is the manual feed separation pad worn? YES: Replace the separation pad. NO: Replace the separation pad pressure spring.</p>

3.5.6 Feeding Faults (wrinkling)

Pickup assembly	<p>1) Turn off the power while paper is moving through the feeding assembly. At this time, is the paper wrinkled? Or, is it moving askew? YES: Check the rollers of the pickup assembly and the registration roller.</p>
Paper	<p>2) Try paper fresh out of package. Is the fault corrected? YES: The paper may be moist. Advise the user on the correct method of storing paper.</p>
Paper	<p>3) Try paper of a recommended type. Is the problem corrected? NO: Advise the user to use recommended paper.</p>
Fixing assembly	<p>4) Execute fixing roller cleaning in user mode. Is the fault corrected? YES: End. NO: Replace the fixing assembly.</p>

4 Arrangement and Functions of Electrical Parts

4.1 Outline

4.1.1 Outline

This section provides a diagram showing the arrangement of the machine's and its accessories' electrical parts together with a listing.

The machine comes in two types: 1-cassette type and 2-cassette type. The 2-cassette type is configured based on the 1-cassette type with the addition of a 1-cassette unit.

This section uses the 1-cassette type for discussions; for the 2-cassette type, see additionally the discussions for the 1-cassette unit.



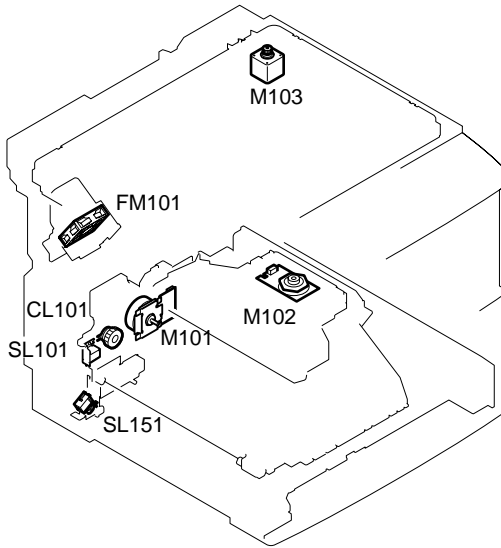

4.1.2 Checking the Sensors

The photointerrupters may be checked using 'SENSOR' under 'TEST MODE' in service mode (6-3: SENSOR). (For specific instructions, see 5.5.7 of Chapter 13.)

4.2 Clutches, Solenoids, Motors, and Fans

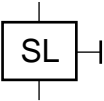

F13-402-01

Symbol	Name	Notation	Description
	Motor	M101	Main motor
		M102	Scanner motor
		M103	Reader motor
	Clutch	CL101	Registration clutch
	Solenoid	SL101	Multifeeder pickup solenoid
		SL151	Cassette pickup solenoid
	Fan	FM101	Heat discharge fan

4.3 Sensors

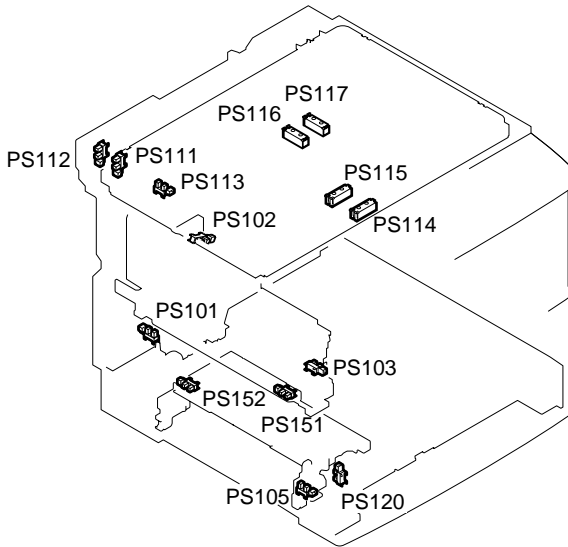

F13-403-01

Symbol	Name	Notation	Function
	Sensor	PS101	Registration paper sensor
		PS102	Paper full sensor
		PS103	Delivery sensor
		PS105	multifeeder paper sensor
		PS111	Copyboard cover open/closed sensor
		PS112	ADF open/closed sensor
		PS113	CS unit HP sensor
		PS114	Original size sensor 1
		PS115	Original size sensor 2
		PS116	Original size sensor 3
		PS117	Original size sensor 4
		PS120	Waste toner case full sensor
		PS151	Cassette paper sensor
		PS152	Retry sensor

4.4 PCBs

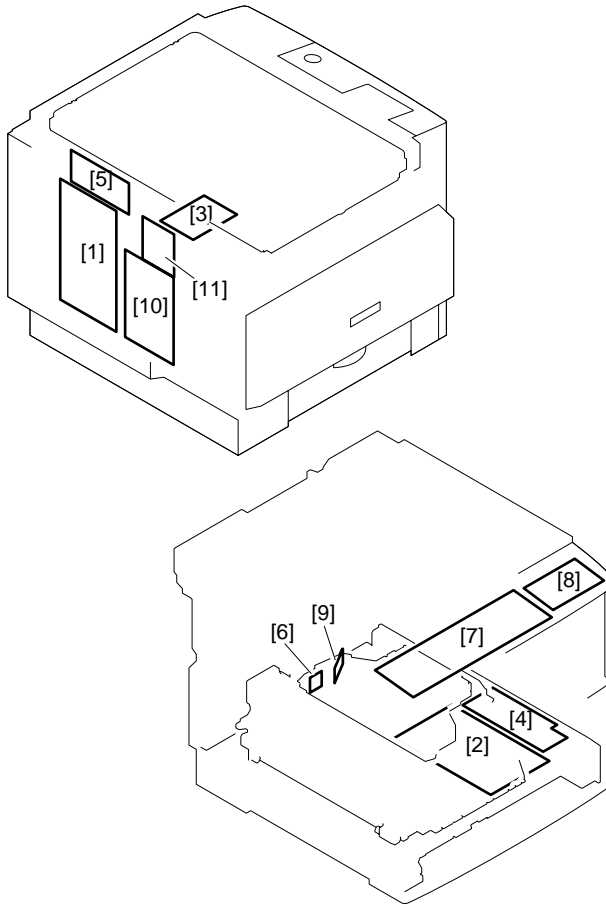

F13-404-01





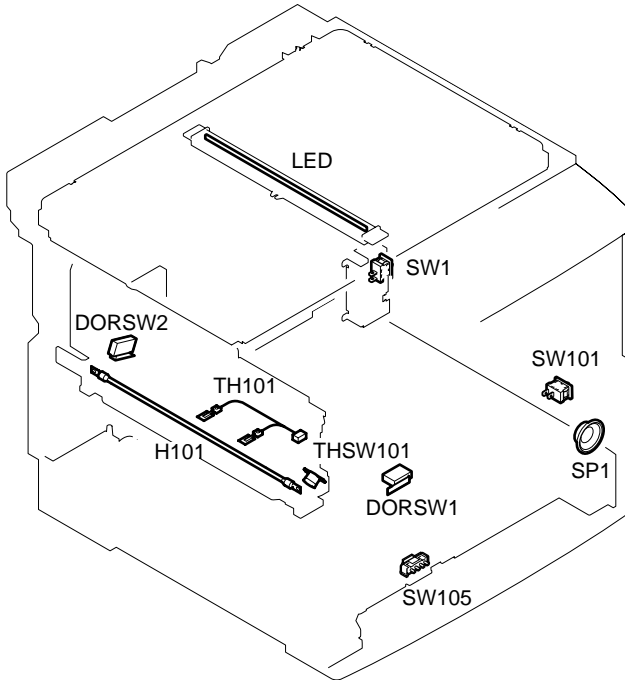

Symbol	Name	Description
[1]	Image processor PCB	Image processing, sequence control
[2]	DC controller PCB	DC load control, high voltage control
[3]	Analog processor PCB	CS unit control, image processing
[4]	Power supply PCB	DC power supply generation
[5]	Original detecting/ reader motor driver PCB	Original detection, motor drive
[6]	BD detection PCB	Laser beam detection
[7]	Control panel PCB 1	Control panel control
[8]	Control panel PCB 2	Control panel control
[9]	Laser unit	Laser drive
[10]	Printer board*1	Image processing/interface connection
[11]	Network interface board*1	Network connection

*1: if equipped with printer functions.

4.5 Switches, Others

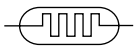

F13-405-01

Symbol	Name	Notation	Function
	Switch	SW101 SW105 DORSW1 DORSW2	Power switch Cassette paper size switch Front cover switch Left cover switch
	LED	LED	Contact sensor
	Thermistor	TH101	Thermistor
	Thermal switch	THSW101	Thermal switch
	Heater	H101	Fixing heater
	Speaker	SP1	Speaker

4.6 Cassette Unit

- 1-Cassette Unit

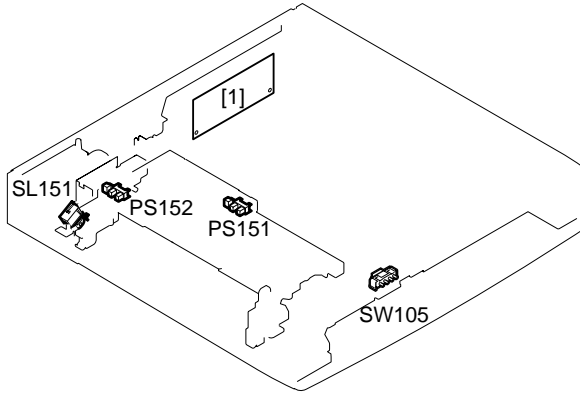

F13-406-01

- 2-Cassette Unit

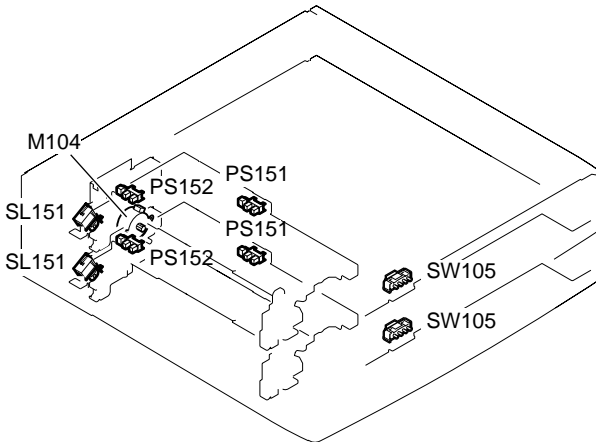

F13-406-02

• 3-Cassette Unit

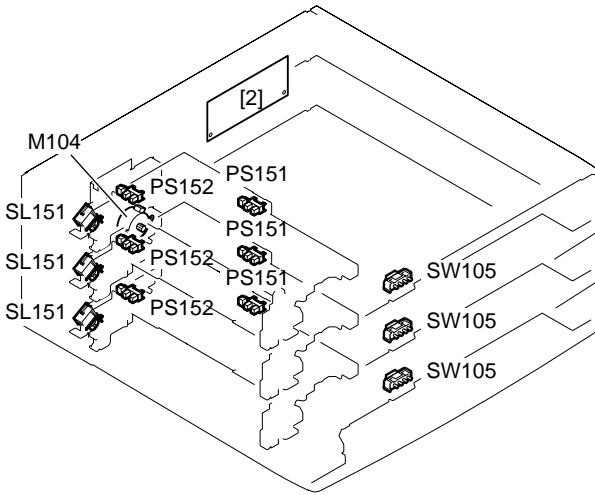

F13-406-03

Symbol	Name	Notation	Description
	Sensor	PS151 PS152	Cassette paper sensor Retry sensor
	Switch	SW105	Cassette paper size switch
	Solenoid	SL151	Cassette pickup solenoid
	Motor	M104	Pickup motor
Ref.	Name	Description	
[1]	1-cassette unit controller PCB	Sequence control	
[2]	2/3-cassette unit controller PCB	Sequence control	

4.7 Inner 2-Way Tray

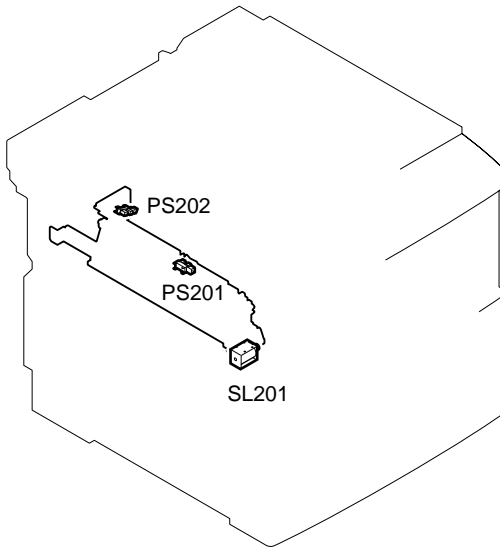

F13-407-01

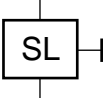
Symbol	Name	Notation	Description
	Sensor	PS201	No. 2 delivery sensor
		PS202	No. 2 full detection sensor
	Solenoid	SW105	No. 2 delivery solenoid

4.8 Variable Resistors (VR), Light-Emitting Diodes (LED), and Check Pins

Of the VRs, LEDs, and switches found in the machine, those used in the machine are discussed.



1. Some of the LEDs emit dim light when they are off because of leakage current; this is a normal condition, and must be kept in mind.

2. VRs that may be used in the field



VRs that must not be used in the field



Those VRs and check pins not discussed herein are for use at the factory only, and must not be used in the field, as they require special tools and high precision.

4.8.1 Image Processor PCB

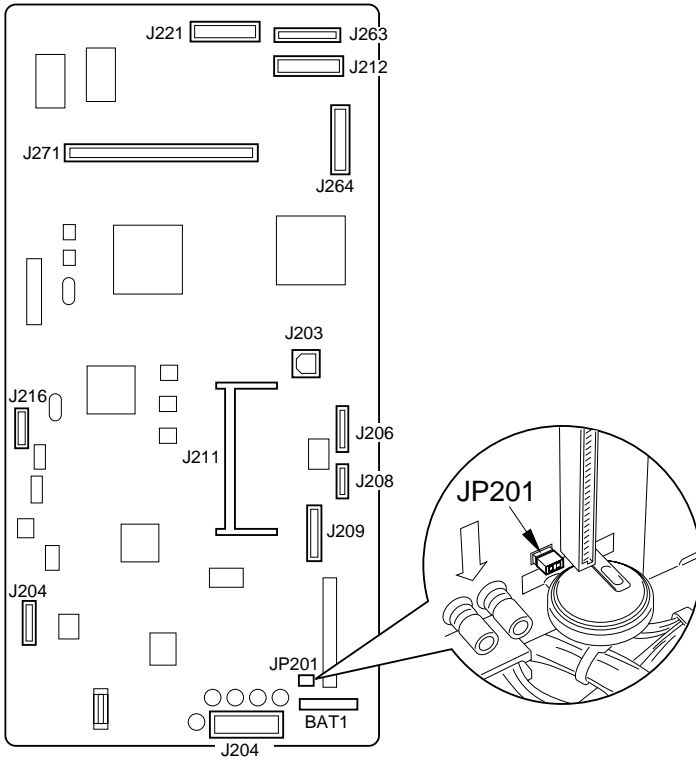

F13-408-01

JP201: jumper wire for the battery (BAT1) used to back up the memory for control data (user data, service data).

BAT1: battery used to back up control data (service mode data, user mode data).

4.8.2 DC Controller PCB

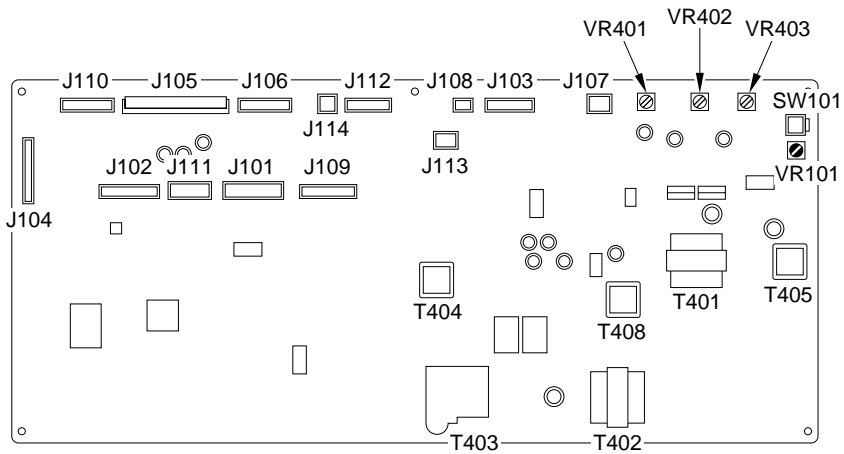

F13-408-02

- VR101 : volume for adjustment of leading edge
- VR401 : for factory (volume for adjusting high-voltage power supply reference voltage)
- VR402 : for factory (volume for adjusting toner level detection reference)
- VR403 : for factory (volume for adjusting toner level detecting antenna)
- SW101 : test print switch

4.8.3 Power Supply PCB

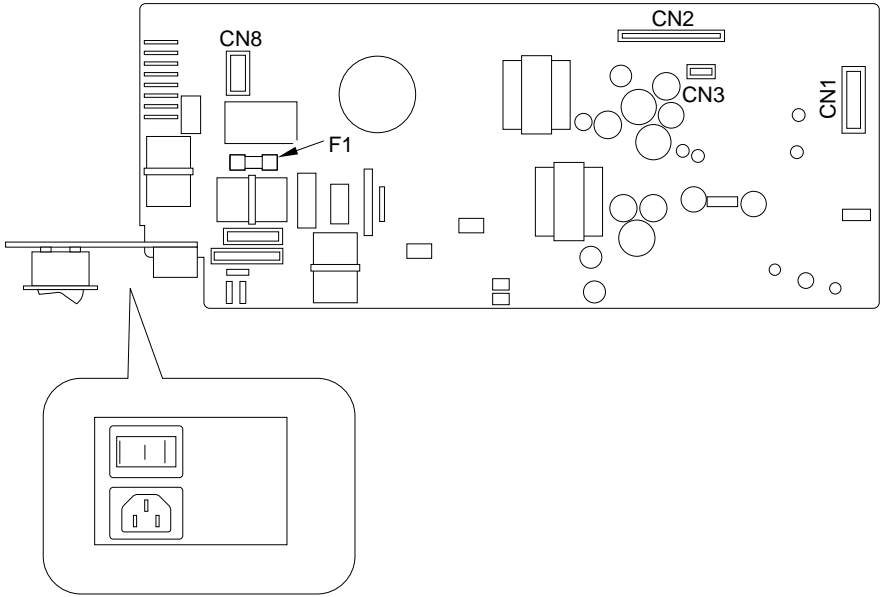

F13-408-03

4.8.4 Analog Processor PCB

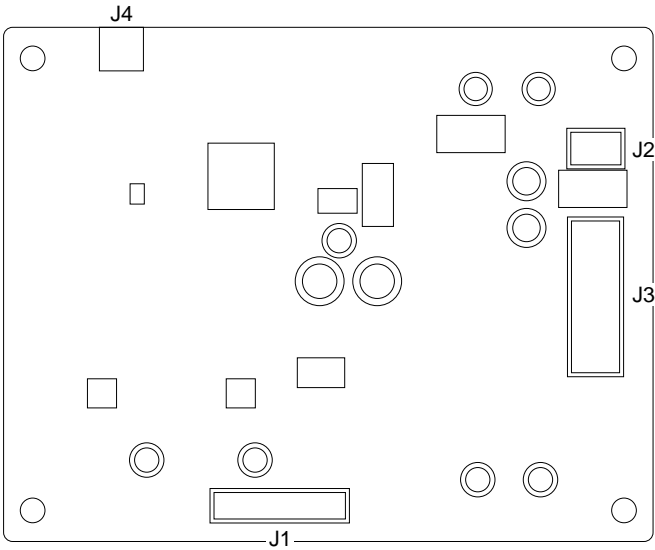

F13-408-04

4.8.5 1-Cassette Unit Controller PCB

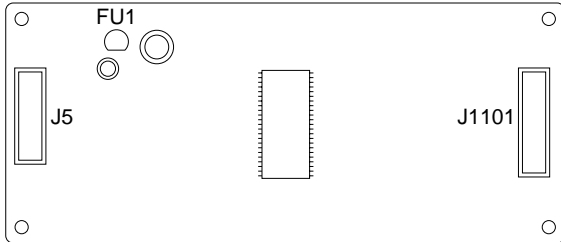

F13-408-05

4.8.6 2/3-Cassette Unit Controller PCB

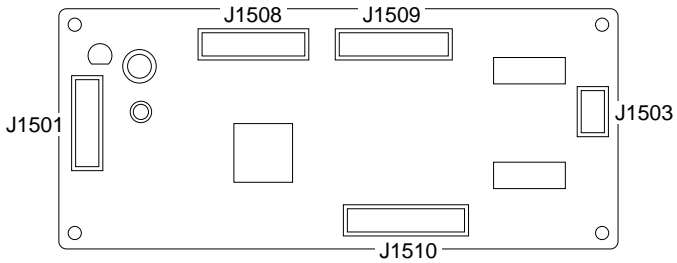

F13-408-06

5 Service Mode

5.1 Outline

The items that follow may be checked/set using the machine's service mode, which is designed the way the service mode used in fax machines is designed in terms of contents and operation. The machine's service mode consists of the following 13 blocks.

As many as 11 items (#1 through #14) are offered, including test mode (TEST MODE).

#1 SSSW : service soft switch

Use it to make settings related to counter functions.

#2 MENU : Not used.

#3 NUMERICParam : Use it to select count types.

#4A SPECIAL : Not used.

#4B NCU : Not used.

#4C ISDN : Not used.

#5 TYPE : country setting

Use it to make collective settings related to user data and service mode (#1 SSSW, #3 Numeric Param.) to suit the country of installation indicated on the display.

#6 SCANNER : (partly available in service mode)

Do not use it except for '7: CCD' at time of adjusting image position; a change to the setting can adversely affect the read image quality.

#7 PRINTER : printer settings

Use it to make registration/settings related to basic printer functions.

#8 PDL : Do not use.

#9 COUNTER : counter indication

Use it to check estimates for maintenance/parts replacement.

#10 REPORT : report output

Use it to generate reports on various service data.

#11 DOWNROAD : download

Use it to download firmware to the ROM of a PCB in question.

#12 CREAL : data initialization mode setting

Use it to reset various data to initial settings.

#13 ROM : ROM control

Use it to check the version of the CPU and the ROM DIMM on a PCB in question.

#14 CS SET : CS unit position

Use it to change the CS unit back to its position at time of shipment.

5.2 Using the Mode

To use a service mode item, go through the following flow of operation:

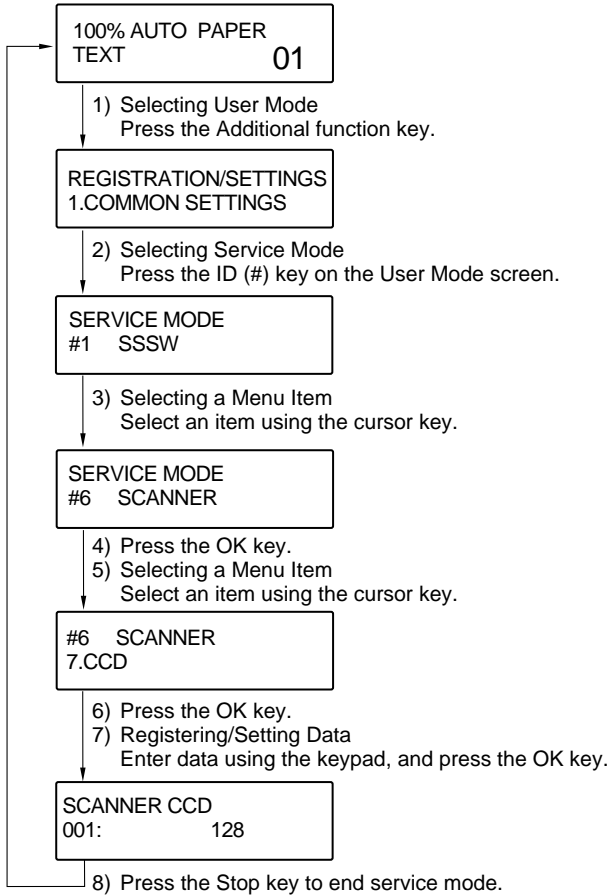

F13-502-01

5.3 Service Mode Menus

The initial settings are boldfaced.

service data				
#1 SSSW	SW33	00000000	counter-related	
(service soft switch setting)				
#2 MENU	not used			
(menu switch setting)				
#3 NUMERIC Param.	(numerical parameters setting)	Initial setting		
		056 :	101	total 1 indication
		057 :	103	total (L) indication
		058 :	201	copy (total 1) indication
		059 :	203	copy (L) indication
		060 :	0	no indication
061 :	0	no indication		
#4A SPECIAL	not used			
#4B NCU	not used			
(NCU setting)				
#4C ISDN	not used			
#5 TYPE				
(type setting)				

F13-503-01



-
- #1 SSSW : do not change except SW33; the rest are not used.
 - #2 MENU : do not change; it is not used.
 - #3 Numerical Param. : Do not change except 056 through 061; the rest are not used.
 - #4 : do not change; it is not used.
 - #5 TYPE : when a country/region is selected (indicated on the display), the settings related to items #1 SSSW, #3 Numeric Param, and user data will collectively be set.
-

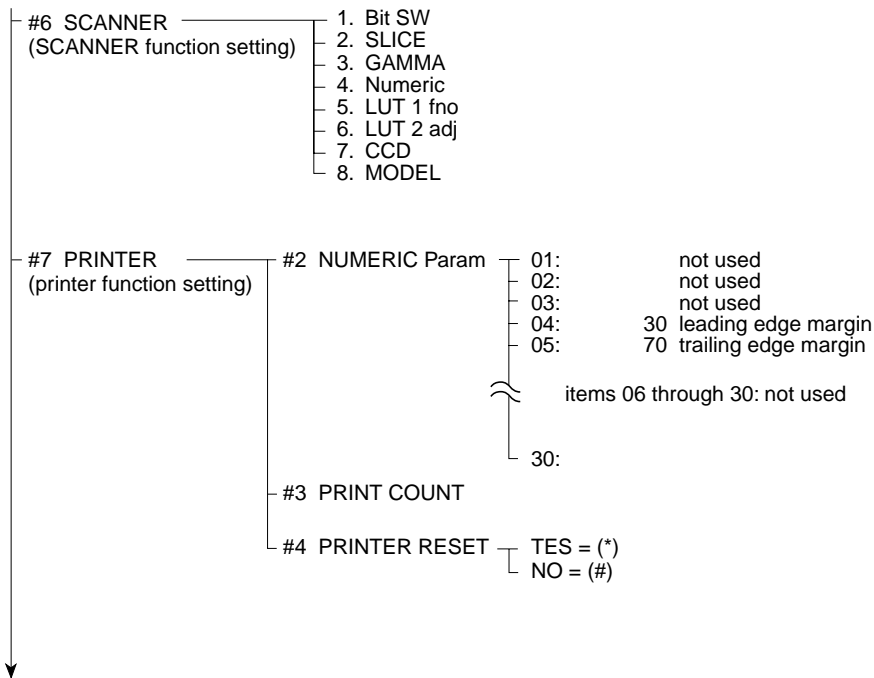

F13-503-02



#6 SCANNER (scanner function settings)

The setting of this item can adversely affect the read image quality. '7. CCD' is changed when adjusting the image position and '8. MODEL' is changed when replacing the image processor PCB; otherwise, this item must not be changed.

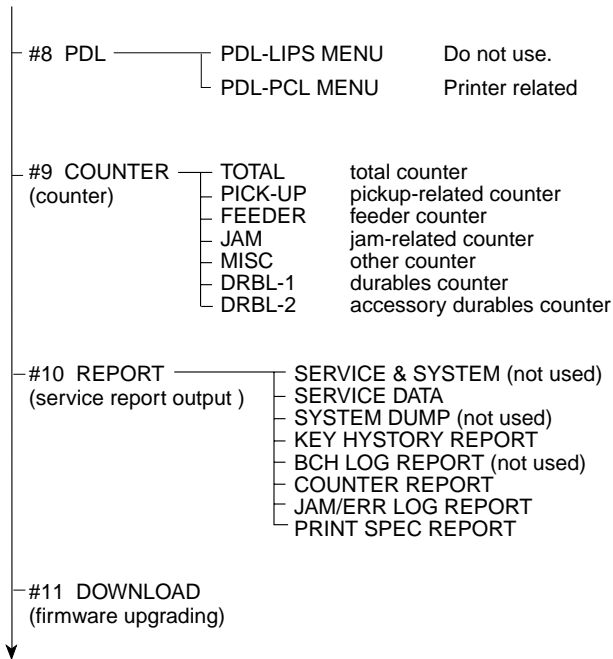

F13-503-03

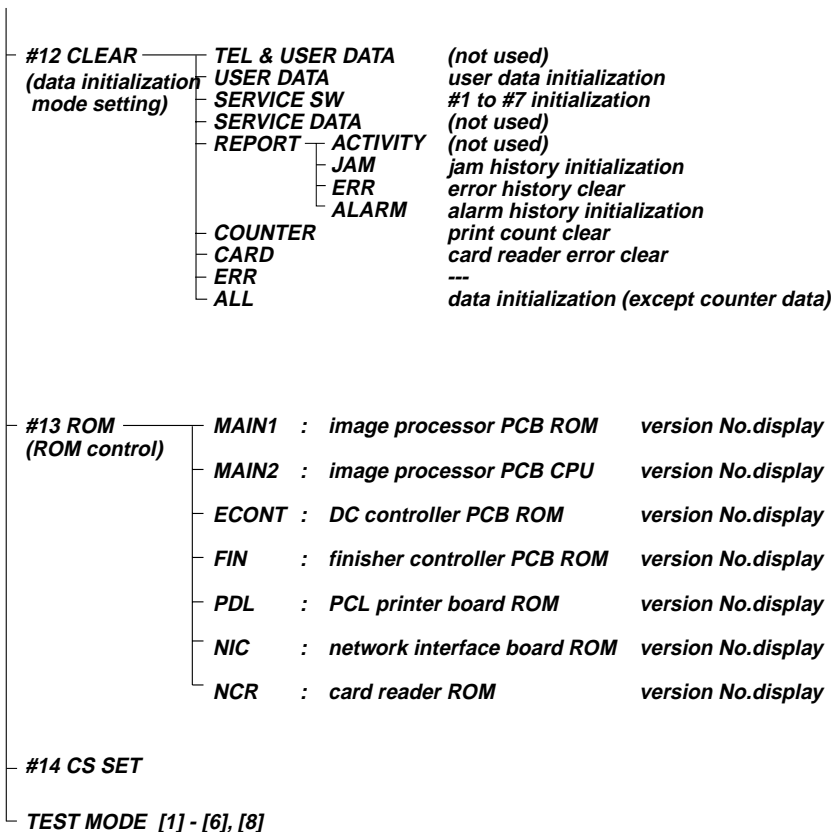

F13-503-04

5.4 Setting the parameters

5.4.1 Registering the Bit Switch (#1 SSSW)

Each item of registration/setting of this switch is based on the position of its 8 bits. It is indicated as shown below, and each bit is either '0' or '1'.



Do not use service data indicated as 'not used', since it must be used as it is initially set.

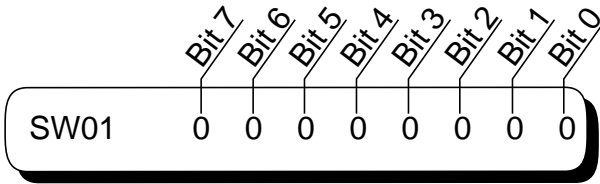

F13-504-01

#1 SSSW-SW33:counter-related

Bit	Function	1	0	Factory setting
0	count B4 as large size	yes	no	0
1	indicate serial No. on counter check screen	yes	no	0
2	no used	-	-	
3	no used	-	-	
4	no used	-	-	
5	no used	-	-	
6	no used	-	-	
7	no used	-	-	

[bit 0]

Use it to specify whether B4 paper should be counted as large-size paper.

If 'yes' is selected, B4 paper will be counted as large-size paper. If 'no' is selected, on the other hand, B4 paper will be counted as small-size paper.

[bit 1]

Use it to specify whether to indicate the machine serial No. on the Counter Check screen, appearing when the Counter key is pressed.

If 'yes' is selected, the serial No. will be indicated. If 'no' is selected, on the other hand, the serial No. will not be indicated.

5.4.2 Setting Numeric Parameters (#3 NUMERIC Param.)

Use it to change the contents/settings of the display items of the soft counters, which may be checked in the control panel by pressing the Counter key (by the user).

No.	Function	Initial	Remarks
56	count type select 1	101	total 1
57	count type select 2	103	total (L)*
58	count type select 3	201	copy (total 1)
59	count type select 4	203	copy (L)*
60	count type select 5	0	-
61	count type select 6	0	-

T05-504-02

*indicates large size (B4 or larger).

[No. 56 through 61]

Use it to select the count type indicated on the Counter Check screen, which appears in response to a press on the Counter key.

When '0' is selected, counter 1 will not be indicated.

No. 56 : use it to select a count type for the counter 1 reading.

No. 57 : use it to select a count type for the counter 2 reading.

No. 58 : use it to select a count type for the counter 3 reading.

No. 59 : use it to select a count type for the counter 4 reading.

No. 60 : use it to select a count type for the counter 5 reading.

No. 61 : use it to select a count type for the counter 6 reading.

If above selections have been made, the counters will be displayed in order of counter numbers.

<Soft Counter Specifications>

The soft counters are classified as follows according to input numbers:

100s : total

200s : copy

300s : print

500s : scan

700s : received print

800s : report print

Guide to the Table

√ : available for the machine.

large size (B4 or larger)

small size (smaller than B4)

total 1 (all sizes as 1)

total 2 (all sizes as 2)

1 or 2 under “Counter” : count increments for large-size paper

To make a change so that B4 and larger papers will be counted as large-size, use service mode: make the following selections, and change bit 0 to ‘1’: #1SSSW>SW33.

Setting		Basic counter											
		Copy		PDL print		Received print		Report print		Scan			
		Large	Small	Large	Small	Large	Small	Large	Small	Large	Small	Large	Small
total	total 1	101	√	√	√	√	√	√	√	√	√		
	total 2	102	√	√	√	√	√	√	√	√	√		
	large	103	√		√		√		√		√		
	small	104		√		√		√			√		
copy	total 1	201	√	√									
	total 2	202	√	√									
	large	203	√										
	small	204		√									
print	total 1	301			√	√			√		√		
	total 2	302			√	√			√		√		
	large	303			√				√				
	small	304				√					√		
PDL	total 1	331			√	√							
	total 2	332			√	√							
	large	333			√								
	small	334				√							
received print													
	total 1	701					√	√					
	total 2	702					√	√					
	large	703					√						
	small	704						√					
report print													
	total 1	801							√		√		
	total 2	802							√		√		
	large	803							√				
	small	804									√		
scan	total 1	505										√	√
	total 2	506										√	√
	large	507										√	
	small	508											√

5.4.3 Selecting the Country/Region of Installation (#5 TYPE)

When you select a country of installation from the list indicated on the display, the appropriate service mode settings (#1 SSSW, #3 Numeric Param.) and the user data standard settings will collectively be selected.

5.4.4 Setting Original Read Functions (#6 SCANNER)

Item	Description
1. Bit SW	Do not change. A change to the setting can adversely affect the read image quality.
2. SLICE	
3. GAMMA	
4. Numeric	
5. LUT 1 fno	
6. LUT 2 adj	
7. CCD	Some settings may be changed.
8. MODEL	Used to turn on/off the original detection function.

#6 SCANNER-7

No.	Function	Range Unit	Default
0 to 17	Do not change.	-	-
18	CS read start adjustment (for ADF read)	0 to 9999 unit : 0.1mm	470
19	shading position adjustment	0 to 9999 unit : 0.1mm	90
20	CS wobble correction distance (for ADF read)	0 to 9999 unit : 0.1mm	40
21	main scanning direction image read start position adjustment (for book read)	0 to 9999 unit : 0.04mm	128
22	main scanning direction image read start position adjustment (for ADF read)	0 to 9999 unit : 0.04mm	128
23	sub scanning direction image read start position adjustment (for book read)	0 to 9999 unit : 0.1mm	145
24	sub scanning direction read start position adjustment (for ADF read)	0 to 9999 unit : 0.1mm	235
25	sub scanning direction image read end position correction (for copy)	0 to 9999 unit : 0.1mm	52
26 to 28	Do not change.	-	-
29	main scanning direction image read ratio correction (for book read)	0 to 9999 unit : 0.1%	16
30	main scanning direction image read ratio correction (for ADF reading)	0 to 9999 unit : 0.1%	16
31	sub scanning direction image read ratio correction (for book read)	0 to 9999 unit : 0.1%	16
32	sub scanning direction image read ratio correction (for ADF read)	0 to 9999 unit : 0.1%	16
34	feed motor speed adjustment (for ADF read)	0 to 9999 unit : 0.1%	50

[No. 18, 20, 34]

Do to use in the field. However, if you are replacing the image processor PCB, be sure to enter the value used at the factory.

[No. 19]

Use it to adjust the shading position correction to set a level between '90' and '72' when the output has white lines (vertical).

[No. 21]

Use it to adjust the image read start position in main scanning direction for book read mode. A higher setting will decrease the margin on the left.

[No. 22]

Use it to adjust the image read start position in main scanning direction for ADF read mode. A higher setting will decrease the margin on the left.

[No. 23]

Use it to adjust the image read start position in sub scanning direction for book read mode. A higher setting will decrease the margin along the image leading edge.

[No. 24]

Use it to adjust the image read start position in sub scanning direction for ADF read mode. A higher setting will decrease the margin along the image leading edge.

[No. 25]

Use it to correct the image read end position in sub scanning direction for copy mode. A higher setting will decrease the margin along the image trailing edge.

[No. 29]

Use it to correct the image read ratio in main scanning direction for book mode. A higher setting will lengthen the image in main scanning direction.

[No. 30]

Use it to correct the image read ratio in main scanning direction for ADF mode. A higher setting will lengthen the image in main scanning direction.

[No. 30]

Use it to correct the image read ratio in sub scanning direction for ADF mode. A higher setting will lengthen the image in sub scanning direction.

[No. 31]

Use it to correct the image read ratio in sub scanning direction for book mode. A higher setting will lengthen the image in sub scanning direction.

[No. 32]

Use it to correct the image read ratio in sub scanning direction for ADF mode. A higher setting will lengthen the image in sub scanning direction.

#6 SCANNER-8 MODEL

If you select 'TYPE A' for '8. MODEL', the original size detecting function will not be used; if you select 'TYPE B' on the other hand, the original size detection function will be used.



If you replaced the image processor PCB of a model equipped with an original detection function, be sure to select 'TYPE B' for '10. MODEL'. Otherwise, you will not be able to use the original size detection function when the machine is in book mode. If the machine is not equipped with an original detection function, on the other hand, check to make sure that the selection is 'TYPE A'.

5.4.5 Setting the Printer Parameters (#7 PRINTER)

Item	Description
#2 NUMERIC Param	Use it to set the margin for paper.
#3 PRINT COUNT	Use it to indicate the number of prints.
#4 PRINTER RESET	Use it to reset the machine at time of an error in the fixing assembly, thereby clearing the error.

#7 PRINTER-#2 NUMERIC Param. (setting numerical parameters)

No.	Function	Range	Unit	Factory
0 to 3	not used	-	-	-
4	leading edge margin	0 to 9999	unit : 0.1mm	30
5	trailing edge margin	0 to 9999	unit : 0.1mm	70
6 to 30	not used	-	-	-

[No. 4]

Use it to set the margin along the leading edge of paper.

[No. 5]

Use it to set the margin along the trailing edge of paper.

#7 PRINTER-#3 PRINT COUNT

Use it to indicate the number of prints and the total number of prints.

#7 PRINTER-#4 PRINT RESET

Use it to reset the machine if 'E000' through 'E004' (error in fixing assembly) is indicated, thus clearing the error.

5.4.6 PDL (#8 PDL)

See to PCL printer board service manual.

5.4.7 Counters (#9 COUNTER)

The machine is equipped with counters for periodically replaced parts and durables (DRBL-1/DRBL-2), providing estimates of when to replace the durables.

Small-size paper is counted for '1', while large-size paper is counted for '2'.

The following are items under COUNTER:

Level 1	Level 2	Level 3	Description
COUNETR	TOTAL	(total counter)	
		SERVICE1	total counter 1 for service
		SERVICE2	total counter 2 for service
		TTL	total counter
		COPY	total copy counter
		PDL-PRT	PDL print counter
		FAX-PRT	fax reception print counter (Not used)
		RPT-PRT	report print counter
		SCAN	scanner counter
	PICK-UP	(pickup-related counter)	
		C1	cassette 1 pickup counter
		C2	cassette 2 pickup counter
		C3	cassette 3 pickup counter
		C4	cassette 4 pickup counter
		MF	multifeeder tray pickup counter
	FEEDER	(feeder-related counter)	
		FEED	feed pickup total counter

Level 1	Level 2	Level 3	Description
COUNETR	JAM	(jam counter) TTL FEEDER SORTER MF C1 C2 C3 C4	total jam counter for machine jam counter for feeder (ADF) jam counter for sorter (finisher) manual feed tray jam counter cassette 1 jam counter cassette 2 jam counter cassette 3 jam counter cassette 4 jam counter
	DRBL-1	(machine durables) FX-UNIT TR-ROLL DV-UNT-C M-SP-RL M-SP-P-D	fixing assembly paper passage counter transfer charging roller paper passage counter developing assembly paper passage counter manual feed pickup roller paper passage counter manual feed separation pad paper passage counter
	DRBL-2	(accessories durables) FIN-STPR	finisher operation counter

a. Clearing the Counter

- All Clear of Maintenance/Parts Counter

Execute the following in service mode to clear all maintenance/parts counter readings:
#12 CLEAR>COUNTER.

- Clearing Counter Readings When Replacing Parts

Indicate the counter reading of the part you have replaced, and press the Clear key (individual clearing).



Generating a Counter Report

You can generate a counter report by executing the following in service mode: #10 REPORT>COUNTER REPORT.

5.4.8 Generating a Report (#10 REPORT)

Any of the following report may be generated:

Report	Description
SERVICE & SYSTEM	Not used.
SERVICE DATA	service mode #1 through #7, #13, start data.
SYSTEM DUMP	Not used.
KEY HISTORY REPORT	1800 key presses since most recent report.
BCH LOG REPORT	Not used.
COUNTER REPORT	maintenance/parts counter readings. changes to user data/service data defaults. system dump list
JAM/ERR LOG REPORT	jam, error, alarm histories
PRINT SPEC REPORT	TYPE settings, memory size, ROM indications, adjustment data

5.4.9 Downloading (#11 DOWNLOAD)

The machine allows upgrading of the following parts using the Service Support Tool (SST) for downloading; for details, see Chapter 14.

Machine:

- ROM DIMM and CPU on image processor PCB

Accessories:

- ROM on finisher controller PCB

5.4.10 Clear (#12 CLEAR)

The following items may be used in clear mode:

Item	Level 2	Description
TEL & USER DATA		Not used.
USER DATA		Use it to clear the user data. The SSSW settings will not be cleared. Use it to clear the settings of SSSW. The user data will not be cleared.
SERVICE SW		
SERVICE DATA REPORT		Not used.
	ACTIVITY	Not used.
	JAM	Use it to clear the contents of the jam history.
	ERR (E-CODE)	Use it to clear the contents of the error (E code) history.
	ALARM	Use it to clear the contents of the alarm history.
COUNTER		Use it to clear the maintenance/parts counter data.
CARD		Use it to clear the card reader error data.
ERR	E355 CLR	---
ALL		Use it to clear all settings/registration data except the counter (denominator, numerator).

5.4.11 ROM Indication (#13 ROM)

The following items/settings may be sued in ROM indication mode:

Item	Description
MAIN	Use it to indicate the version of the ROM on the image processor PCB.
MAIN2	Use it to indicate the version of the CPU on the image processor PCB.
ECONT	Use it to indicate the version of the ROM on the DC controller PCB.
PDL	Use it to indicate the version of the printer board.
NIC	Use it to indicate the version of the ROM on the network interface board.
FIN	Use it to indicate the version of the ROM on the finisher controller PCB.
NCR	Use it to indicate the version of the ROM on the card reader.

5.4.12 Resetting the CS Unit Position (#14 CS SET)

When you execute this mode, the CS unit moves to its position used at time of shipment. You may move the CS unit to a position where it is to be secured (right side) with the CS fixing screw.

5.5 Test Mode (TEST MODE)

5.5.1 Outline

Be sure to follow how menu items are indicated on the display when making use of test mode; the test mode menu items are grouped into 5 blocks:

1. D-RAM Test (1: DRAM)

Use it to find out whether data may be written to or read from the D-RAM normally.

2. CCD Test (2: CCD TEST)

Use it to correct variation in sensitivity among photo cells of the CCD.

3. PRINT Test (3: PRINT)

Use it to print 8 types of patterns within the print area in Fine mode.

4. FACULTY Test (6: FACULTY TEST)

Use it to check the operation of the micro switches, sensors, speakers, and ADF functions.

5. BOOK Test (8: BOOK TEST)

Use it to execute operation at a speed in keeping with read transmission image quality (LEDs).

5.5.2 Test Mode Menu

To start test mode, press the User Mode key and then the # key; select 'SERVICE MODE', and select 'TEST MODE' using the cursor key ◀ / ▶, and press the OK key.

To end test mode, press the Stop key and then the Clear key.

*Not used.

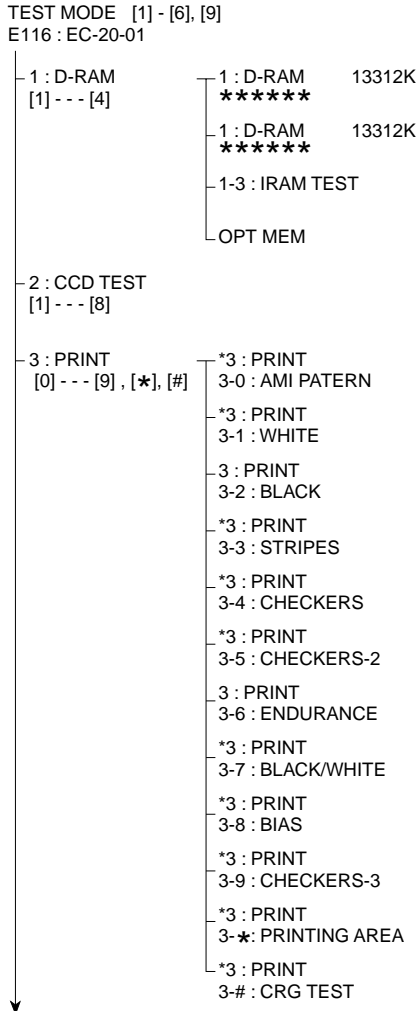

F13-505-01

*Not used.

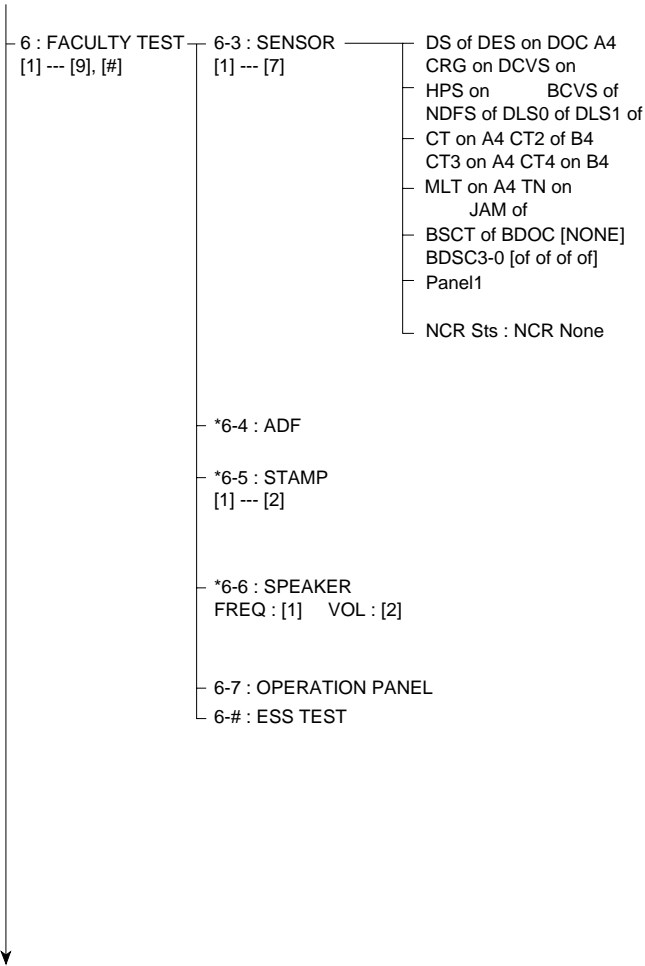

F13-505-02

*Not used.

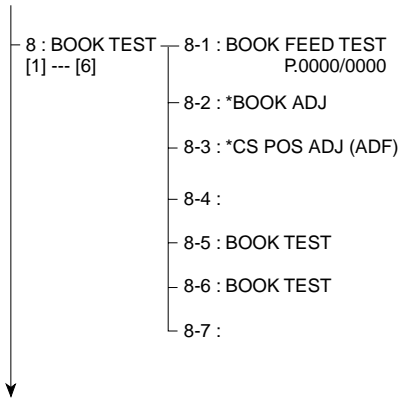

F13-505-03

5.5.3 D-RAM Test (1: D-RAM)

Press '1' on the keypad while the Test Mode menu is indicated to select D-RAM Test mode. Press '1' through '4' on the keypad in D-RAM Test mode for the following:

'1' on Keypad

Use it to check data write/read operations for the entire area of the D-RAM.

If an expansion memory (option) is mounted, its area will also be checked. If an error occurs during a check, the testing will be suspended, and an error will be indicated on the display.

'2' on Keypad

Use it to check data read operations for the entire area of the D-RAM.

If an expansion memory (option) is mounted, its area will also be checked. If an error occurs during a check, the testing will be suspended, and an error will be indicated on the display.

'3' on Keypad

Use it to check data read/write operations for the built-in RAM of the CPU.

'4' on Keypad

Use it to check data write/read operations for the expansion memory in the expansion slot (J271); memory size indication, for RAM area.

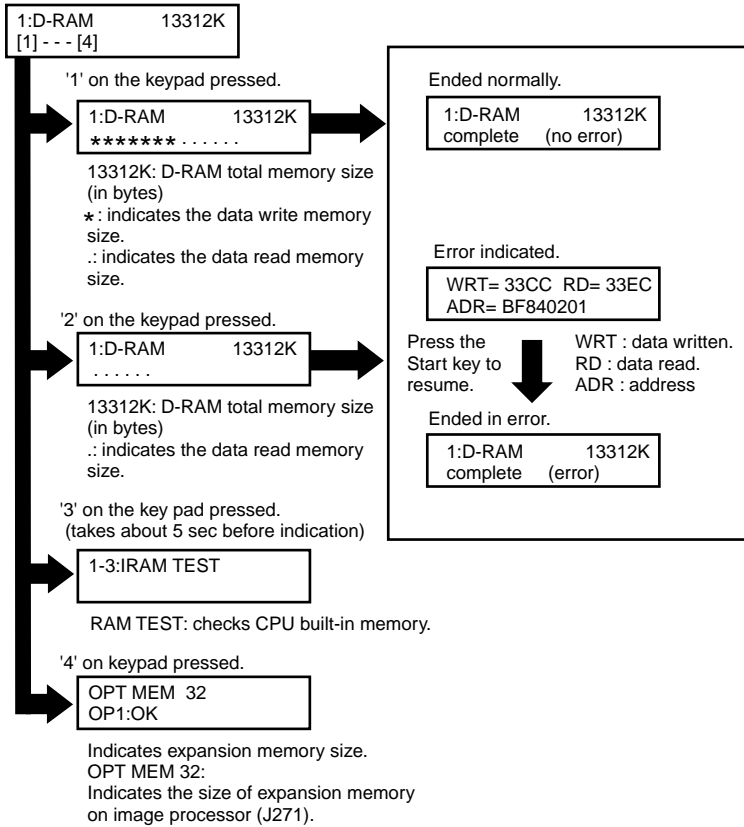

F13-505-04

5.5.4 CCD Test (2: CCD TEST)

A press on '2' on the keypad while the Test Mode menu is indicated will select CCD Test mode. Press '4', '7', or '8' on the keypad in test mode for the following; do not use other mode items, as they are for the factory/R&D:

'4' on Keypad

Use it to initialize the ADF read position parameter.

The settings will affect the following: service mode>#6 SCANNER>7. CCD>parameter 20, 22, 24 through 28, 30, 32, 34.

'7' on Keypad

Use it to initialize CS-related parameters.

The setting will affect the following: service mode>#6 SCANNER>7. CCD> parameters 1 through 8, 12.

'8' Keypad

Use it to execute gain auto adjustment, automatically correcting the CS output and setting the CS parameters. (For details, see 2.4.2 of Chapter 13.)

5.5.5 PRINT Test (3: PRINT)

Press '3' on the Test Mode menu to select PRINT TEST. Press '2' or '6' in the test mode to generate the following test patterns; do not use other than these 2 types, as the rest are for the factory/R&D:

'2' on Keypad

3-2: BLACK (totally black image)

'6' on Keypad

3-6: ENDURANCE (black band)

To stop test printing, press the Stop key.

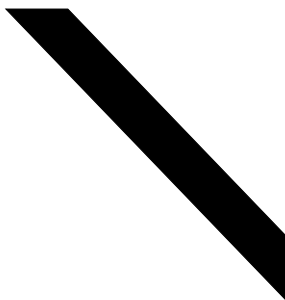

Use it to make sure that the print pattern does not have contraction/elongation of an image or dirt/black lines.

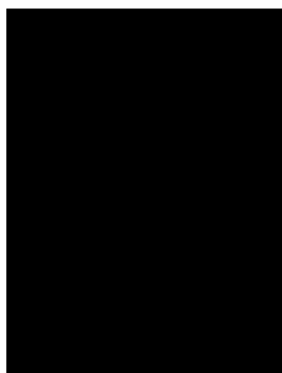

Use it to make sure that the print pattern does not have white lines or uneven image.

F13-505-05

5.5.7 Faculty Test (6: FACULTY TEST)

Press '6' on the keypad while the Test Mode menu is indicated to select Faculty Test. Press '3', '7', or 'C' in test mode to select the following menu:

Keypad	Item	Description
3	sensor test	sensor operation test
7	control panel test	control panel key operation test
C (clear key)	ESS test	ESS (energy save mode) operation test

Sensor Test (6-3: SENSOR)

Use it to check the state of the machine's sensor by referring to the display. Press '3' on the keypad while the Faculty test menu is indicated to select this mode; the display indication changes as each sensor is turned off/on.

6-3 : SENOR
[1] - - - [7]

'1' on the keypad pressed.

DS of DES of DOC A4
CRG on DCVS on

DS: original set sensor* (PI6); on/original present, of/original absent.

DES: read sensor* (PI8); on/original present, of/original absent.

DOC: original width sensor* (PI4, PI5); original width indicated based on ON/OFF combinations of 2 sensor states.

CRG: developing assembly sensor; on/of, developing assembly present/absent.

DCVS: door switch (DORSW1, DORSW2); on/paper not detected (front cover or left cover closed during standby), of/paper detected (front cover or left cover open during standby).

*ADF sensor state indicated.

'2' on the keypad pressed.

HPS on BCVS of
NDFS of DLS0 of DLS1 of

HPS: CS sensor HP sensor (PS113); on/CS unit in home position, of/CS unit not in home position.

BCVS: copyboard cover open/closed sensor (PS111, PS112); on/cover open, of/cover closed.

NDFS: length sensor 3* (PI3); on/original present, of/original absent.

DLS0: length sensor 2* (PI2); on/original present, of/original absent.

DLS1: length sensor 1* (PI1); on/original present, of/original absent.

'3' on the keypad pressed.

CT1 on A4 CT2 of
CT3 on A4 CT4 on B4

CT1: machine cassette paper sensor (PS151); on/paper present, of/paper absent.
machine cassette paper size detecting switch (PS151); on/paper present, of/paper absent.

CT2: 1st cassette paper unit paper sensor (PS151); on/paper present, of/paper absent.
1st cassette unit paper size detection switch (SW105); indicates paper size.

CT3: 2nd cassette unit paper sensor (PS151); on/paper present, of/paper absent.
2nd cassette unit paper size detecting switch (SW105); indicates paper size.

CT4: 3rd cassette unit paper sensor (PS151); on/paper present, of/paper absent.
3rd cassette unit paper size detecting switch (SW105); indicates paper size

'4' on the keypad pressed.

MLT on A4 TN on
JAM of

MLT: multifeeper paper sensor (PS105); on/paper present, of/paper absent.
indicates A4 or selected size.

TN: toner sensor; on/toner present, of/toner absent.

JAM: jam sensor; on/jam detected, of/jam not detected.

F13-505-06

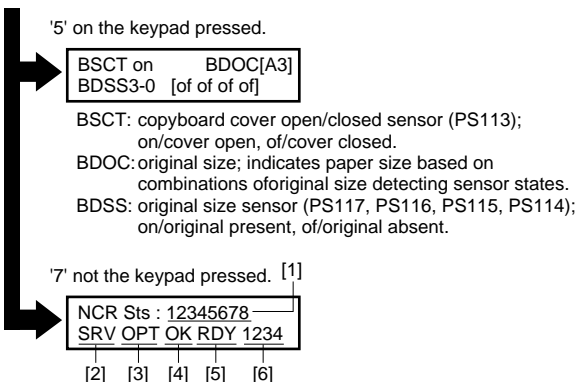

- [1] Indicates the presence/absence of the card reader/card.
if a card is present, the 8-digit card ID.
if no card is present, 'Card None'.
If the card reader is absent, 'NCR None'.
- [2] Indicates the type of card and the state of the card reader.
DPT : group card.
PRC : unit price setting card.
MAX : upper limit setting card.
ERS : erase card.
SRV : service card.
(no indication): card absent.
- [3] Indicates the type of card.
MGN : magnetic card.
OPT : optical card.
- [4] Indicates the status of reading.
OK : normal reading.
ERR : error reading.
NG : non-standard card.
- [5] Indicates the state of mode.
INI : in initialization.
RDY : ready.
- [6] Indicates the version of the card reader.
4-digit number.

F13-505-07

Control Panel Test (6-7: OPERATION PANEL)

Use it to check the operation of the control panel.

Press '7' on the keypad while the Faculty Test menu is indicated to select the Operation Panel Test menu, thereby executing the following:

- **Display Mode**

Press the Start key while the operation Panel Test menu is indicated to select Display Test Mode. In this mode, the display indicates the character.

Another press on the Start key will cause the display to be entirely black.

- **LED Lamp Test**

At the end of Display Test mode, press the Start key to select LED Lamp Test mode.

A press on the Start key will cause all lamps in the control panel to go ON.

- **Control Key Test**

At the end of LED LAMP Test mode, press the Start key to select the test for a specific key. Press the key corresponding to the character indicating on the display; the indication will go OFF if the key is normal.

When all character indications have gone OFF, test mode for the one-touch dial keys will start. Press each one-touch dial key so that its corresponding character will disappear from the display.

LED Lamp Test and Control Key Test (correspondence between characters and keys)

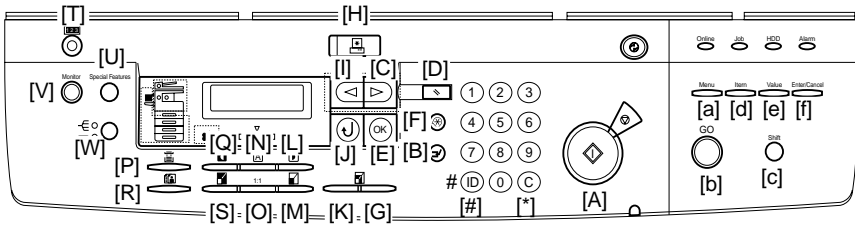

F13-505-08

Go through the following flow of work when testing the control panel:

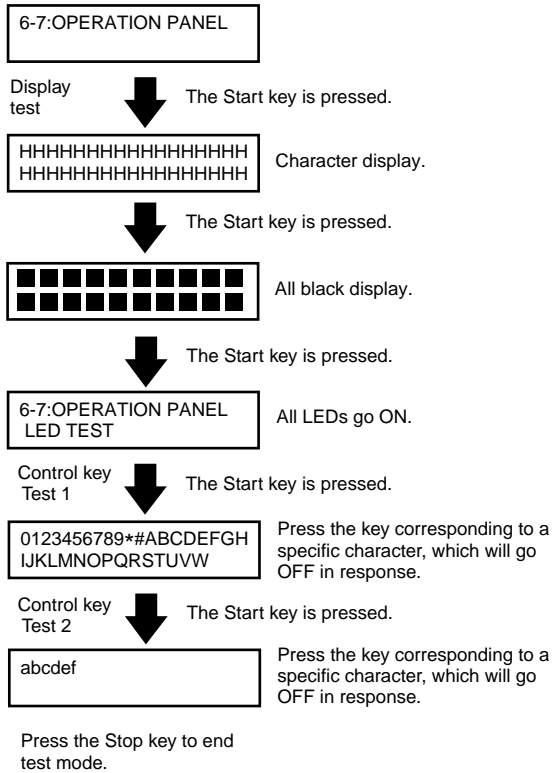

F13-505-09

ESS Test (6-#; ESS TEST)

Press the Clear key on the Faculty Test menu to execute ESS (energy save) test, in which the machine will start ESS mode and all except the ESS key LED in the control panel will go OFF. To end ESS mode,

- Press the ESS key.

5.5.8 Book Read Test (8: BOOK TEST)

Press '8' on the keypad while the Test Mode menu is indicated to select book test mode. Press on '4', '5', or '6' in test mode for the following:

'4' on Keypad

Press it to initialize the book read position parameter. The setting will affect the following in service mode: #6 SCANNER>7. CCD>parameters 21, 23.

'5' on Keypad

Press it to find out whether the contact sensor goes ON.

'6' on Keypad

Press it to initialize the book read position parameter. The setting will affect the following in service mode: #6 SCANNER>7. CCD> parameters 19 through 21, 23, 29, 31.

5.6 Report

5.6.1 User report

The following reports may be used in user mode:

Type	Description
DEPT. INFO LIST	Start user mode, and select '6. PRINT LISTS'; then, select the type of report to generate, and press the OK key.
USER DATA LIST	
CANCEL LIST	

5.6.2 Service Report

You can generate a report on detailed error information or settings made in service mode from among the following service reports:

#10 REPORT

1. System Data List

Indication : SERVICE DATA

Type : service mode #1 through #7, #13, start date output

2. Key History Report

Indication : KEY HISTORY REPORT

Type : 1800 key press made since most recent generation of history

3. Counter Report

Indication : COUNTER REPORT

Type : maintenance/parts counter output
changes made to the defaults of user data list and system data list;
system dump list
(for particulars of maintenance/parts counters, see 5.4.7 of Chapter 13)

4. Jam/Error Log Report

Indication : JAM/ERR LOG REPORT

Type : jam, error, alarm history

5. Specifications Report

Indication : PRINT SPEC REPORT

Type : TYPE settings, memory size, ROM indication, adjustment data

1. System Data List

Use it to check the service soft switch settings and service parameters.

```

2001 07/18 19:18                                     0 001

*****
*** SYSTEM DATA LIST ***
*****

SW01          -----          00010000
SW02          -----          10000000
SW03          -----          00000000
SW04          -----          10000000
SW05          -----          00000000
SW06          -----          10000000
SW07          -----          00000000
SW08          -----          00000000
SW09          -----          00000000
                -----          00000000
                -----          00000000
                -----          00000010
                -----          00000000

```

F13-506-01

4. Jam/Error Log Report
 Guide to a Jam History

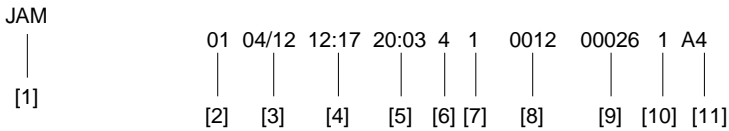

F13-506-02

- [1] jam history
- [2] sequence of jams (higher, more recent)
- [3] date of occurrence
- [4] time of occurrence
- [5] recovery time
- [6] approximate location (3: machine; 4: ADF; 5: finisher)
- [7] location block (0: machine; 1: ADF; 5: finisher)
- [8] jam code

The following is a list of codes and the types of jams corresponding to them:

Code	Jam type
0101	pickup assembly delay jam
0202	pickup assembly stationary jam
0105	delivery assembly delay jam
0206	delivery assembly stationary jam
1020	stationary jam
1121	front cover/left cover open jam
010a	No. 2 delivery slot delivery delay jam
0207	No. 2 delivery slot delivery stationary jam
020d	fixing assembly wrap jam

The following is a list of ADF codes and the types of jams corresponding to them:

Code	Jam type
0001	pickup jam
0003	read sensor delay jam
0004	read sensor stationary jam
0007	small sheet-to-sheet jam
0009	book over open error
000a	ADF cover open error
000b	residual original at start (registration sensor or read sensor)
0011	original pull-out
0012	jam at suspension
0013	jam at initialization
0016	other

The following is a list of finisher codes and the types of jams corresponding to them:

Code	Jam type
0021	delivery (finisher inlet) delay jam
0022	delivery (finisher inlet) stationary jam
0023	staple jam
0024	power-on jam
0025	stack delivery jam
0026	return jam
0027	stack retainer jam

[9] total counter reading (6 digits)

[10] paper source

1 : manual feed tray

2 : cassette 1

3 : cassette 2

4 : cassette 3

5 : cassette 4

[11] paper size

Guide to an Error History

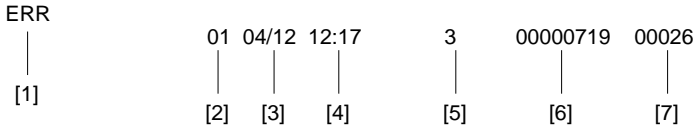

F13-506-03

- [1] error history
- [2] sequence of errors (higher, more recent)
- [3] date of occurrence
- [4] time of occurrence
- [5] approximate location (3: machine; 5: pickup assembly)
- [6] error code (in 8 digits, with rightmost 3 indicating the code on the LCD; for codes, see 6.2 of Chapter 13)
- [7] total counter (6 digits)

Guide to an Alarm History

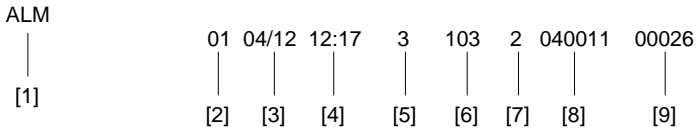

F13-506-04

- [1] alarm history
- [2] sequence of alarms (higher, the more recent)
- [3] date of occurrence
- [4] time of occurrence
- [5] approximate location (3: machine; 5: pickup assembly)
- [6] location
 - 103 : cassette 1
 - 104 : cassette 2
 - 105 : cassette 3
 - 106 : cassette 4
 - 113 : multifeder tray
- [7] alarm bell (for machine, '2' only)
- [8] alarm code (6 digits)

The following is a list of alarm codes and the type of alarms corresponding to them:

Code	Alarm type
040011	cassette 1 retry alarm
040012	cassette 2 retry alarm
040013	cassette 3 retry alarm
040014	cassette 4 retry alarm
040017	multifeder retry alarm

- [9] total counter (6 digits)

5. Specifications Report

The following items are used:

TYPE	indicates the country setting under '#5 TYPE' in service mode.
LBP SPEED	indicates the copying speed.
TOTAL MEMORY	indicates the total memory size.
MAIN	indicates the version of the ROM on the image processor PCB.
MAIN2	indicates the version of the CPU on the image processor PCB.
ECOUNT	indicates the version of the ROM on the DC controller PCB.
PDL*	indicates the version of the ROM on the printer board.
NIC*	indicates the version of the ROM on the network interface board.
FIN*	indicates the version of the ROM on the finisher controller PCB.
NCR*	indicates the version of the ROM on the card reader.
BODY No.	indicates the serial number of the machine.
TOTAL	
TTL1	indicates the reading of total 1.
LARGE	indicates the reading of large size.
COPY	
TTL1	indicates the number of copies.
LARGE	indicates the number of large-size prints in copier mode.
READ ADJ PRM	indicates the adjustment items and settings for the service mode item #6 SCANNER>7. CCD.

*Only if the respective accessory is installed.

6 Self Diagnosis

6.1 Outline

The machine is equipped with a function that checks its state; upon detection of a fault, it indicates its presence on the display using an error code.

The machine's error code is indicated as follows:

- EXXX

To obtain a history of error codes, make the following selections in service mode: #10
REPORT>JAM/ERR LOG REPORT.

6.2 Error Codes

The following are the possible error codes and causes of errors that can occur in the machine:

6.2.1 Error Codes Used for the Machine

E000	The main thermistor reading does not reach 40°C 14 sec after the fixing heater goes ON. (fixing low temperature error)
E001	The main thermistor reading reaches 220°C or higher. (fixing high temperature error)
E002	A start-up fault is detected under any of the following conditions of the main thermistor (start-up detection fault): after exceeding 40°C, it fails to reach 60°C within 10 sec. after exceeding 60°C, it fails to reach 80°C within 10 sec. after exceeding 80°C, it fails to reach 100°C within 10 sec. after exceeding 100°C, it fails to reach 120°C within 10 sec. after exceeding 120°C, it fails to reach 140°C within 10 sec. after exceeding 140°C, it fails to reach 160°C within 10 sec. after exceeding 160°C, it fails to reach 180°C within 10 sec. after exceeding 180°C, it fails to reach 195°C within 10 sec.
E003	After the end of the WAIT period, the main thermistor reading is 100°C or lower. In standby, the sub thermistor reading is 50°C or lower. (low temperature error in fixing temperature control)

E004

	<p>At time of initialization, the ZEROXI* signal of the power supply is not detected.</p> <p>During temperature control, the ZEROXI* signal does not arrive for 3 sec continuously.</p> <p>A short circuit is detected in the triac (ASIC; fixing temperature control drive circuit error).</p>
Possible cause	Fixing assembly is faulty. (The main thermistor has an open circuit. The sub thermistor has an open circuit. The fixing heater has an open circuit. The power supply PCB is faulty. The DC controller PCB is faulty.)
Note	To reset the error, execute the following in service mode, and turn off the and then on the power switch. #7 PRINTER>#4 PRINTER RESET>YES=(*)
Remedy	<p>1) Wiring Is the connection of the connector (CN8) on the power supply PCB and the connector (J103) on the DC controller PCB and the wiring to the fixing assembly normal? NO : Correct the connection and wiring.</p> <p>2) Fixing assembly Try replacing the fixing assembly. Is the fault corrected? YES : End.</p> <p>3) Power supply PCB, DC controller PCB Try repacking the power supply PCB. Is the fault corrected? YES : End. NO : Replace the DC controller PCB.</p> <p>4) Error With the power switch ON, clear E000 through E004; then, turn off and then on the power switch.</p>



If E000 through E004 is indicated, the RAM on the image processor will retain the error memory of the fixing assembly after the power switch has been turned off and then on. Execute the following in service mode, and turn off and then on the power switch to clear the memory: #7 PRINTER>#4 PRINTER RESET>YES=(*).

E010	<p>A specific revolution is not detected from the main motor rotation detection signal (MLOK*), causing the signal to go '1'. (main motor fault)</p>
Possible cause	The main motor (M101) is faulty. The controller PCB is faulty.
Remedy	<p>1) Connector Is the connection of the connector (J903) of the main motor and the connector (J06) on the DC controller PCB normal? NO : Correct the connection.</p> <p>2) Main motor (M101), DC controller PCB Try replacing the main motor. Is the fault corrected? YES : Replace the main motor. NO : Check the wiring; if normal, replace the DC controller PCB.</p>

E100	<p>When the scanner motor is started up, the BD input signal does not arrive within a specific period of time.</p> <p>When the scanner motor is started up, the motor rotation is too fast, and fails to reach a specific revolution within 20 sec at time of deceleration.</p> <p>While the scanner motor is rotating at a specific speed, the BD input signal cycle is not within a specific range ($\pm 2\%$) for an equivalent of 10 mm (print distance).</p> <p>While the scanner motor is rotating at a specific speed, the BD input signal cycle is not as indicated ($\pm 2\%$).</p> <p>During the WMUPR period after the power switch has been turned on or the front cover/left cover has been opened/closed, the drum unit is absent.</p>
Possible cause	The wiring is faulty (short circuit, open circuit). The laser scanner unit is faulty. The DC controller PCB is faulty. The drum unit is not installed.
Remedy	<p>1) Drum unit Is the drum unit installed in host machine? NO : Install the drum unit.</p> <p>2) Connection Is the connection of the connector (J908) on the BD detection PCB, connector (J907) of the laser unit, and connector (J102) on the DC controller PCB normal? NO : Correct the connection.</p> <p>3) Laser/scanner unit, DC controller PCB Try replacing the laser/scanner unit. Is the fault corrected? YES : End. NO : Replace the DC controller PCB.</p>

E719

	The communication between the card reader and the image processor PCB is disrupted.
Possible cause	The wiring is faulty (short circuit, open circuit). The card reader is faulty. The image processor PCB is faulty.
Note	Be sure to clear the error in service mode : #12 CLEAR>CARD.
Remedy	<p>1) Connector Is the connection and the wiring for the connector (J1131) of the card reader and the connector (J210) on the image processor PCB normal? NO : Correct the connection.</p> <p>2) Image processor PCB Try replacing the card reader. Is the fault corrected? YES : End. NO : Replace the image processor PCB.</p>



If E719 is indicated, the fault in communication is retained by the RAM on the image processor even when the power switch has been turned off and then on; be sure to execute #12 CLEAR>CARD in service mode before making corrections.

E805

After the heat discharge fan drive signal is generated, the fan lock detection signal does not arrive for a specific period of time.

Possible cause The fan wiring is faulty (short circuit, open circuit). The heat discharge fan (FM101) is faulty. The DC controller PCB is faulty.

Remedy

1) Foreign matter

Is there foreign matter that prevents the rotation of the fan?

YES : Remove the foreign matter.

2) Wiring, Connector

Is the connection and wiring of the connector (J951) of the heat discharge fan (FM101) and the connector (J106) on the DC controller PCB normal?

NO : Correct the wiring.

3) Heat discharge fan (FM101), DC controller PCB

Try replacing the heat discharge fan (FM101). Is the fault corrected?

YES : End.

NO : Replace the DC controller PCB.

6.2.2 Finisher Error Codes

<p>E500</p> <p>Possible cause</p> <p>Remedy</p>	<p>An error has occurred in the communication between the machine and the finisher twice continuously.</p> <p>The harness to the finisher is faulty (disconnected connector, open circuit). The finisher controller PCB or the DC controller PCB is faulty.</p> <p>1) Power switch Try turning off and then on the power switch. Is the fault corrected? YES : End.</p> <p>2) Wiring Is the wiring from the finisher controller PCB to the DC controller PCB normal? NO : Corrected the wiring.</p> <p>3) Finisher controller PCB, DC controller PCB Try replacing the finisher controller PCB. Is the fault corrected? YES : End. NO : Replace the DC controller PCB.</p>
<p>E514</p> <p>Possible cause</p> <p>Remedy</p>	<p>The stack delivery belt does not reach home position when the stack handling motor (M2) is driven for a specific time (CW; if the same condition occurs during stack delivery, a jam will be identified).</p> <p>The stack handling motor (M2) is faulty. The stack delivery home position sensor (S8) is faulty. The connector is disconnected or has an operation circuit. The stack handling motor relay harness is faulty. The stack delivery belt is faulty. The finisher controller PCB is faulty.</p> <p>1) Stack handling motor drive belt Is the tension of the drive belt appropriate? NO : Loosen the screw on the tension to correct the tension.</p> <p>2) Wiring Is the wiring between the finisher controller PCB and the harness handling motor (M2) normal? NO : Correct the wiring.</p> <p>3) Sensor flag Are the sensor flag spring and the flag normal? NO : Correct the spring or the flag.</p>

- 4) **Stack delivery lever home position sensor (S8)**
Check the stack delivery lever home position sensor (S8). Is the sensor normal?
 NO : Replace the sensor.
- 5) **Stack handling motor (M2), Finisher controller PCB**
Try replacing the stack handling motor (M2). Is the fault corrected?
 YES : End.
 NO : Replace the finisher controller PCB.

E530

The rear aligning plate does not reach home position when the rear alignment motor (M4) has been driven for a specific time.
 The rear aligning plate does not reach home position when the rear alignment motor (M4) has been driven for a specific time.

Possible cause

The rear alignment motor (M4) is faulty. The rear aligning plate home position sensor (S7) is faulty. The sensor connector is disconnected or has an open circuit. The rear alignment motor relay harness is faulty. The rear aligning plate is subjected to an abnormal load. The finisher controller PCB is faulty.

Remedy

- 1) **Rear aligning plate home position sensor (S7)**
Check the rear aligning plate home position sensor (S7). Is the sensor normal?
 NO : Replace the sensor.
- 2) **Wiring**
List the wiring between the finisher controller PCB and the rear alignment motor (M4).
 NO : Correct the wiring.
- 3) **Rear aligning plate**
Is the rack riding cover the collar of the roll?
 YES : Correct it.
- 4) **Rear alignment motor (M4), Finisher controller PCB**
Try replacing the rear alignment motor (M4). Is the fault corrected?
 YES : End.
 NO : Replace the finisher controller PCB.

<p>E531</p>	<p>The stapler does not leave the stapling home position sensor (S13) within 0.5 sec after the stapler motor (M6) is rotated CW.</p> <p>The stapler does to return to the home position sensor (S13) within 0.5 sec after the stapler motor (M6) is driven CW and, in addition, it does not return to the sensor within 0.5 sec after the motor is driven CCW thereafter.</p> <p>Possible cause The stapler motor (M6) is faulty. The stapler home position sensor (SW1) is faulty. The stapler harness is faulty. The finisher controller PCB is faulty.</p> <p>Remedy</p> <ol style="list-style-type: none"> 1) Wiring It the wiring between the stapler unit and the finisher controller PCB normal? NO : Correct the wiring. 2) Stapler unit, Finisher controller PCB Try replacing the stapler unit. Is the fault corrected? YES : End. NO : Replace the finisher controller PCB.
<p>E537</p>	<p>The front aligning plate does not reach home position when the front aligning motor (M3) is driven for a specific time.</p> <p>The front aligning plate does not leave home position when the front alignment motor (M3) is driven for a specific time.</p> <p>Possible cause The front alignment motor (M3) is faulty. The front aligning plate home position sensor (S6) is faulty. The sensor connector is disconnected or has an open circuit. The front alignment motor relay harness if faulty. The front aligning plate is subjected to an abnormal load. The finisher controller PCB is faulty.</p> <p>Remedy</p> <ol style="list-style-type: none"> 1) Front aligning plate home position sensor (S6) Check the front aligning plate home position sensor (S6). Is the sensor normal? NO : Replace the sensor. 2) wiring Is the wiring between the finisher controller PCB and the front alignment motor (M3) normal? NO : Correct the wiring. 3) Front aligning plate Is the rack riding over the collar of the roll? YES : Correct it.

4) Front alignment motor (M3), Finisher controller PCB
Try replacing the front alignment motor (M3). Is the problem corrected?

YES : End.

NO : Replace the finisher controller PCB.

E551

The delivery fan rotation signal (FNALCOK) does not arrive within 1 sec when the heat discharge fan drive signal (FANON) is sent.

Possible cause The heat discharge fan (FM1) is faulty. The heat discharge fan relay harness is faulty. The heat discharge fan is subjected to an abnormal load. The finisher controller PCB is faulty.

Remedy

1) Wiring

Is the wiring between the heat discharge fan and the finisher controller PCB normal?

NO : Correct the wiring.

2) Heat discharge fan (FM1), Finisher controller PCB

Try replacing the heat discharge fan (FM1). Is the fault corrected?

YES : End.

NO : Replace the finisher controller PCB.

E577

	<p>The return roller does not reach home position when the delivery motor (M1) is driven for a specific time. (If the same condition is detected while alignment takes place in the direction of feed, a jam will be identified.)</p>
Possible cause	<p>The delivery motor (M1) on the finisher controller PCB is faulty. The return roller home position sensor (S3) is faulty. The connector is disconnected or has an open circuit. The delivery motor relay harness is faulty. The return roller is faulty. The finisher controller PCB is faulty.</p>
Remedy	<p>1) Delivery motor (drive mechanism) Is the return roller rotation when the motor is rotating CCW? NO : Correcting the drive mechanism. Is the return roller displaced? NO : Correct the return roller spring. Is the tension of the delivery motor drive belt appropriate? NO : Loosen the screw, and correct the tension.</p> <p>2) Return roller home position sensor (S3) Check the return roller home position sensor (S3). Is the sensor normal? NO : Replace the sensor.</p> <p>3) Delivery motor (M1), Finisher controller PCB Try replacing the delivery motor (M1). Is the fault corrected? YES : End. NO : Replace the finisher controller PCB.</p>

E580

Possible cause	<p>The stack tray upper limit sensor (S1) goes ON while the stack tray up/down motor (M5) is in operation.</p> <p>The clock signal of the stack tray up/down clock sensor (S9) is not detected 15 times or more within 0.8 sec while the stack tray up/down motor (M5) is in operation.</p> <p>It does not reach the stack tray paper height sensor (S10) 2 sec after the stack tray up/down motor (M5) rotates for ascent.</p> <p>It does not leave the stack tray power height sensor (S10) 2 sec after the stack tray up/down motor (M5) starts to rotate for descent.</p> <p>The stack tray up/down motor (M5) is faulty. The stack tray paper height sensor (S10) is faulty. The sensor connector is disconnected or has an open circuit. The stack tray up/down clock sensor (SW9) is faulty. The sensor connector is disconnected or has an open circuit. The stack tray up/down motor is subjected to an abnormal load. The finisher controller PCB is faulty.</p>
----------------	--

Remedy

- 1) **Stack tray up/down motor (encoder)**
Try turning the encoder of the stack tray up/down motor by hand. Does it rotate smoothly?
NO : Correct the mechanical mechanism.
- 2) **Wiring**
Is the wiring between the finisher controller PCB and the stack tray up/down motor (M5) normal?
NO : Correct the wiring.
- 3) **Tray phase**
Is the left/right phase of the stack tray normal?
NO : Correct the phase.
- 4) **Stack tray up/down lock sensor (S9)**
Check the stack tray up/down clock sensor (S9). Is the sensor normal?
NO : Replace the sensor.
- 5) **Stack tray paper height sensor (S10)**
Check the stack tray paper height sensor (S10). Is the sensor normal?
NO : Replace the sensor.
- 6) **Stack tray paper limited sensor (S1), Stack tray lower limit sensor (S12)**
Check the stack tray upper limit sensor (S1) and the stack tray lower limit sensor (S12). Are the sensors normal?
NO : Replace the sensors.
- 7) **Stack tray up/down motor (M5), Finisher controller PCB**
Try replacing the stack tray up/down motor (M5). Is the fault corrected?
YES : End.
NO : Replace the finisher controller PCB.

E585

The stack retaining lever does not reach home position when the stack handling motor (M2) has been driven for a specific time (at the start of motor CCW rotation). (If the same condition is detected during stack delivery, a jam will be identified.)

Possible cause The stack handling motor (M2) is faulty. The stack delivery lever home position sensor (S8) is faulty. The sensor connector is disconnected or has an open circuit. The stack handling motor relay harness is faulty. The stack retaining lever is faulty. The finisher controller PCB is faulty.

Remedy

- 1) **Stack holding motor drive belt.**
Is the tension of the drive belt appropriate?
 NO : Loosen the screw, and correct the tension.
- 2) **Stack handling motor (drive mechanism)**
Is the return roller rotating while the motor is rotating CCW?
 NO : Correct that drive mechanism.
- 3) **Wiring**
Is the wiring between the finisher controller PCB and the stack handling motor (M2) normal?
 NO : Correct the wiring.
- 4) **Stack retaining lever home position sensor (S4)**
Check the stack retaining lever home position sensor (S4). Is the sensor normal?
 NO : Replace the sensor.
- 5) **Stack handling motor (M2), Finisher controller PCB**
Try replacing the stack handling motor (M2). Is the fault corrected?
 YES : End.
 NO : Replace the finisher controller PCB.

CHAPTER 14

VERSION UP

1 Upgrading

1.1 Outline

The machine or its accessory is upgraded by downloading firmware from a PC or by replacing the ROM DIMM.

The firmware that may be upgraded is either of the following 2 types:

- System software (machine; ROM DIMM on image processor PCB)
- Finisher-L1 (accessory; ROM DIMM on finisher controller PCB)

Downloading of the system software is done by way of the USB port of the image processor PCB.

The ROM DIMM is made available as a service part, and upgrading may take place by replacing the ROM DIMM.

Downloading of the Finisher-L1 is done by connecting a PC to the finisher controller PCB by way of downloader PCB.

The ROM is built into the CPU, which is directly soldered to the finisher controller, and cannot be replaced in the field.

Upgrading by replacing the ROM DIMM

Upgrading by downloading

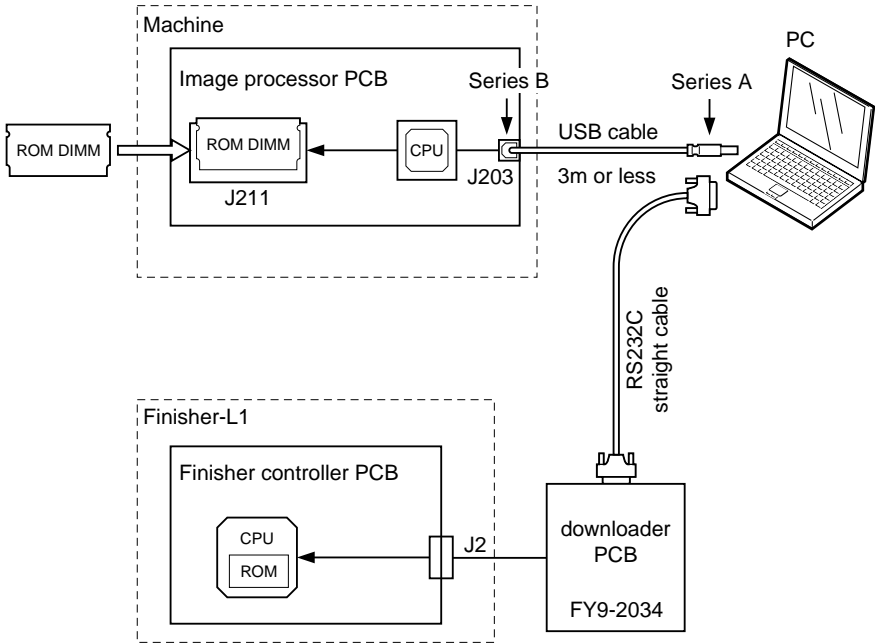

F14-101-01

2 Upgrading by Downloading

2.1 Before Starting the Work

Prepare the following:

- PC to which the Service Support Tool (version 1.31E or later) has been installed.
Downloading will be by way of a USB port; be sure that its OS supports SUB (Windows 98/98SE/2000).
You cannot use Windows 95 or Windows NT, as they do not support USB.
Firmware for downloading
- The firmware for the machine will be offered in compressed form (self-decompressing).
USB cable
- You will need a USB cable for downloading the system software.
downloader PCB (FY9-2034)
- You will need the downloader PCB for downloading for the Finisher-L1.

2.2 Installing the USB Driver (only if Windows 98 or Windows 98SE)

To connect the machine to a PC, you must install a USB driver to the PC. (This is required when you first connect the machine to a PC running on Windows 98 or 98SE. Once done, it need not be done for a second time. You may also skip it if Windows 2000 is used.)

- 1) Connect the PC to which the Service Support Tool (Ver. 1.31E or later) has been installed to the machine using a USB cable.
- 2) Turn on the PC and the machine in sequence.
- 3) When [Add New Hardware Wizard] has started up, click 'Next'.

- 4) Select 'Search for the best driver for your device. (Recommended)', and click 'Next'.



F14-202-01

- 5) Select 'Specify a location', and click 'Browse'; then, select 'C:\ProgramFiles\ServiceSupportTool\inf\usbprint', and click 'Next'.



F14-202-02

- 6) Click 'Next'.
- 7) When the screen indicates the end of installation, click 'Finish'.
- 8) Click 'Yes' to re-start the PC.



F14-202-03

2.3 Installing the Firmware

To start downloading, you need to install the firmware in question to the Service Support Tool; the individual pieces of firmware will be installed under the following names:

Firmware Built into the Machine

Model : iR1600

Unit name

Image processor PCB : System

Finisher-L1

Model name : Fin-L1

Unit name

Finisher controller PCB : CPU

The same firmware is used in common for the iR1600 and the iR2000. Be sure to select the iR1600 when you are asked to select a model for the Service Support Tool for either of these models.

To install the system software, for example, go through the following:

- 1) Decompress the firmware, and store it in the NewROM folder.
The firmware is offered in self-decompression form. Click the file (obtained using Explorer) so that it will decompress on its own.
Its destination will be the following folder, which is created when the Service Support Tool is installed using default settings:
C:\ServTool\NewROM
- 2) Start up the Service Support Tool.
- 3) Click 'To Next' under [Controlling Data].
- 4) Click 'Registering Firmware'.

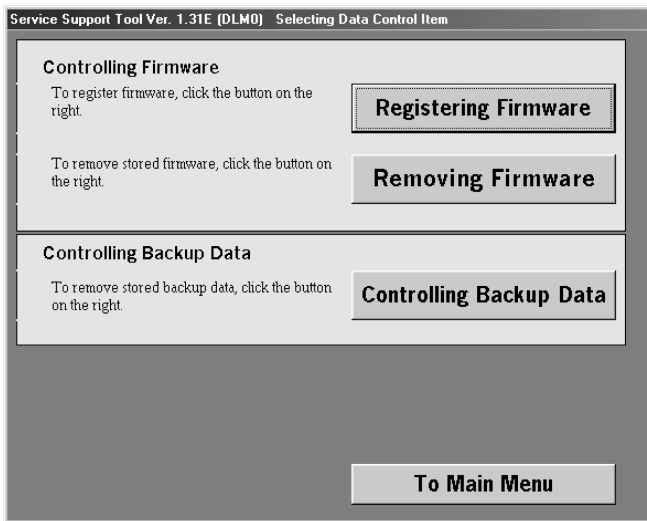

F14-203-01

- 5) Click 'Register from NewROM folder'.

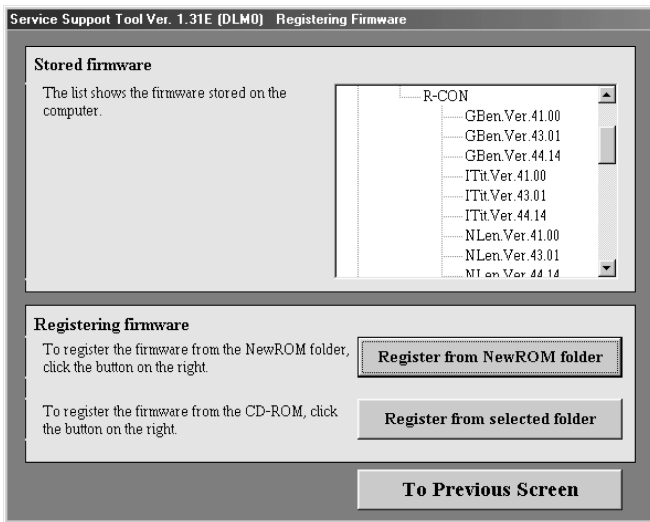

F14-203-02

- 6) Check to see that the firmware in question has been added to the list of firmware.

2.4 Downloading the System Software

a. Before Mounting

If you are upgrading the machine (i.e., replacing the ROM DIMM or downloading from a PC), you will have to execute 'ALL CLEAR' after mounting. Be sure to print out the stored data before you start installation or upgrading.

• Printing Out the Stored Data

Generating a Counter Report

In service mode, make the following selections: #10 REPORT>COUNTER REPORT.

The Counter Report provides the following contents:

- 1) various counter data
- 2) data produced as the result of changes made to factory settings (user data/service data)
- 3) system dump list (not used)

b. Making Connections

To download using a USB connection, go through the following:

- 1) Turn off the machine.
- 2) Remove the rear cover, and connect the USB connector (J203) on the image processor PCB and the PC using a USB cable. If a network interface board is mounted, disconnect the USB cable from the board.

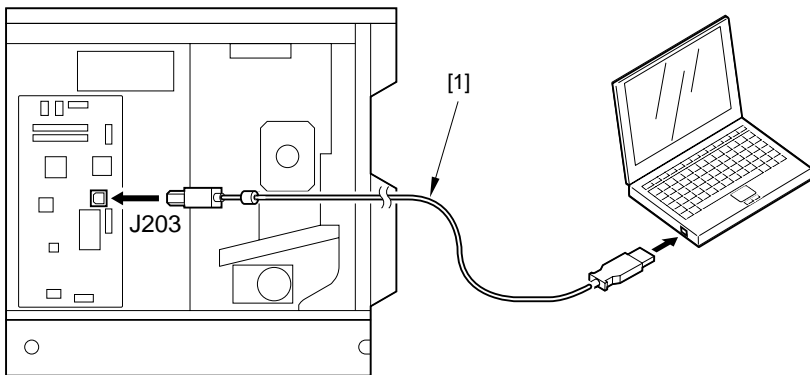

F14-204-01

- 3) Turn on the PC, and start up the Service Support Tool.
- 4) Turn on the machine.

c. Downloading

- 1) Turn on the power switch so that [Add New Hardware Wizard] appears; click 'Cancel'.



F14-204-02

- 2) Click 'To Next' under [Downloading/Uploading].

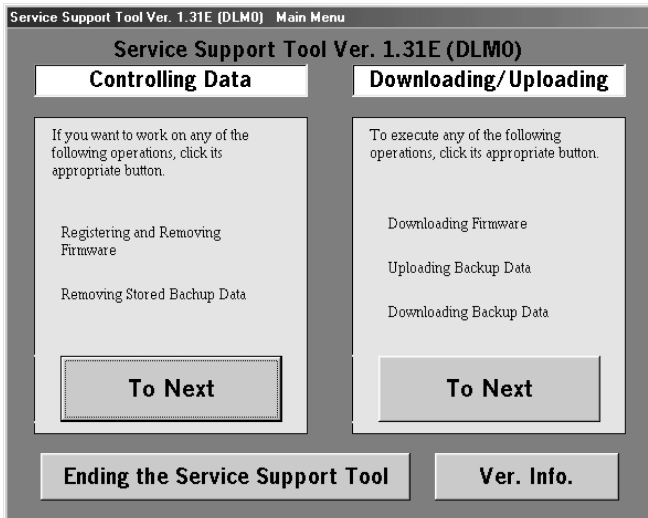

F14-204-03

- 3) Press the User Mode key and the # key in the control panel to start service mode.
- 4) Using the cursor key ◀/▶, select '#11 DOWNLOAD'.
- 5) Click 'OK' so that the machine will be in download standby mode (indicating 'DOWNLOAD CONNECTED').
- 6) Select 'iR1600 SYSTEM' on the PC's screen, and click 'Connect'.

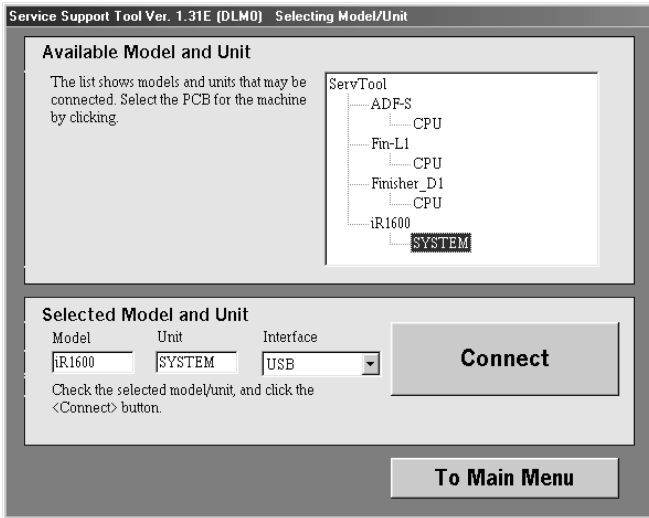

F14-204-04

- 7) Click 'OK' to start the connection.

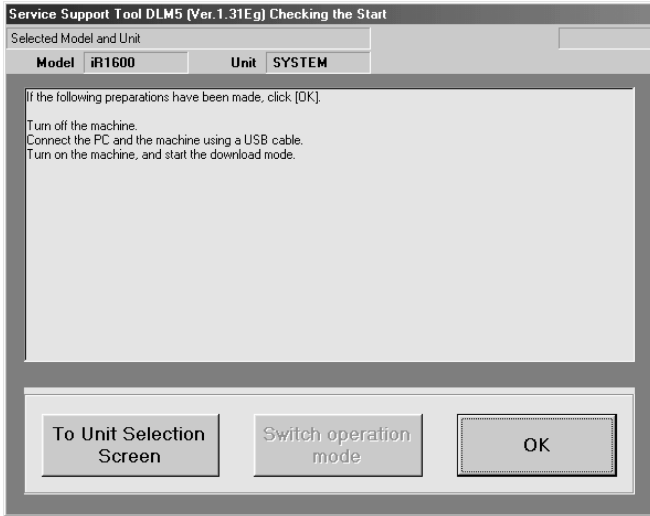

F14-204-05

- 8) When the connection is made, the following screen will appear; click 'OK'.

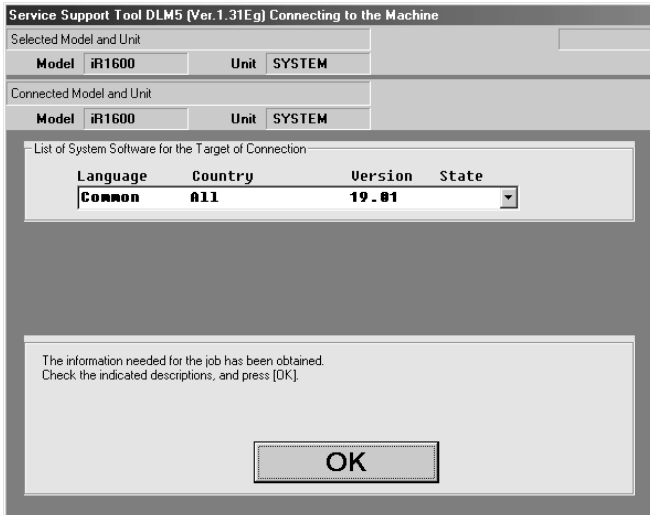

F14-204-06

9) Click 'System Software Download'.

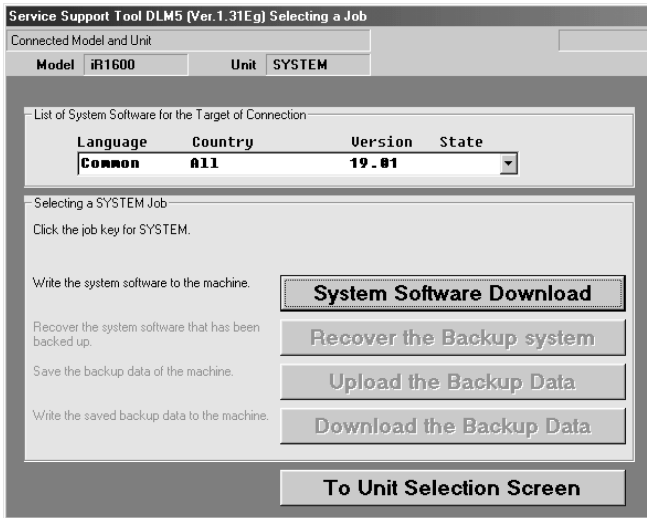

F14-204-07

10) Select the system software to download from the list, and click 'Start' so that downloading will start.

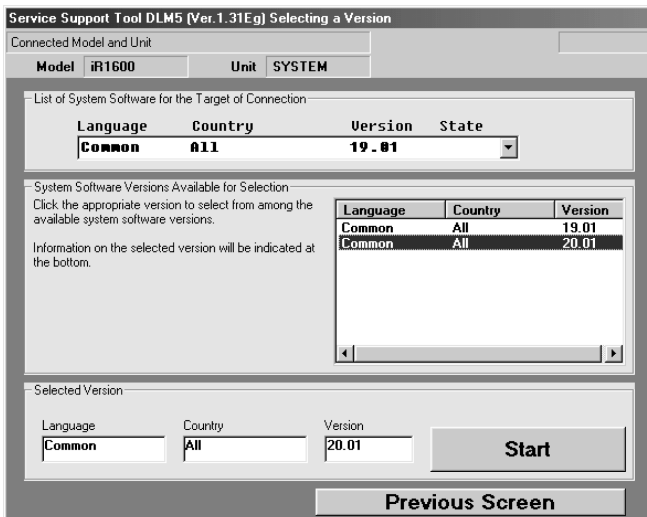

F14-204-08

11) See that some LEDs of the machine remain ON while downloading is taking place.



Do not turn off the power or disconnect the cable while downloading from the PC is taking place. Otherwise, the ROM DIMM will no longer be usable, requiring replacement.

- 12) See that the machine re-starts automatically at the end of downloading. When [Add New Hardware Wizard] has started up, click 'Cancel'.
13) A screen appears; check that the result is 'OK'.



Do not turn off the power even when the transfer of firmware has ended from the PC to the machine, as the machine is likely to be deleting/writing ROM DIMM programs. If done at the wrong timing, the programs will be incomplete, preventing the machine from starting up.

c. After Finishing Downloading

- 1) Turn off the power switch of the machine.
- 2) Turn off the PC.
- 3) Disconnect the USB cable from the PC and the machine.
- 4) (If a network interface board is mounted, connect the USB cable to the network interface able.) Mount the rear cover.
- 5) Turn on the power switch of the machine.
- 6) Press the User Mode key and the # key in the control panel to start service mode.
- 7) Using the cursor key ◀/▶, select '#13 ROM', and click 'OK'.
- 8) Using the cursor key ◀/▶, check the version indicated under 'MAIN'.
- 9) Execute the following in service mode: #12 CLEAR>ALL.
- 10) Enter the following in service mode: #5 TYPE.
- 11) Be sure to ensure that you set the country type to suit the communication standard used in your country/region using the cursor key.
- 12) Press the OK key so that the entered type settings will be stored.
- 13) Press clear key to return the copying mode.
- 14) Store the data that has been cleared and data which has been returned to factory settings.



Executing 'ALL CLEAR' will not clear the various counter data and the data stored under #6 SCANNER>7 CCD in service mode; i.e., you need not store them newly.

2.5 Downloading for the Finisher-L1

2.5.1 Outline

To upgrade the Finisher-L1 (accessory) by upgrading the ROM on the controller PCB, use a downloader PCB (FY9-2034).

Names and Functions

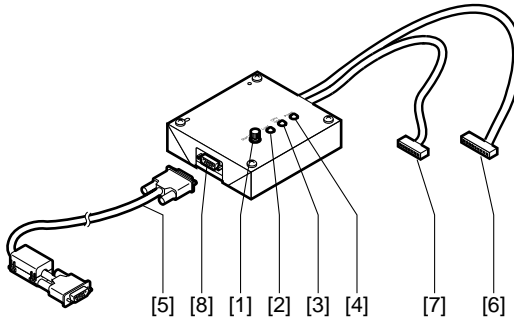

F14-205-01

Component names and functions

Ref.	Name	Description
[1]	Start/Stop button	Press it to start/end downloading.
[2]	Load LED	Remains ON while downloading is possible.
[3]	CPU type indicator LED	Not used.
[4]	Power LED	Remains ON when the downloader PCB is supplied with power by the accessory.
[5]	RS-232C cable (straight, full-wire; 9-pin)	Used to connect the downloader PC and a PC. Be sure to connect it so that its ferrite core is on the PC side.
[6]	Cable A (9-pin; about 70 cm long)	Not used in the machine.
[7]	Cable B (7-pin; about 50 cm long)	Used to connect the downloader PCB and the controller PCB of the accessory.
[8]	RS-232C connector	Used to connect the RS-232C cable to the downloader PCB.

T14-205-01

2.5.2 Downloading

a. Connecting to the Finisher

- 1) Turn off the power switch of the machine.
- 2) Remove the left front cover of the machine and the front cover of the finisher.
- 3) Connect the 7-pin connector [2] of the cable B [1] to the connector J2 [3] of the finisher controller PCB.

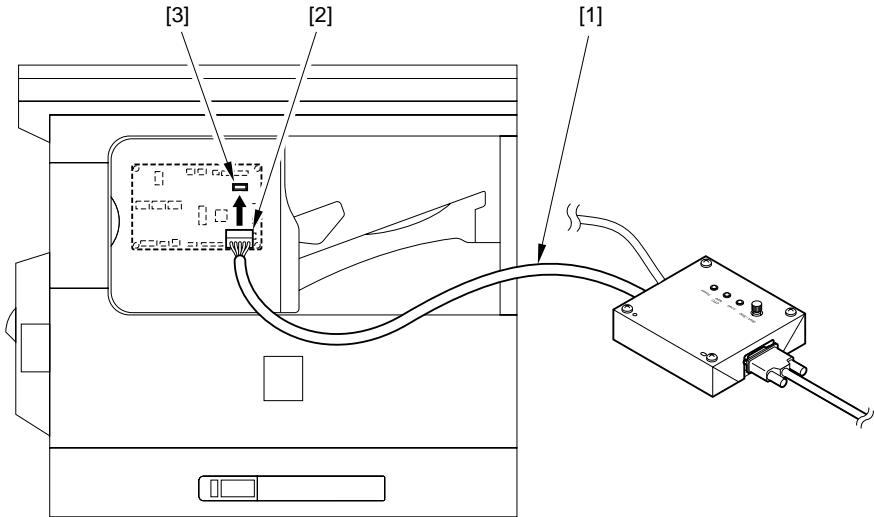

F14-205-02

- 4) Connect the RS-232C cable to the downloader PCB and the RS-232C connector of the PC. At this time, be sure that the ferrite core of the cable is on the PC side.
- 5) Turn on the PC and the machine in sequence.
- 6) When [Add New Hardware Wizard] has started up, click 'Cancel'.
- 7) Press the User Mode key and then the # key in the control panel to start service mode.
- 8) Using the cursor key ◀/▶, select '#11 DOWNLOAD'.
- 9) Click 'OK' so that the machine will be in download standby mode (indicating 'DOWNLOAD CONNECTED').

b. Downloading for the Finisher

- 1) Start up the Service Support Tool.
- 2) Click 'Next' under [Downloading/Uploading].

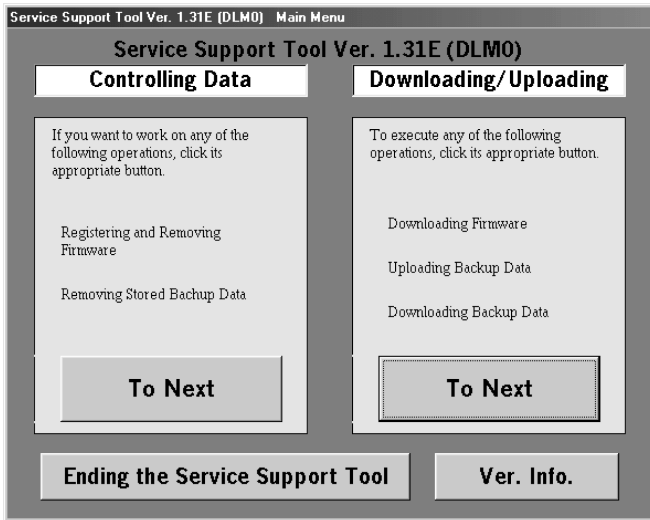

F14-205-03

- 3) Shift the 'Start/Stop' button on the download PCB to ON position so that the download indicator LED goes ON.
- 4) Select 'CPU' under 'Fin-L1' to highlight, and click 'Connect'.

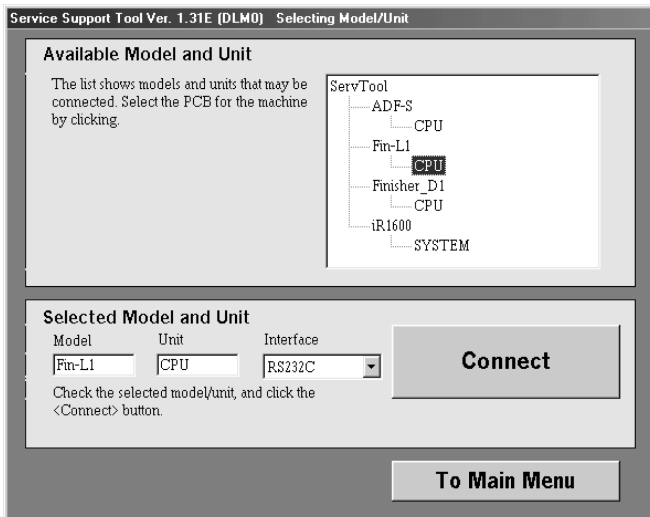

F14-205-04

- 5) Follow the instructions on the screen to prepare for downloading. Check that the download indicator LED is ON, and click 'OK' to move to the next screen.

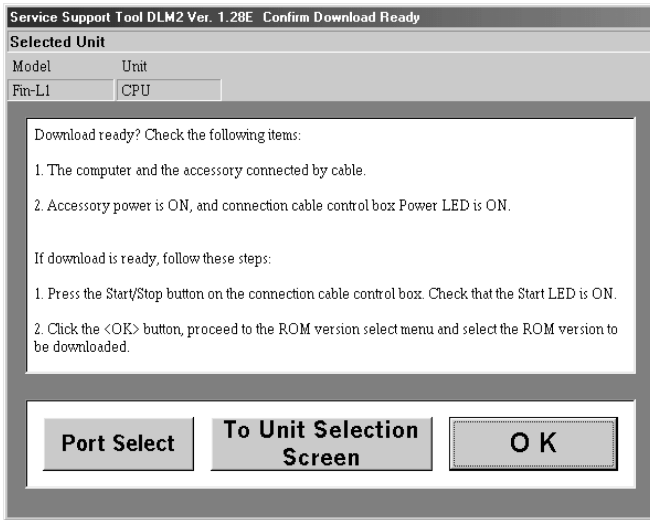

F14-205-05

- 6) Click the ROM version to download.

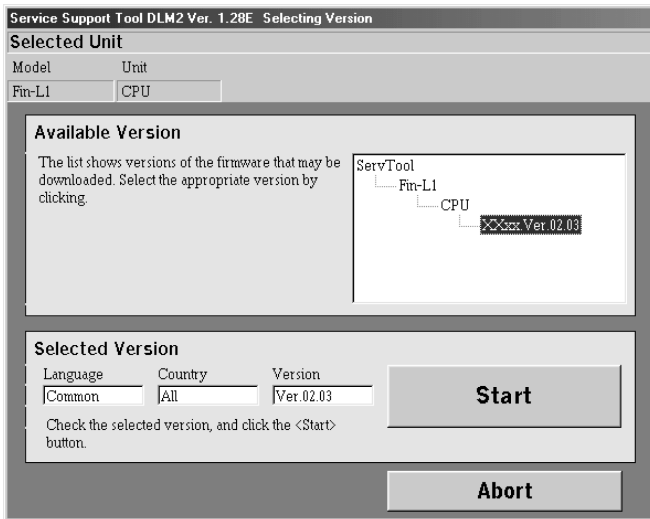

F14-205-06

- 7) Click 'Start' so that the PC will start downloading programs through the downloader PCB.
- 8) When downloading ends, click 'OK'.

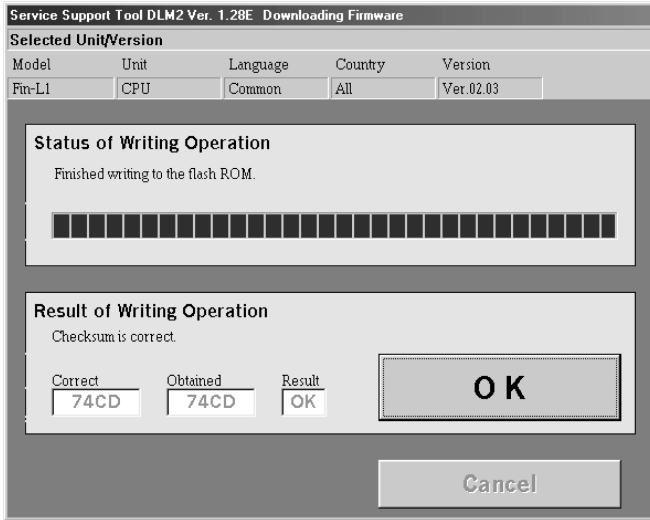

F14-205-07

9) Go through the instructions on the screen to end the work.

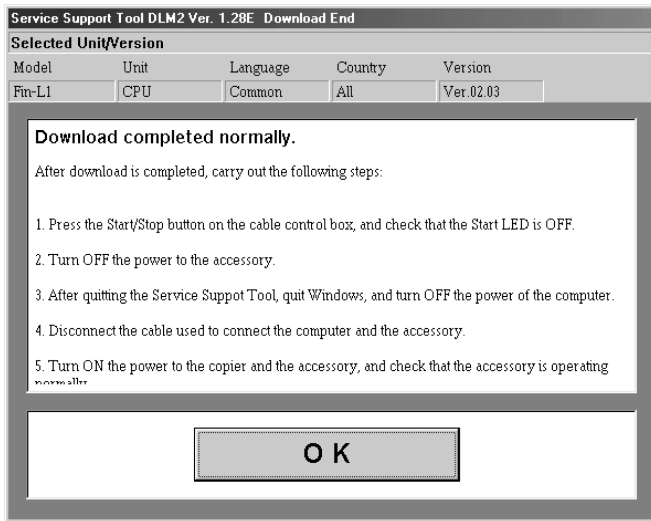

F14-205-08

c. Making Checks After Downloading

- 1) Press the 'Start/Stop' button on the downloader PCB so that the download indicator LED goes OFF.
- 2) Turn off the power switch of the machine.
- 3) Disconnect the cable B (7-pin connector) from the connector J2 of the finisher controller PCB.
- 4) Mount the front cover of the finisher and the left front cover of the machine.
- 5) Turn on the power switch of the machine.
- 6) Press the Additional function key and the ID (#) key in the control panel to start service mode.
- 7) Using the cursor ◀ / ▶,select '#13 ROM'.
- 8) Using the cursor ◀ / ▶,check the version indicated under [FIN].

APPENDIX

A General Timing Chart

Book copy, A4 paper, Machine cassette, 2 Prints

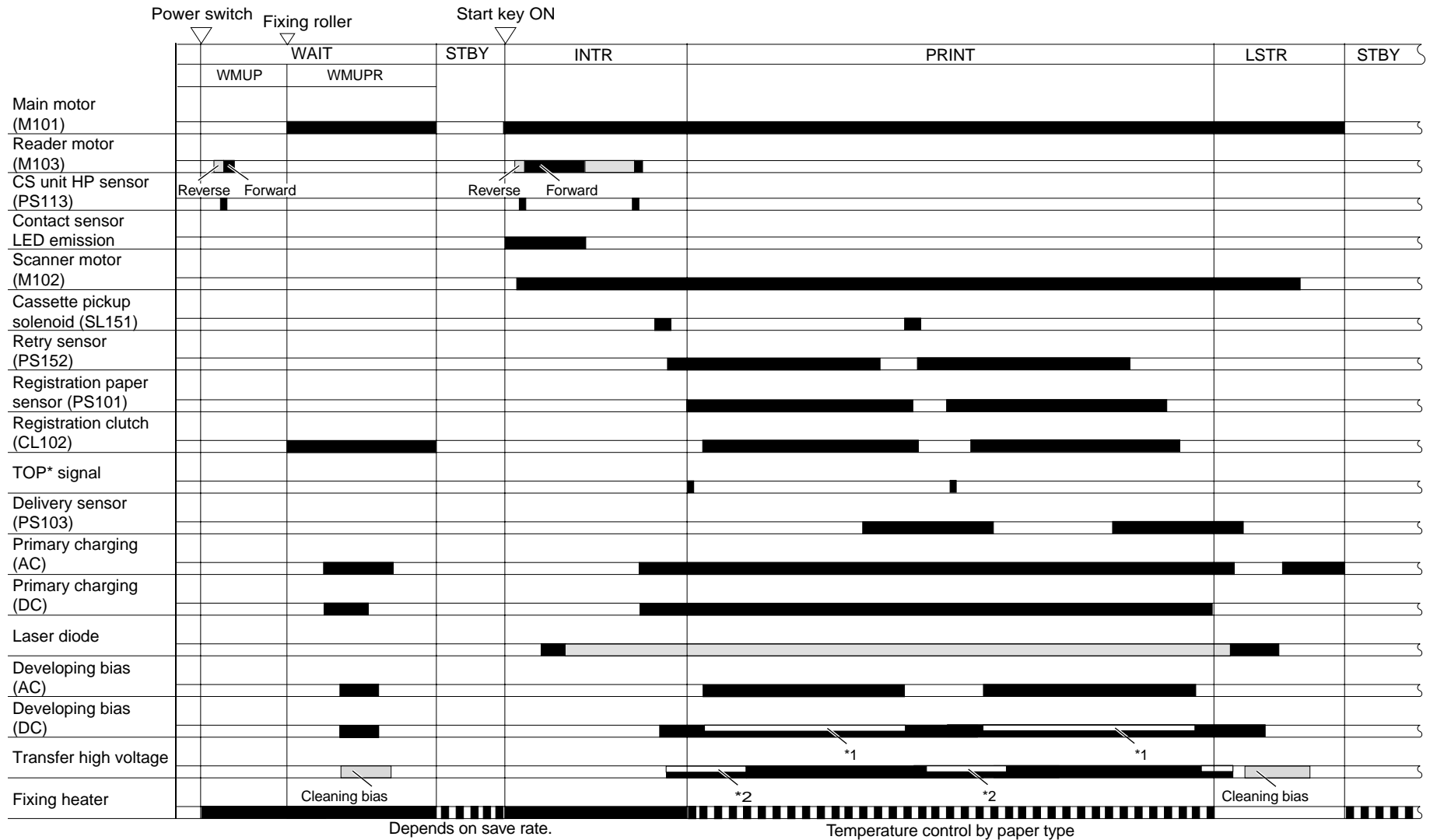

*1 : varies depending on the temperature setting. If PDL output, the copying is constant.
 *2 : ATVC control.

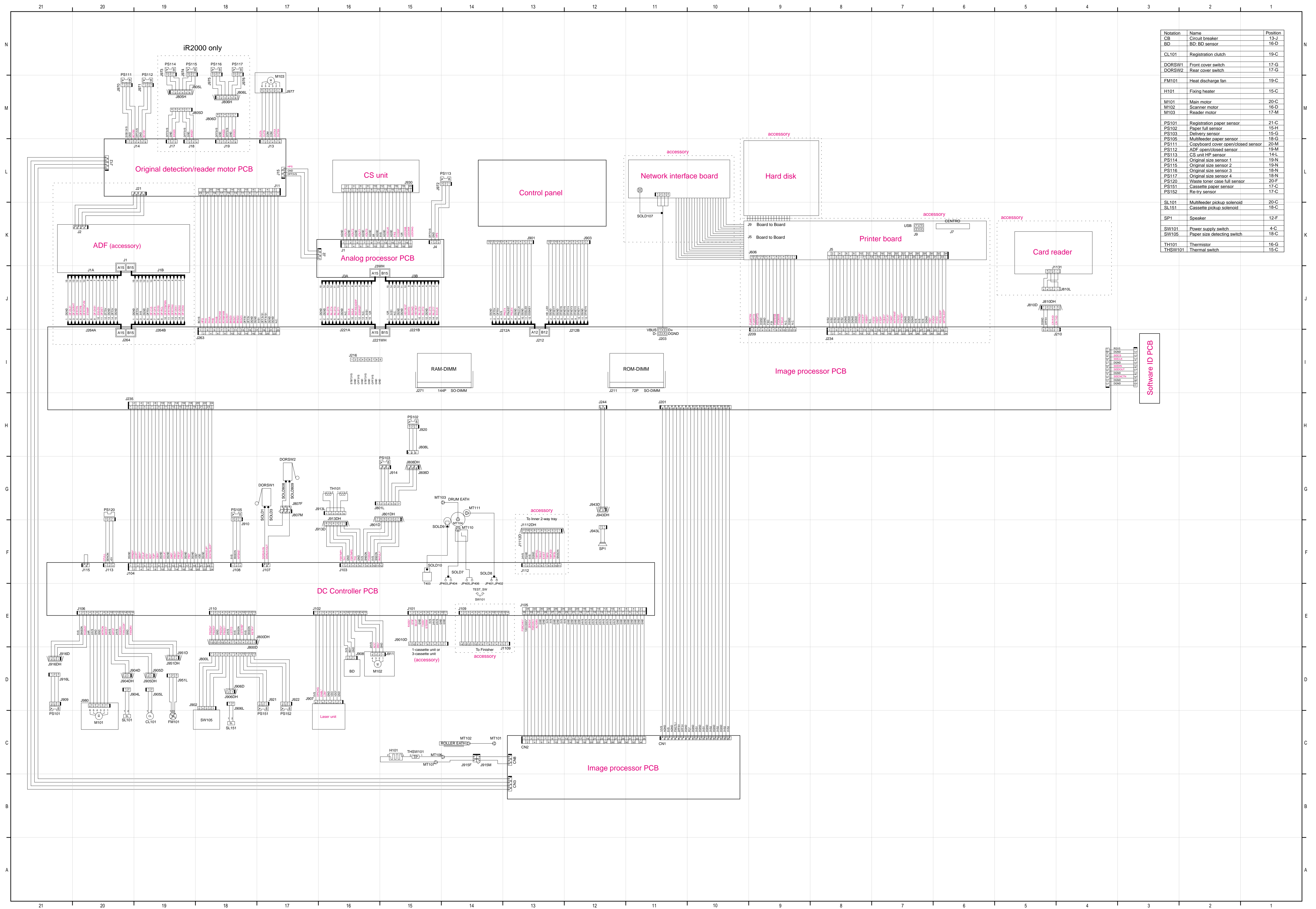

C 1-cassette unit

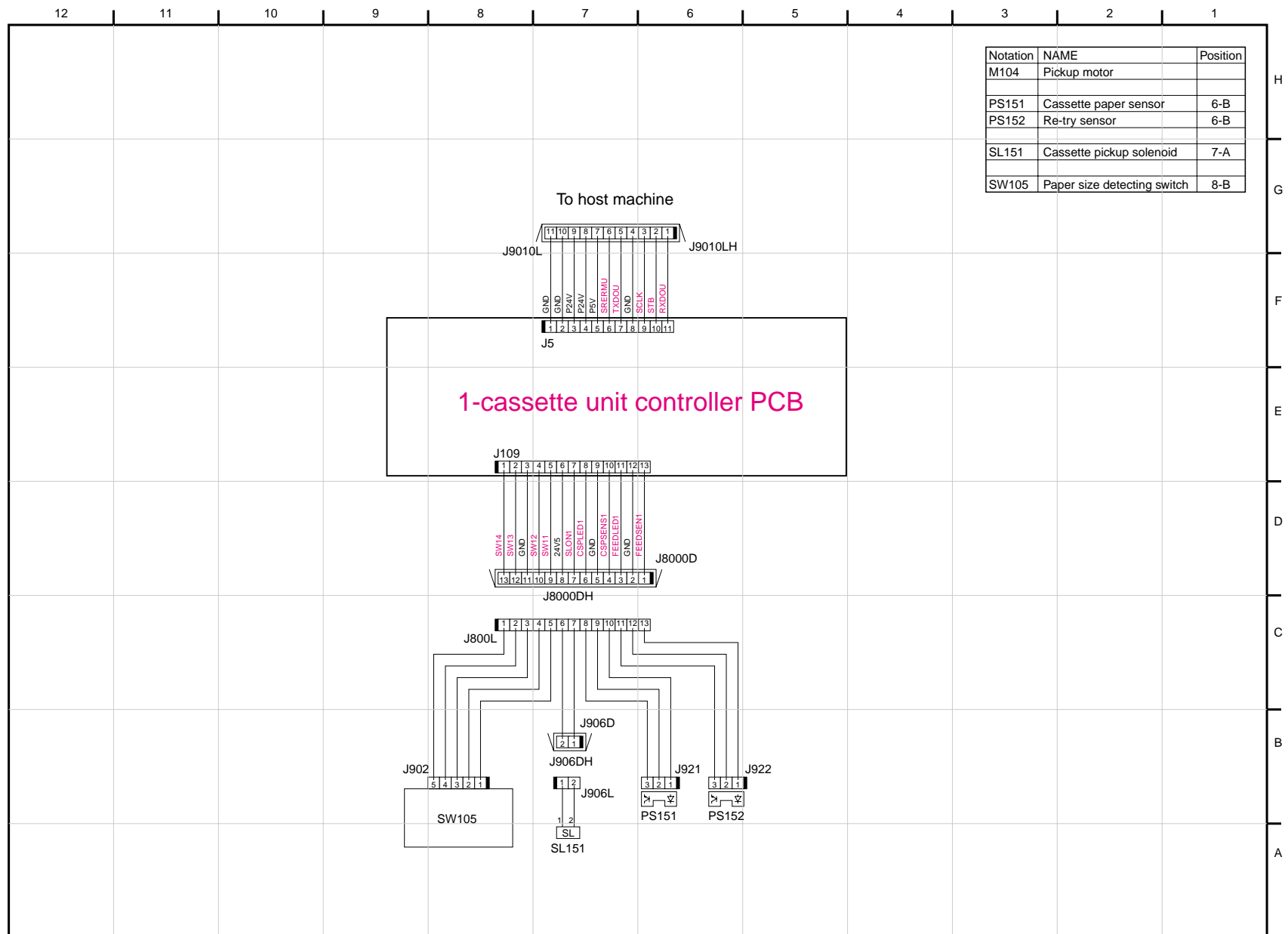

D 2/3-cassette unit

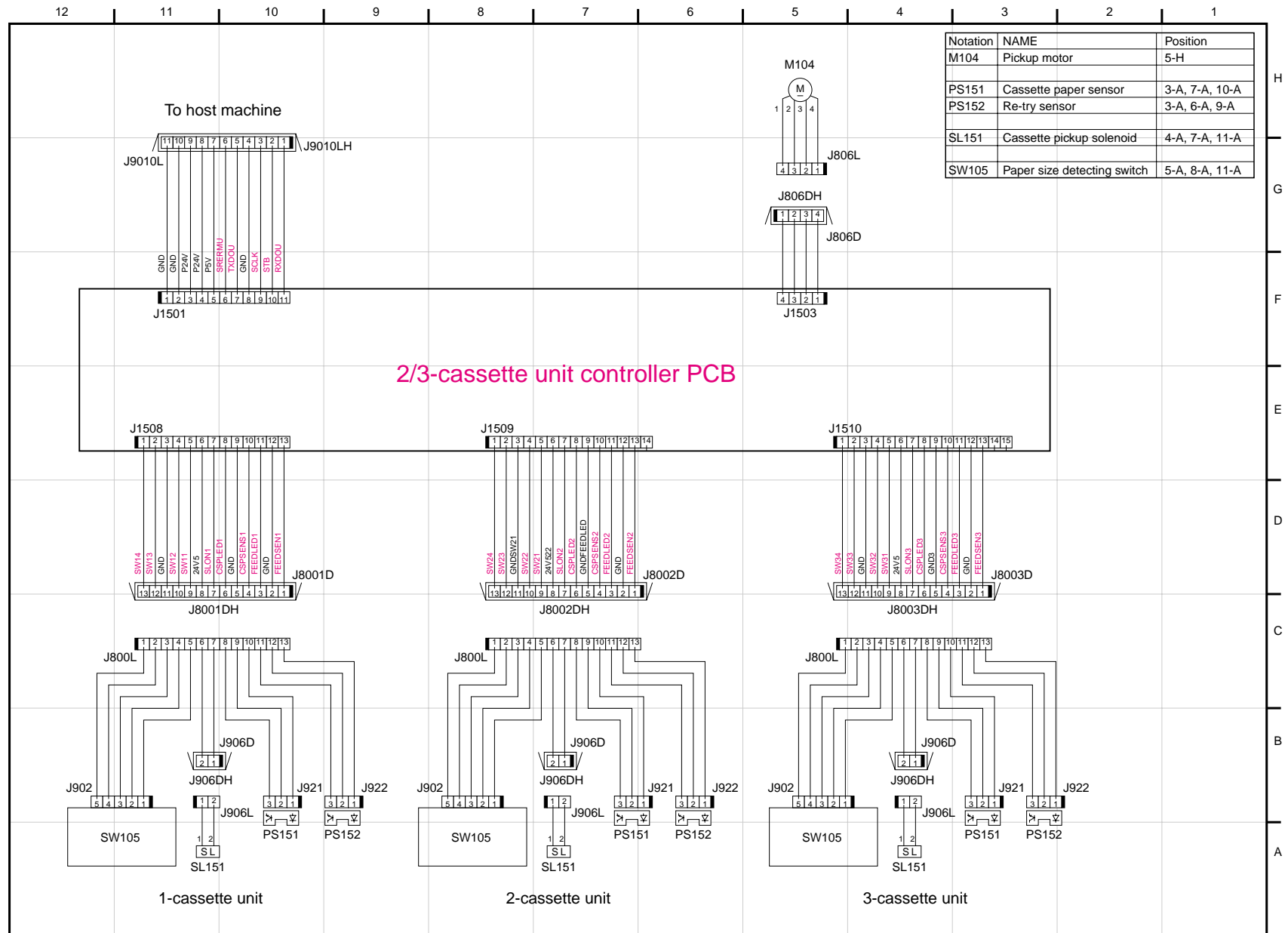

E Inner 2-way tray

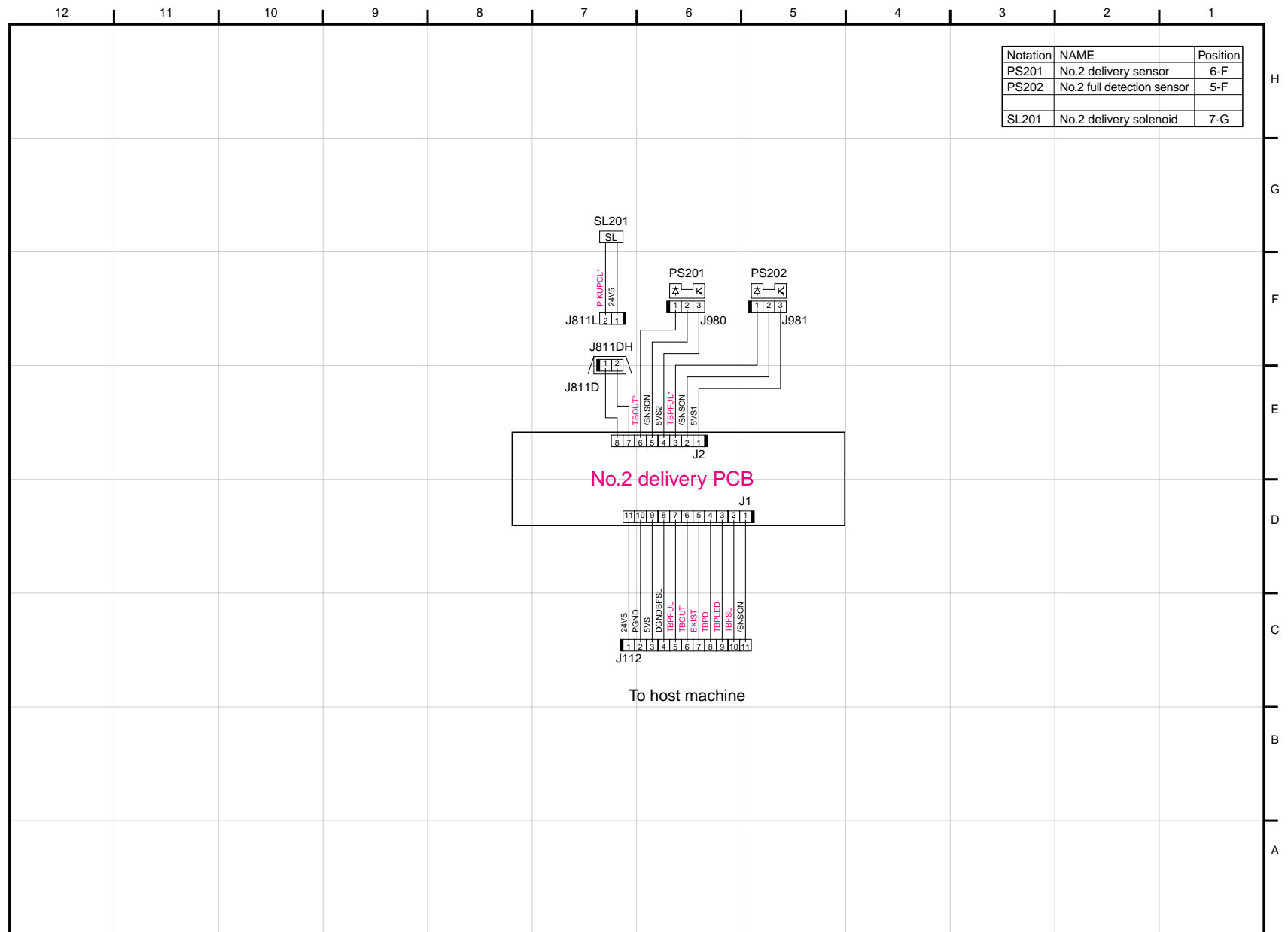

F Special Tools

In addition to the standard tools set, you will need the following special tools when servicing the machine in the field:

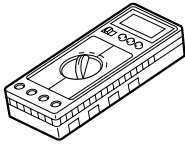
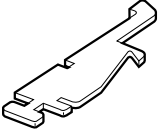
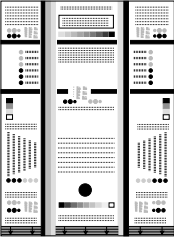
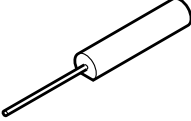
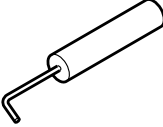
No.	Tool name	Tool No.	Appearance	Rank	Uses/remarks
1	Digital multimeter	FY9-2002		A	For making electrical checks.
2	Door switch	TKN-0093		A	
3	NA-3 Test Sheet	FY9-9196		A	For making image adjustments/checks.
4	Meter extension pin	FY9-3038		A	For making electrical checks.
5	Meter extension pin (L-shaped)	FY9-3039		A	For making electrical checks.

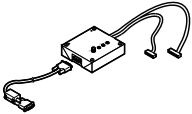
No.	Tool name	Tool No.	Appearance	Rank	Uses/remarks
6	Downloader PCB	FY9-2034		C	For Finisher-J1.

Ranking:

A : Each service person is expected to carry one.

B : Each group of about 5 service persons is expected to carry one.

C : Each workshop is expected to carry one.

G Solvents and Oils

No.	Name	Uses	Composition	Remarks
1	Alcohol	Cleaning: e.g., glass, plastic, rubber; external cover.	Alcohol, Surface activating agent, Water	Do to bring near fire. Procure locally. IPA (isopropyl alcohol) may be substituted.
2	Solvent	Cleaning: e.g., metal; oil, toner.	Fluorine-family hydrocarbon, Chlorine-family hydrocarbon, Alcohol	Do not bring near fire. Procure locally. MEK
3	Lubricant		Mineral oil (paraffin-family)	Tool No.: CK-0524 (100 cc)
4	Lubricant	Drive parts, friction parts; carriage rail.	Silicone oil	Tool No.: CK-0551 (20 g)

Prepared by
Office Imaging Products Technical Support Division
Office Imaging Products Quality Assurance Center
CANON INC.
Printed in Japan

REVISION 0 (SEPT. 2001) (30359/29685)

5-1, Hakusan 7-chome, Toride-shi, Ibaraki 302-8501 Japan



This publication is printed on
100% reprocessed paper.

Canon